

IF IT IS FOUND DESIRABLE TO CHANGE ANY TOLERANCE OR OTHER DETAIL SPECIFIED ON THIS DRAWING NOTIFY THE PURCHASER PROMPTLY.

PM-136

MAXIMUM ALLOWABLE TOLERANCES HAVE BEEN DETERMINED AND DEVIATIONS WILL BE CAUSE FOR REJECTION. REMOVE ALL BURRS AND SHARP EDGES

TWR-115

USED ON

MODEL

PROJECT NO.

ASS'Y. NO.

DATE

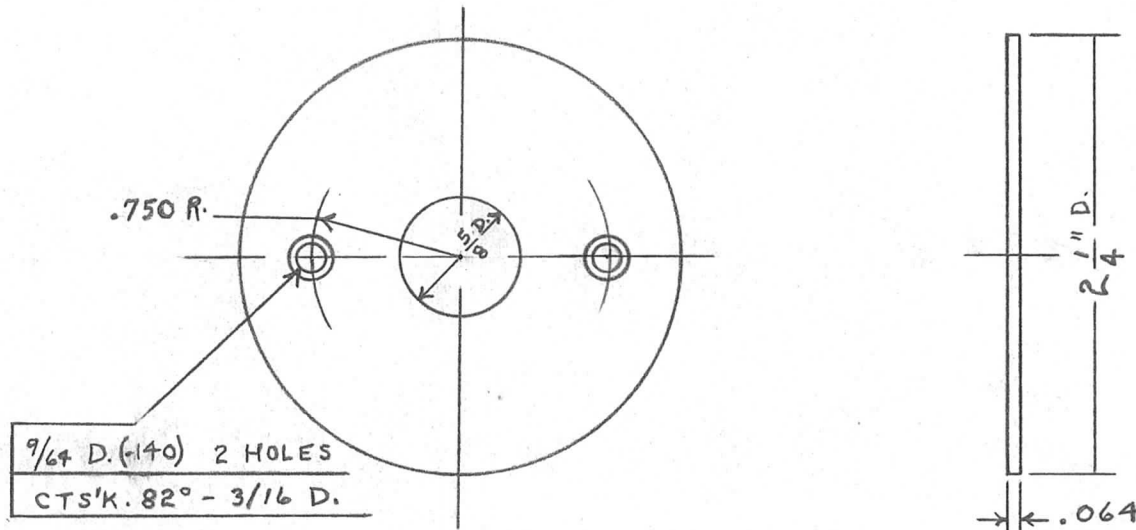

NOTE:

1. S-101 (CAUSTIC DIP)
2. S-151 (GREY WRINKLE PAINT)

REQ.	ITEM	PART NO.	DESCRIPTION	SYMBOL
		.064	TMC (Canada) LIMITED OTTAWA ONTARIO	
		STOCK SIZE		
	ALUMINUM	—H—	PLATE SPACER	
	MATERIAL	WEIGHT PER PC.	TAPE WINDING	
	52S-H32		DA 5/5/55	
	TYPE & TEMPER		DRAWN	ELEC. DES. APP. MECH. DES. APP.
	—H—			
	HEAT TREAT. SPEC.		<i>Law</i>	
	SEE NOTE		CHECKED	FINAL APPROVAL
	FINISH & SPEC. NO.			PM-136

ISSUE	ITEM	CHANGED FROM	DATE	CN. NO.	DRAFTS	CHECKER	ENG. APP.
TOLERANCES		SCALE FULL SIZE					
ALL OTHERS	DEC. DIM. ± .005	DRILL, PUNCH, COMMERCIAL STOCK SIZES AND MANUFACTURERS TOLERANCES ARE NOT INCLUDED.					
	FRAC. DIM. ± 1/64						
	ANGULAR DIM. ±						

IF IT IS FOUND DESIRABLE TO CHANGE ANY TOLERANCE OR OTHER DETAIL SPECIFIED ON THIS DRAWING NOTIFY THE PURCHASER PROMPTLY.

RELEASED

PM-136

MAXIMUM ALLOWABLE TOLERANCES HAVE BEEN DETERMINED AND DEVIATIONS WILL BE CAUSE FOR REJECTION. REMOVE ALL BURRS AND SHARP EDGES

USED ON

MODEL	PROJECT NO.	ASS'Y. NO.	DATE
TWR-115	151	A-221	9-13-52

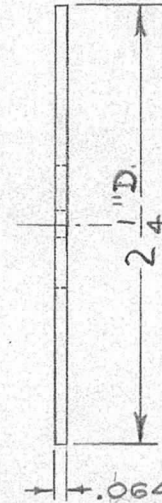
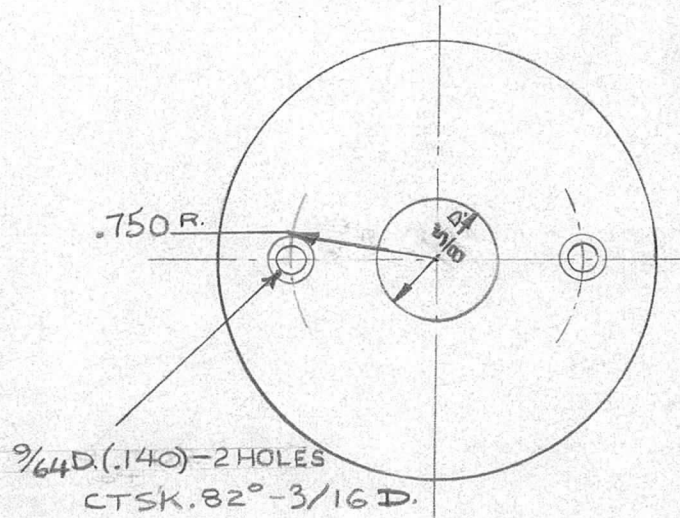

NOTE:

1. S-101 (CAUSTIC DIP)
2. S-151 (GREY WRINKLE PAINT)

REQ.	ITEM	PART NO.	DESCRIPTION	SYMBOL
		.064	THE TECHNICAL MATERIEL CORP. MAMARONECK, NEW YORK	
		STOCK SIZE		
	ALUMINUM	—ff—	PLATE SPACER	
	MATERIAL	WEIGHT PER PC.		
		525-H32		
		TYPE & TEMPER		
		—ff—		
		HEAT TREAT. SPEC.		
		SEE NOTE		
		FINISH & SPEC. NO.		

ISSUE	ITEM	CHANGED FROM	DATE	CN. NO.	DRAFTS	CHECKER	ENG. APP.

TOLERANCES		SCALE FULL SIZE
ALL OTHERS	DEC. DIM. ± .005 FRAC. DIM. ± 1/64 ANGULAR DIM. ±	DRILL, PUNCH, COMMERCIAL STOCK SIZES AND MANUFACTURERS TOLERANCES ARE NOT INCLUDED.

DRAWN	ELEC. DES. APP.	MECH. DES. APP.
<i>L. Label</i>		<i>PM</i>
<i>JAR 11/6/52</i>		<i>R</i>
CHECKED	FINAL APPROVAL	
	PM-136	