

IF IT IS FOUND DESIRABLE TO CHANGE ANY TOLERANCE OR OTHER DETAIL SPECIFIED ON THIS DRAWING NOTIFY THE PURCHASER PROMPTLY.

PM-124 A

MAXIMUM ALLOWABLE TOLERANCES HAVE BEEN DETERMINED AND DEVIATIONS WILL BE CAUSE FOR REJECTION. REMOVE ALL BURRS AND SHARP EDGES

USED ON

MODEL	PROJECT NO.	ASS'Y. NO.	DATE
XTR	116		9-22-52

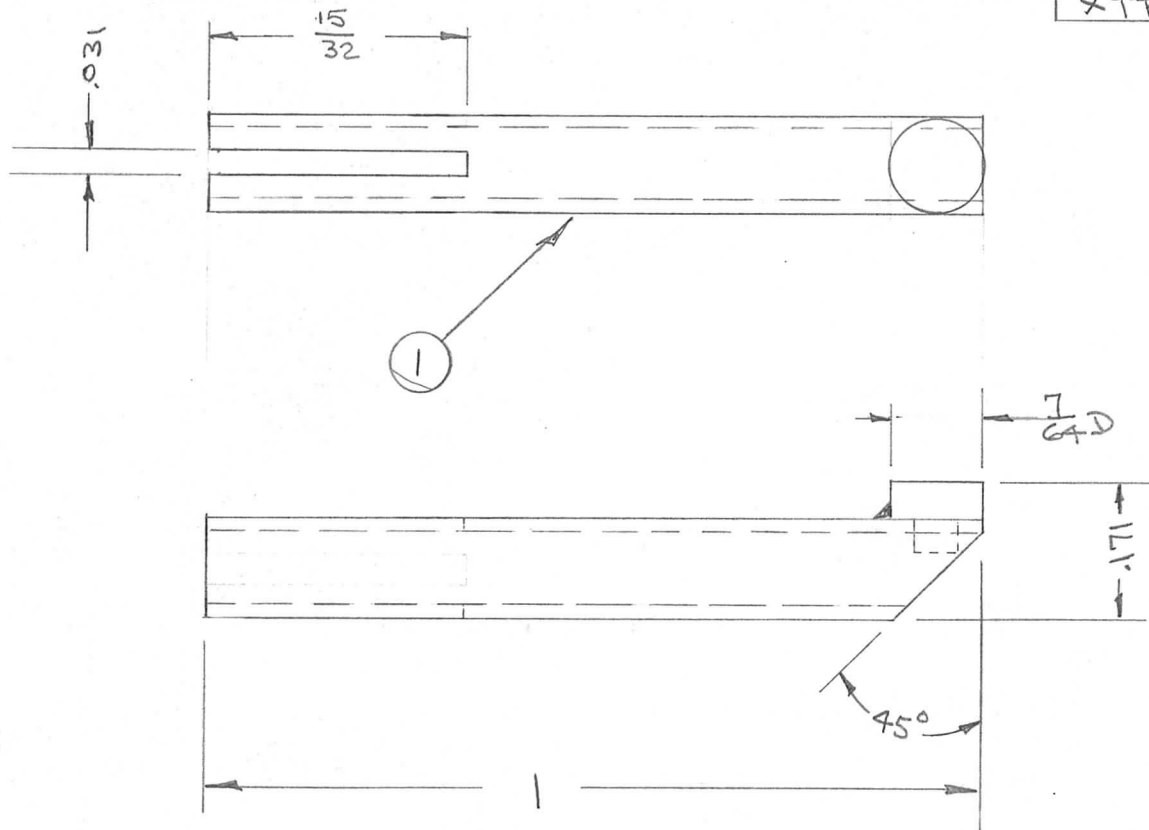

Smooth Surface on Top of Contact

Head Solder

ITEM (1) 1/8 O.D. x .097 I.D. Brass Tubing, Hard Drawn
 ITEM (2) 7/64 Brass

REQ.	ITEM	PART NO.	DESCRIPTION	SYMBOL
		SEE NOTE	THE TECHNICAL MATERIAL CORP. MAMARONECK, NEW YORK	
		STOCK SIZE		
		SEE NOTE	ARM CONTACT	
		MATERIAL WEIGHT PER PC.		
		SEE NOTE		
		TYPE & TEMPER		
		HEAT TREAT. SPEC.		
		5-135 .0005		
		Brass Nickel Plate		
		FINISH & SPEC. NO.		

ISSUE	ITEM	CHANGED FROM	DATE	CN. NO.	DRAFTS	CHECKER	ENG. APP.
A	1	VIEW ADDED	6/26/53	1	HAD	WOC	PPB
TOLERANCES		SCALE 4 X					
ALL OTHERS	DEC. DIM. ± .005	DRILL, PUNCH, COMMERCIAL STOCK SIZES AND MANUFACTURERS TOLERANCES ARE NOT INCLUDED.					
	FRAC. DIM. ± 1/64						
	ANGULAR DIM. ± 10°						

DRAWN	ELEC. DES. APP.	MECH. DES. APP.
HAD		
WOC		
CHECKED	FINAL APPROVAL	
	PPB	
	PM-124	A