

IF IT IS FOUND DESIRABLE TO CHANGE ANY TOLERANCE OR OTHER DETAIL SPECIFIED ON THIS DRAWING NOTIFY THE PURCHASER PROMPTLY.

MAXIMUM ALLOWABLE TOLERANCES HAVE BEEN DETERMINED AND DEVIATIONS WILL BE CAUSE FOR REJECTION. REMOVE ALL BURRS AND SHARP EDGES

PM-123

SECTION "A-A"
 NO. OF TEETH ON GEAR = 12
 PITCH = 48
 PITCH DIA. = .250
 PRESSURE ANGLE = 14 1/2°

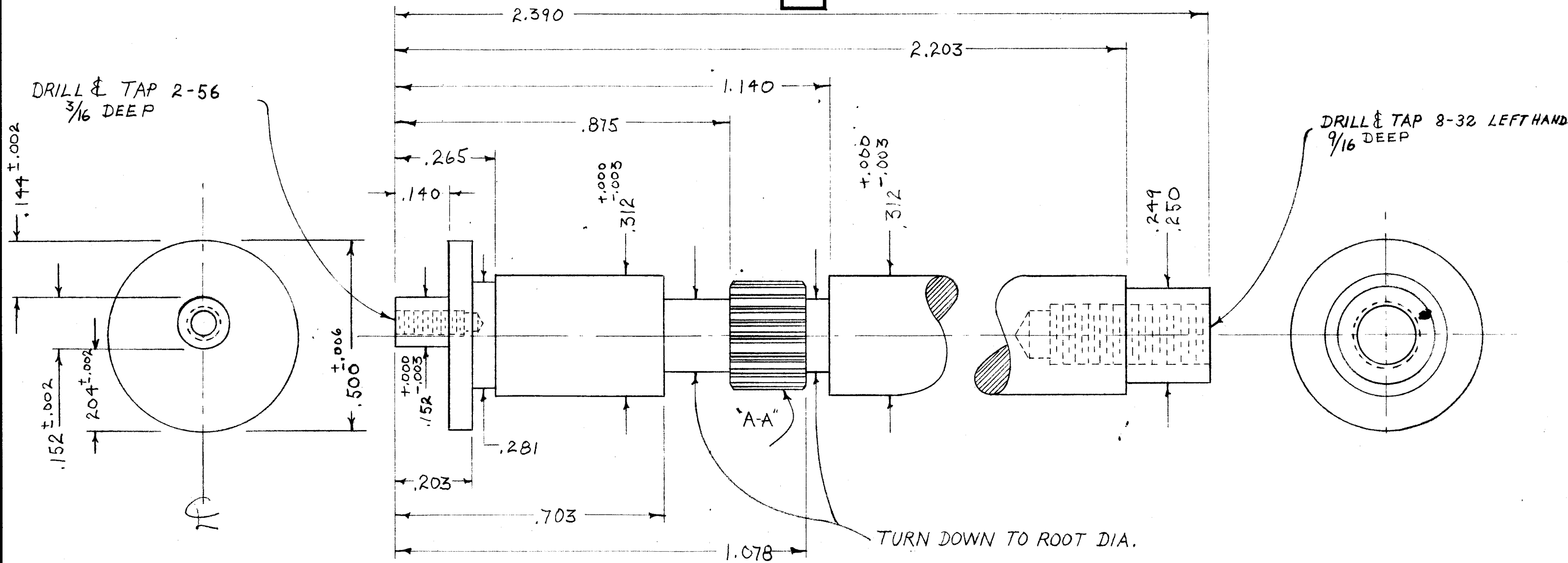

REQ.	ITEM	PART NO.	DESCRIPTION	SYMBOL
		.500	THE TECHNICAL MATERIEL CORP.	
		STOCK SIZE	MAMARONECK. NEW YORK	
		STEEL	ECCENTRIC	
		MATERIAL		
		LOW CARBON		
		TYPE & TEMPER		
		HEAT TREAT. SPEC.		
		BLACK OXIDE		
		FINISH & SPEC. NO.		

ISSUE	ITEM	CHANGED FROM	DATE	CN. NO.	DRAFTS	CHECKER	ENG. APP.
TOLERANCES							
SCALE: 4" - 1"							
DRILL, PUNCH, COMMERCIAL STOCK SIZES AND MANUFACTURERS TOLERANCES ARE NOT INCLUDED.							

XTR	116		9-6-52
MODEL	PROJECT NO.	ASS'Y. NO.	DATE

WDC 9-6-52		
DRAWN	ELEC. DES. APP.	MECH. DES. APP.
CHECKED	FINAL APPROVAL	
	PM-123	