

PM 1087

| REVISIONS |                                 | DATE     | E.M.N. NO. | DRAFT              | CHKD | APPD |
|-----------|---------------------------------|----------|------------|--------------------|------|------|
| X         | EXPER. RELEASE                  | 10-14-64 | X          | <i>[Signature]</i> |      |      |
| Ø         | ORIGINAL RELEASE FOR PRODUCTION | 11-25-64 | Ø          | <i>[Signature]</i> |      |      |

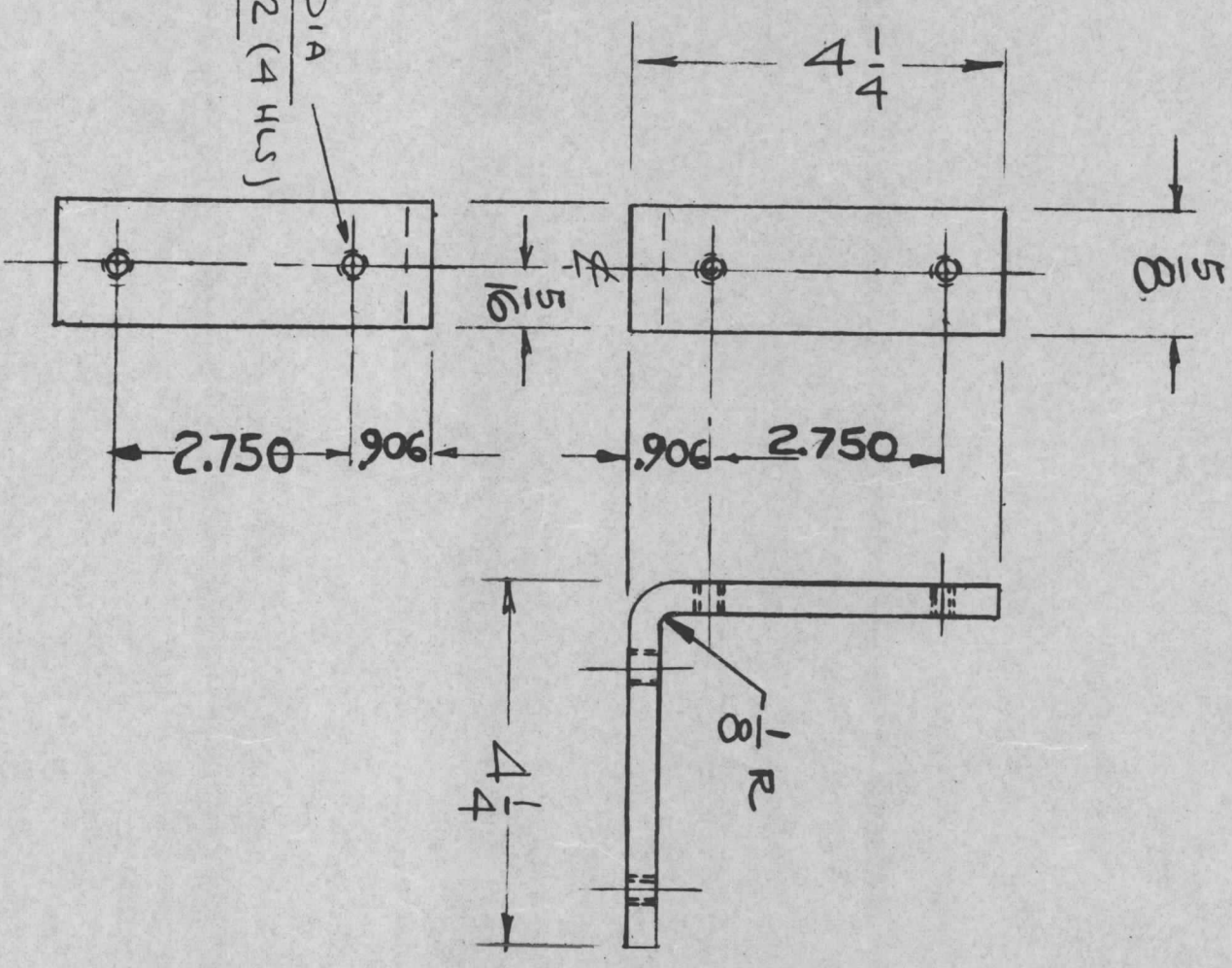

|           |   |               |        |
|-----------|---|---------------|--------|
| QTY./UNIT | 4 | RAK 102-2     | A 3716 |
| SCALE     |   | MODEL USED ON | CODE   |
|           |   | A             |        |
| ASBY. NO. |   |               |        |

| REQD. ITEM                   | PART NUMBER | DESCRIPTION        | SYMBOL    |
|------------------------------|-------------|--------------------|-----------|
| STURMER                      |             | LIST OF MATERIAL   |           |
| MATERIAL                     |             |                    |           |
| 5/16 x 5/8 H.R.S.            |             |                    |           |
| FINISH                       |             |                    |           |
| CADMIUM PLATE                |             |                    |           |
| TITLE                        |             |                    |           |
| WINDOW FRAME ANGLE           |             |                    |           |
| THE TECHNICAL MATERIEL CORP. |             |                    |           |
| MAMARONECK, NEW YORK         |             |                    |           |
| DRAWN                        | DATE        | FINAL APPROVAL     | DATE      |
| <i>[Signature]</i>           | 11-25-64    | <i>[Signature]</i> |           |
| CHECKED                      | DATE        |                    |           |
| <i>[Signature]</i>           | 11-25-64    |                    |           |
| ELECT. DES.                  | DATE        |                    |           |
| <i>[Signature]</i>           |             |                    |           |
| MECH. DES.                   | DATE        |                    |           |
| <i>[Signature]</i>           | 11-25-64    |                    |           |
| SHEET                        |             |                    | REV. LTR. |
| PM 1087                      |             |                    | Ø         |

NOTES

THE CONTENTS OF THIS DRAWING ARE THE EXCLUSIVE PROPERTY OF THE TECHNICAL MATERIEL CORP. ITS UNAUTHORIZED USE OR REPRODUCTION IN WHOLE OR IN PART IS STRICTLY FORBIDDEN.