

STANDARD DRAWING

REQ. PER UNIT

MODEL
STANDARD

USED ON
ASS'Y. NO.

DATE
4-14-64

PM-1049

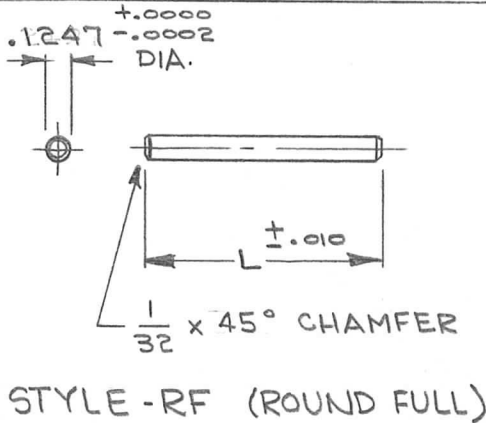

NOTE:
ALL SHAFTS SHALL NOT DEVIATE FROM STRAIGHTNESS MORE THAN .005 PER. FOOT.

TYPE DESIGNATION TO BE IN THE FOLLOWING FORM:

PM-1049-RF-1.875

BASIC TMC PART NO.

STYLE

LENGTH DESIRED EXPRESSED IN 3 DECIMAL PLACES

REQ.	ITEM	PART NO.	CAMARDA	DESCRIPTION	SYMBOL	
				THE TECHNICAL MATERIEL CORP. MAMARONECK. NEW YORK		
0	ORIGINAL RELEASE FOR PRODUCTION	4-15-64 2	<i>[Signature]</i>	STAINLESS STEEL	SHAFT, PRECISION	
X	EXPER. RELEASE	4-14-64 1	<i>[Signature]</i> @		.1247 DIA.	
SYM	DESCRIPTION	DATE	CH. NO.	DRAFTS	CHECKER	ENG. APP.
UNLESS OTHERWISE SPECIFIED DIMENSIONS ARE IN INCHES AND INCLUDE CHEMICALLY APPLIED OR PLATED FINISHES		SCALE				
DECIMALS .X ± .05 .XX ± .01 .XXX ± .005	TOLERANCES	FRACTIONS ± 1/64 ANGLES ± 0° 30'	CODE A			
				303		<i>[Signature]</i> @ 4-14-64
				5-104 PASSIVATE		<i>[Signature]</i> @ 4-15-64
				FINISH & SPEC. NO.	ELEC. DES. APP.	MECH. DES. APP.
						PM-1049