

REQ. PER UNIT	USED ON			PM-1022	Ø
	MODEL	ASS'Y. NO.	DATE		
2	LPP-4		10-21-63		

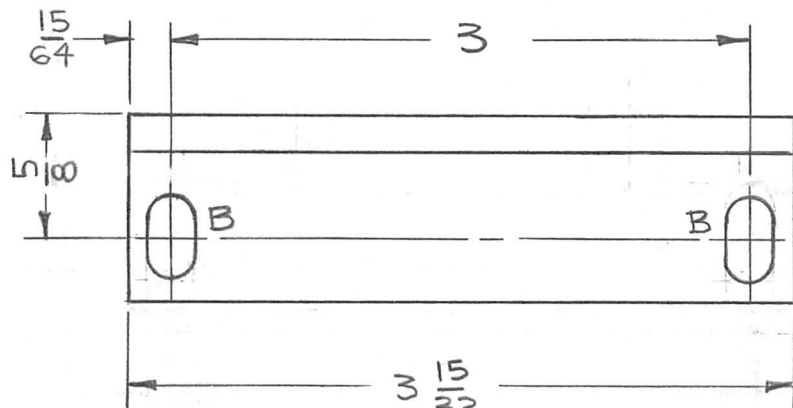

HOLE	DESCRIPTION	REQD
A	11/64 DIA	4
B	1/4 x 7/16 SLOT	2

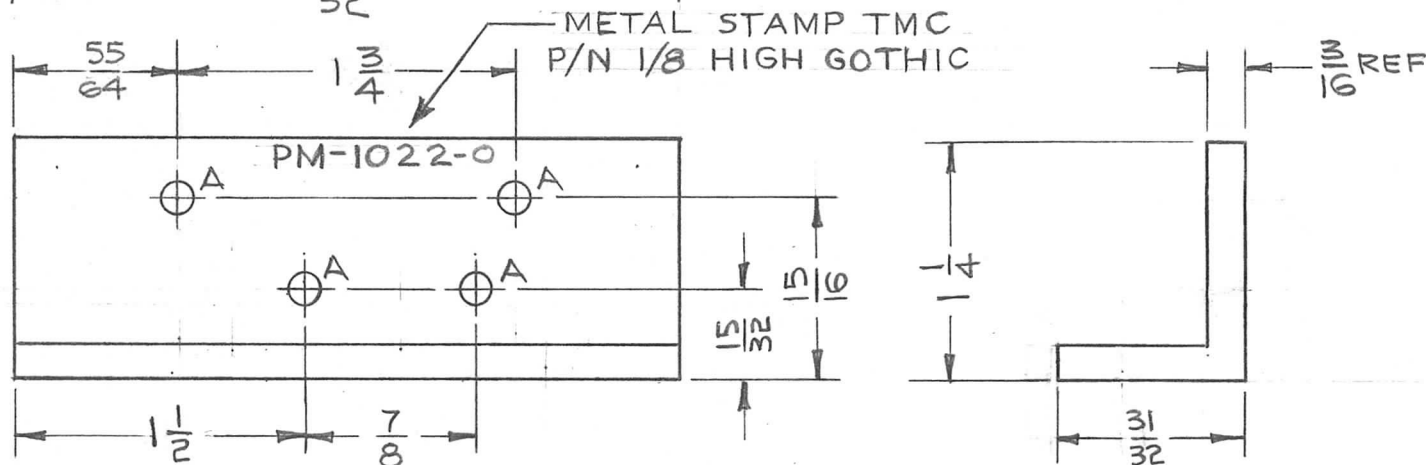

NOTE:

FINISH: ZINC CHROMATE PRIMER PER TMC S-114 &
SMOOTH GREY ENAMEL PER TMC S-115

REMOVE ALL BURRS & SHARP EDGES

REF: LD-1430, LD-1431

SYM	DESCRIPTION	DATE	CH. NO.	DRAFTS	CHECKER	ENG. APP.	REQ. ITEM	PART NO.	I. JOHNSON	DESCRIPTION	SYMBOL	
Ø	ORIGINAL RELEASE FOR PRODUCTION	3/9/64	2				1/4 x 1/4 x 3/16 THK			THE TECHNICAL MATERIEL CORP. MAMARONECK, NEW YORK	SUPPORT, FRONT, PANEL	
X	EXPER. RELEASE	3/9/64	1				ALCOA DIE NO. 79-P EXTR ALUMINUM					
UNLESS OTHERWISE SPECIFIED DIMENSIONS ARE IN INCHES AND INCLUDE CHEMICALLY APPLIED OR PLATED FINISHES							MATERIAL					
SCALE 1:1							6063-T5					
DECIMALS .X ± .05 .XX ± .01 .XXX ± .005							TYPE & TEMPER		HEAT TREAT. SPEC.	DRAWN	CHECKED	FINAL APPROVAL
FRACTIONS ± 1/64 ANGLES ± 0° 30'							SEE NOTE					
TOLERANCES							FINISH & SPEC. NO.		ELEC. DES. APP.	MECH. DES. APP.		
CODE A											PM-1022	Ø