

IF IT IS FOUND DESIRABLE TO CHANGE ANY TOLERANCE OR OTHER DETAIL SPECIFIED ON THIS DRAWING NOTIFY THE PURCHASER PROMPTLY.

MAXIMUM ALLOWABLE TOLERANCES HAVE BEEN DETERMINED AND DEVIATIONS WILL BE CAUSE FOR REJECTION. REMOVE ALL BURRS AND SHARP EDGES

RELEASED

PM-127  
A

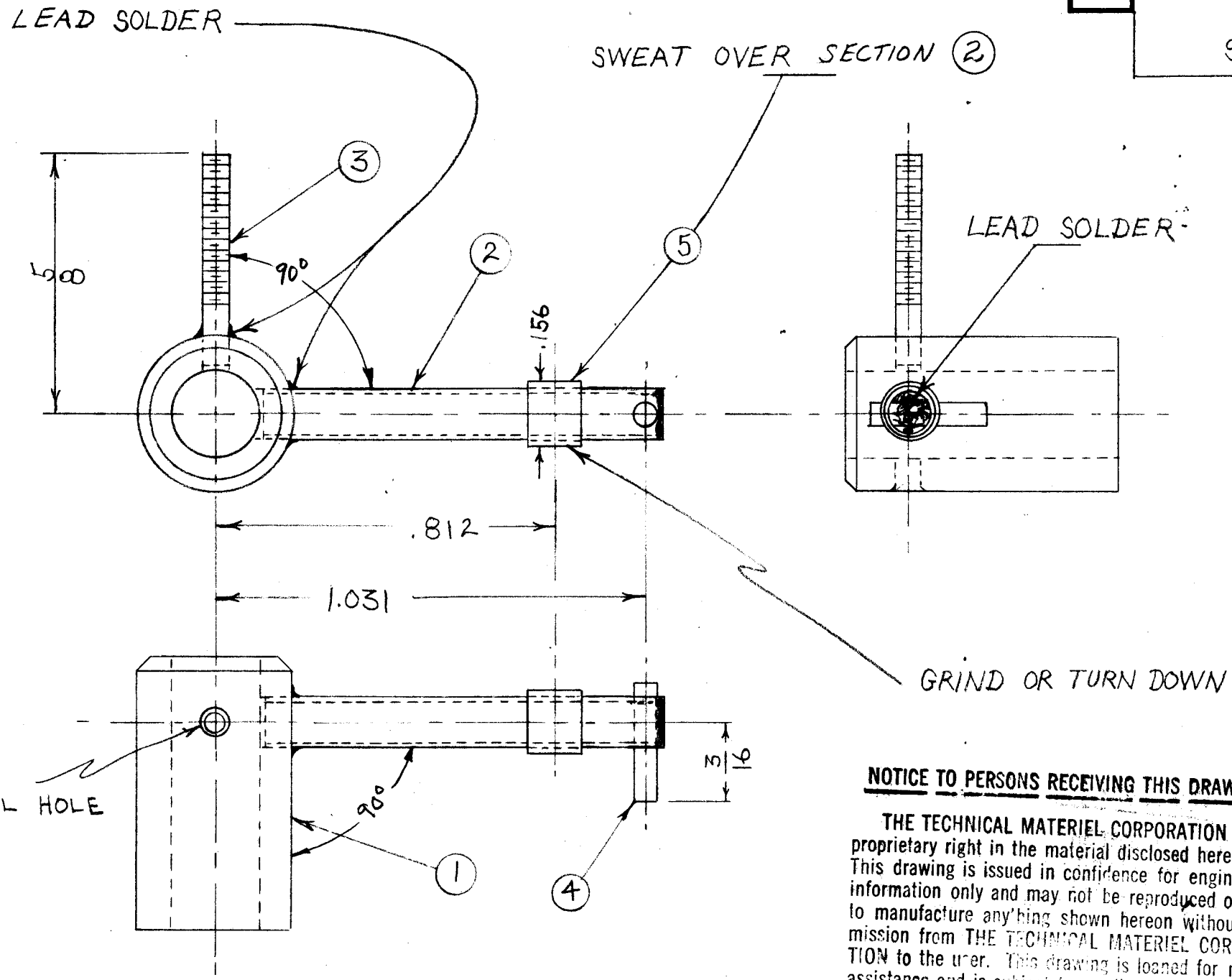
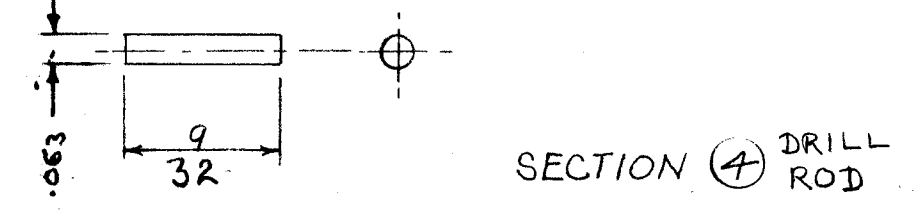
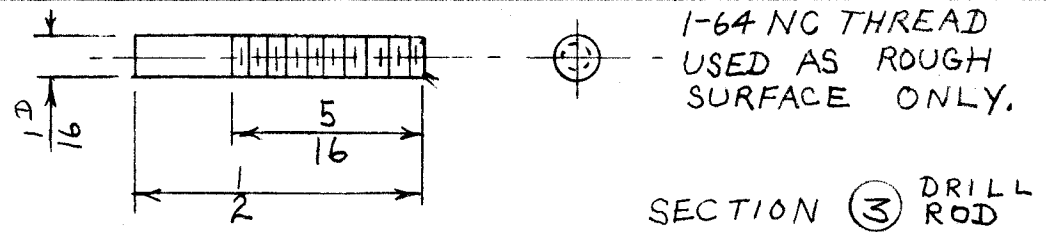
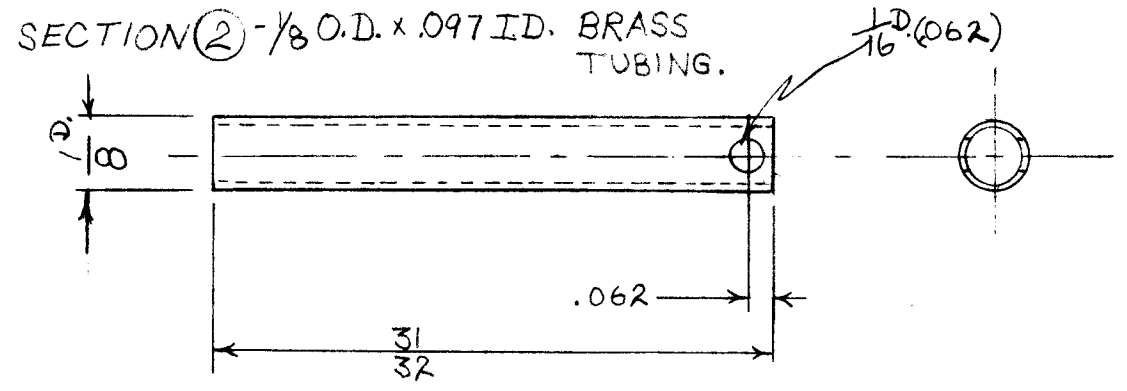
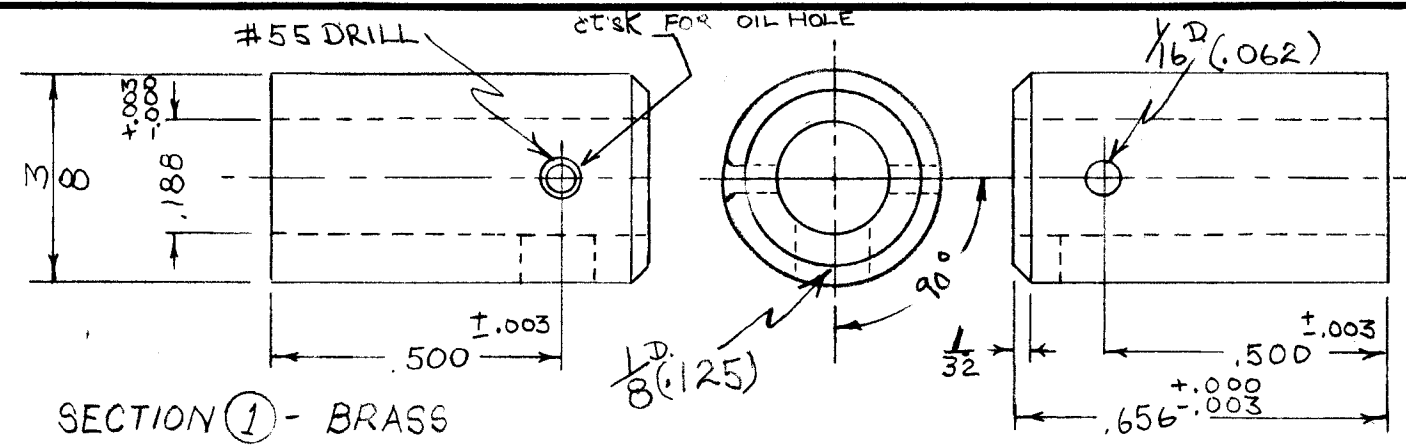

**NOTICE TO PERSONS RECEIVING THIS DRAWING**

THE TECHNICAL MATERIEL CORPORATION claims proprietary right in the material disclosed hereon. This drawing is issued in confidence for engineering information only and may not be reproduced or used to manufacture anything shown hereon without permission from THE TECHNICAL MATERIEL CORPORATION to the user. This drawing is loaned for mutual assistance and is subject to recall at any time.

Property of:  
THE TECHNICAL MATERIEL CORPORATION  
MAMARONECK, NEW YORK

REQ.	ITEM	PART NO.	DESCRIPTION	SYMBOL
	#		THE TECHNICAL MATERIEL CORP.	
		STOCK SIZE	MAMARONECK. NEW YORK	
	#	#	ELBOW ON	
		MATERIAL	WEIGHT PER PC.	
		#		
		TYPE & TEMPER	WDC 9/24/52	PPB
		#	DRAWN	ELEC. DES. APP. MECH. DES. APP.
		HEAT TREAT. SPEC.	PPB	
		FINISH & SPEC. NO.	CHECKED	FINAL APPROVAL
		S-105 CAD. PLATE .0005		

ISSUE	ITEM	CHANGED FROM	DATE	CN. NO.	DRAFTS	CHECKER	ENG. APP.
A	1	Added	6/24/53	1	ADD	WDC	PPB

TOLERANCES: DEC. DIM. ± .005, FRAC. DIM. ± 1/64, ANGULAR DIM. ±

SCALE: 3X

DRILL, PUNCH, COMMERCIAL STOCK SIZES AND MANUFACTURERS TOLERANCES ARE NOT INCLUDED.

XTR	116		9-24-52
MODEL	PROJECT NO.	ASS'Y. NO.	DATE

PM-127 A