

IF IT IS FOUND DESIRABLE TO CHANGE ANY TOLERANCE OR OTHER DETAIL SPECIFIED ON THIS DRAWING NOTIFY THE PURCHASER PROMPTLY.

STANDARD DRAWING

PL-274 B
(UG-363/U)

MAXIMUM ALLOWABLE TOLERANCES HAVE BEEN DETERMINED AND DEVIATIONS WILL BE CAUSE FOR REJECTION.
REMOVE ALL BURRS AND SHARP EDGES

USED ON

MODEL

PROJECT NO.

ASS'Y. NO.

DATE

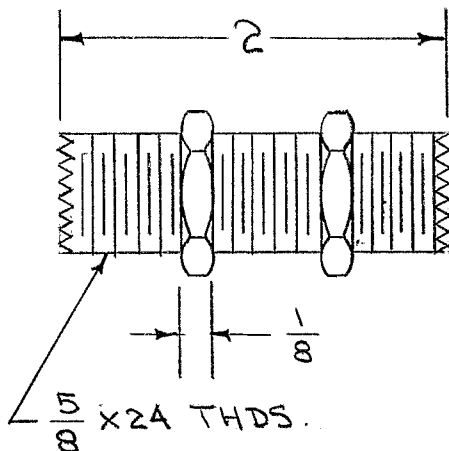

DOUBLE END BRONZE SLEEVE CONTACT.
BRASS SHELL. SLEEVE & SHELL
SILVER PLATED.
POLYSTYRENE INSERT
NUTS ARE ALUMINUM.

NOTE - PL-274 & UG-363/U
ARE IDENTICAL. USE
EITHER NUMBER

REF: AMERICAN PHENOLIC CORP. No. 83-1F

REQ.	ITEM	PART NO.	DESCRIPTION			SYMBOL
		#	THE TECHNICAL MATERIEL CORP.			
		STOCK SIZE	MAMARONECK, NEW YORK			
		#	#	ADAPTER, BULK HEAD		
		MATERIAL	WEIGHT PER PC.			
B	1	INSERT WAS TEFLON	6/11/6	2	QJP	A.J.J.
A	1	INSERT WAS POLYSTYRENE	9/1/54	1	C.D.D.	A.J.J.
ISSUE	ITEM	CHANGED FROM	DATE	CN. NO.	DRAFTS CHECKER	ENG. APP.
TOLERANCES			SCALE #			
ALL OTHERS	DEC. DIM. ± FRAC. DIM. ± ANGULAR DIM. ±		DRILL, PUNCH, COMMERCIAL STOCK SIZES AND MANUFACTURERS TOLERANCES ARE NOT INCLUDED.			
		TYPE & TEMPER	C.D.D. G-30-54		QJP	WJL
		HEAT TREAT. SPEC.	DRAWN		QJP	A.J.J.
		FINISH & SPEC. NO.	CHECKED		FINAL APPROVAL	
					PL-274 B (UG-363/U)	