

STANDARD DRAWING

TMC PART NO.	MFG# P/N	C'SK & TH'D
NT155-0832	A1006-0832	8-32
NT155-1032	A1006-1032	10-32
NT155-2520	A1006-2520	1/4-20
NT155-3118	A1007	5/16-18

REQ. PER UNIT	USED ON		
	MODEL	ASS'Y. NO.	DATE
	TST() 2.5K		4-18-66
	ATLA-2.5		

NT155	Ø
-------	---

SPRING PEENED TO NUT

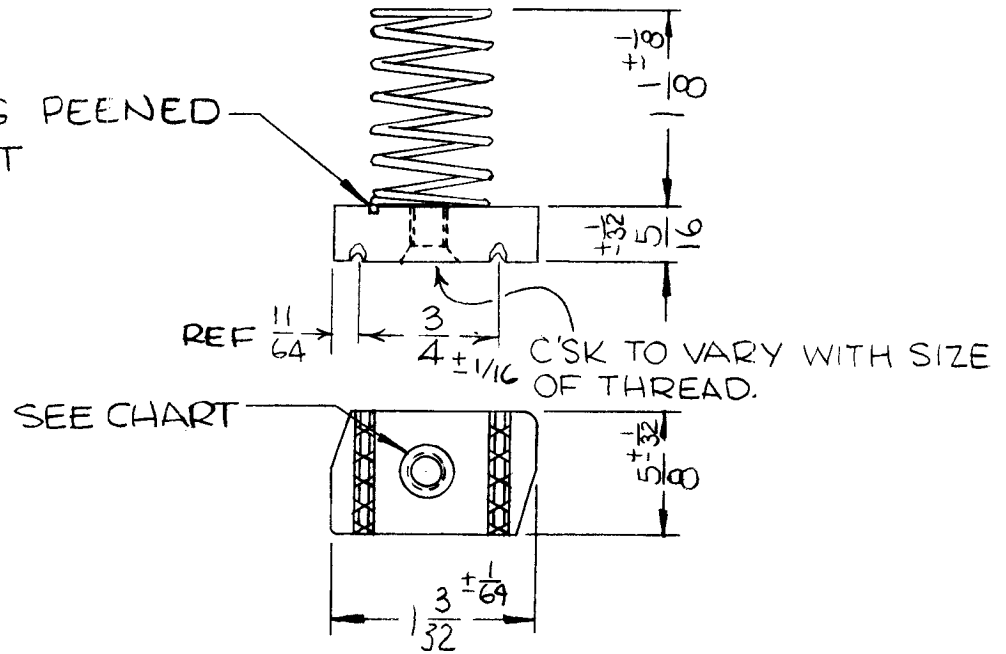

MATERIEL :
 NUT - H.B. STEEL
 SPRING - SAE-1060
 HARD DRAWN SPRING
 STEEL WIRE GALV.

REQ.	ITEM	PART NO.	BUDETTI	DESCRIPTION	SYMBOL												
		SEE NOTE	THE TECHNICAL MATERIEL CORP. MAMARONECK. NEW YORK														
		STOCK SIZE	NUT, SPRING														
Ø		ORIGINAL RELEASE FOR PRODUCTION	5/12/66	Jc	<i>[Signature]</i>												
SYM	DESCRIPTION		DATE	CH. NO.	DRAFTS	CHECKER	ENG. APP.	MATERIAL									
UNLESS OTHERWISE SPECIFIED DIMENSIONS ARE IN INCHES AND INCLUDE CHEMICALLY APPLIED OR PLATED FINISHES			SCALE		S401-429												
DECIMALS .X ± .05 .XX ± .01 .XXX ± .005		FRACTIONS ± 1/64 ANGLES ± 0° 30'		TOLERANCES		CODE		TYPE & TEMPER		HEAT TREAT. SPEC.		DRAWN		CHECKED		FINAL APPROVAL	
												<i>[Signature]</i>		<i>[Signature]</i>			
												NT155		Ø			