

REQ. PER UNIT	USED ON		
	MODEL	ASSY. NO.	DATE
			4-10-61

NT-134

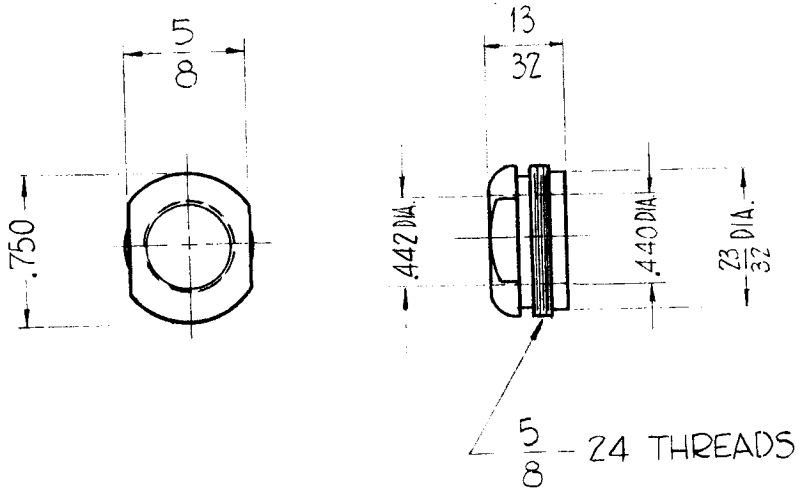

SPECIFICATIONS

MATERIAL -  
BRASS

FINISH -  
SILVER PLATED AND RHODIUM FLASHED.

REF: FOR USE W/ RG-8/U + RG-11/U,  
MATES W/ QDS CONNECTORS

								REQ.	ITEM	PART NO.	DESCRIPTION	SYMBOL				
											THE TECHNICAL MATERIEL CORP.					
											MAMARONECK, NEW YORK					
											NUT, ADAPTOR					
											CABLE TO CONNECTOR					
ISSUE	ITEM	CHANGED FROM	DATE	CH. NO.	DRAFTS	CHECKER	ENG. APP.				John C. Biele					
TOLERANCES			SCALE: S-401-70-(573-12)													
DEC. DIM. ±			MAXIMUM ALLOWABLE TOLERANCES HAVE BEEN DETERMINED AND ANY DEVIATIONS WILL BE CAUSE FOR REJECTION. REMOVE ALL BURRS AND SHARP EDGES													
FRAC. DIM. ± 1/64																
ANGULAR DIM. ±																
								TYPE & TEMPER	HEAT TREAT. SPEC.		DRAWN	CHECKED	FINAL APPROVAL			
								FINISH & SPEC. NO.			ELEC. DES. APP	MECH. DES. APP	NT-134			