

REQ. PER UNIT	USED ON			NP666	Ø
	MODEL	ASS'Y. NO.	DATE		
1	HFRR-2		8-21-64		

FINISH: REVERSE ETCH ANODIZE ON LUSTER-LESS BLACK BACKGROUND (TYPE 37038) PER FED-STD-595.  
 COLORLESS VARNISH PER MIL-V-6894.

MIN. LETTER SIZE-3/64" HIGH

ORDER AND SERIAL NUMBERS TO BE STEEL STAMPED BY TMC.

NAMEPLATE TO BE IN ACCORDANCE WITH MIL STD-130 AND MIL-M-13231 AND AMENDS.

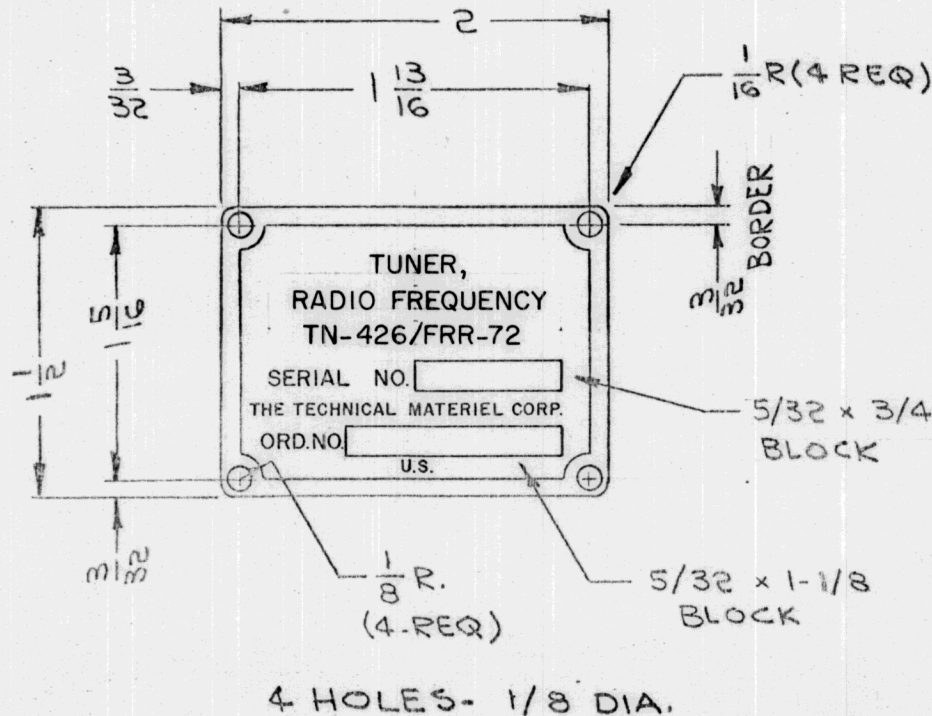

4 HOLES- 1/8 DIA.

REQ. ITEM	PART NO.	DESCRIPTION	SYMBOL
Ø	.032 THK	THE TECHNICAL MATERIEL CORP. MAMARONECK. NEW YORK	
X	ALUMINUM	NAMEPLATE, IDENTIFICATION	
SYM	DESCRIPTION	DATE	CH. NO. DRAFTS CHECKER ENG. APP.
UNLESS OTHERWISE SPECIFIED DIMENSIONS ARE IN INCHES AND INCLUDE CHEMICALLY APPLIED OR PLATED FINISHES		SCALE	1:1
DECIMALS X ± .05 XX ± .01 XXX ± .005	TOLERANCES	FRACTIONS ± 1/64 ANGLES ± 0° 30'	CODE A
	5052-H32	—	Q. Swan
	TYPE & TEMPER	HEAT TREAT. SPEC.	DRAWN CHECKED FINAL APPROVAL
	SEE NOTE		
	FINISH & SPEC. NO.	ELEC. DES. APP. MECH. DES. APP.	NP666 Ø