

NP 412

THE CONTENTS OF THIS DRAWING ARE THE EXCLUSIVE PROPERTY OF THE TECHNICAL MATERIEL CORP. ITS UNAUTHORIZED USE OR REPRODUCTION IN WHOLE OR IN PART IS STRICTLY FORBIDDEN.

REQ. PER UNIT 1	USED ON		ND-412	B
	MODEL TRC	ASS'Y. NO.		

STANDARD DRAWING

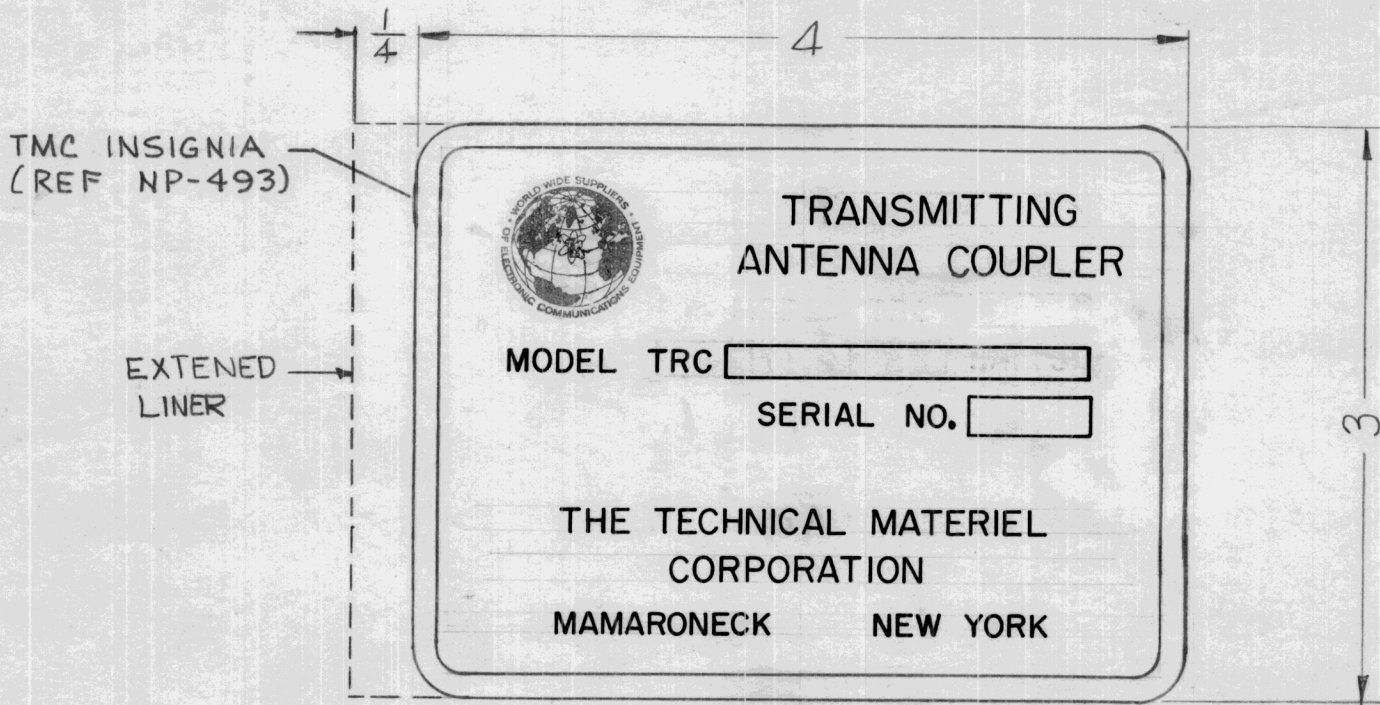

- NOTES~
- (1) THIS NAMEPLATE WILL BE MOUNTED ON AN EPOXY RESIN COVERED CASE.
 - (2) ALUMINUM COLORED GOTHIC LETTERS, APP. SIZES SHOWN.
 - (3) BACKGROUND TO BE BLACK W/ALUM. BORDER.
 - (4) TO BE SUPPLIED WITH PRESSURE SENSITIVE ADHESIVE BACKING AND 1/4 EXTENDED ZIP OF LINER TO ALLOW FOR EASY REMOVAL.

REF. ~ IN ACCORDANCE WITH MIL-P-19834

REQ.	ITEM	PART NO.				DESCRIPTION	SYMBOL	
		.003 to .005				THE TECHNICAL MATERIEL CORP. MAMARONECK, NEW YORK	NAMEPLATE, IDENTIFICATION	
		STOCK SIZE						
B	EXTENDED LINER ADDED	S-1465	14033	CJL	JL	ALUMINUM FOIL	ADHESIVE TYPE	
A	NEW TMC INSIGNIA ADDED	8-8-62	7046	MJT	JWB			
SYM	DESCRIPTION	DATE	CH. NO.	DRAFTS	CHECKER	ENG. APP.		
UNLESS OTHERWISE SPECIFIED: DIMENSIONS ARE IN INCHES TOLERANCES ON FRAC. ± 1/64 DEC. ± .005 ANGLES ± 1/2°		SCALE: <i>1/4" = 1"</i>		MAXIMUM ALLOWABLE TOLERANCES HAVE BEEN DETERMINED AND ANY DEVIATIONS WILL BE CAUSE FOR REJECTION. REMOVE ALL BURRS AND SHARP EDGES				
				ANODIZED		D.S. Man	RUZZO	
				TYPE & TEMPER		DRAWN	CHECKED	
				HEATTREAT. SPEC.		FINAL APPROVAL		
				SEE NOTE		JWB	all	
				FINISH & SPEC. NO.		ELEC. DES. APP.	MECH. DES. APP.	
						ND-412 B		

THE CONTENTS OF THIS DRAWING ARE THE EXCLUSIVE PROPERTY OF THE TECHNICAL MATERIEL CORP. ITS UNAUTHORIZED USE OR REPRODUCTION IN WHOLE OR IN PART IS STRICTLY FORBIDDEN.

REQ. PER UNIT

USED ON

MODEL

ASS'Y. NO.

DATE

1

AMC-6-3-70U

12-20-61

NP-413

B

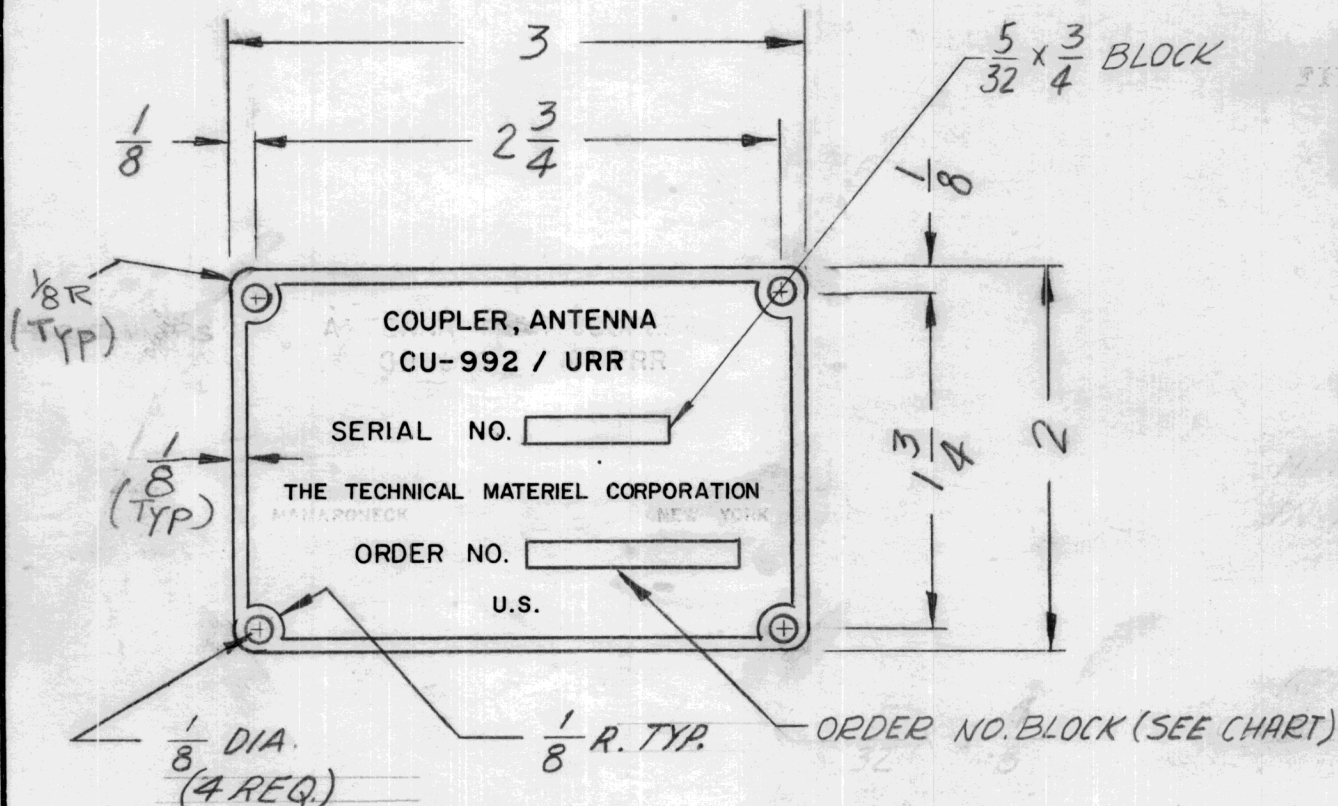

FINISH:
 REVERSE ETCH ANODIZE ON LUSTERLESS
 BLACK BACKGROUND (37038)
 PER FED. STD. NO. 595
 COLORLESS VARNISH PER MIL-V-6894

MINIMUM LETTER SIZE - 3/64 HIGH

APPLICABLE ORDER NUMBER AND SERIAL NUMBER WILL BE STEEL STAMPED BY TMC OR WHERE PURCHASING REQUIREMENT IS SUFFICIENTLY LARGE, ORDER NUMBER SHALL BE ETCHED BY VENDOR IN LIEU OF BLOCK. SEE CHART.

TMC NO.	ORDER NO. BLOCK	ORDER NO. (ETCHED BY VENDOR)
NP-413-1	5/32 x 1-1/8 BLOCK	NO ORDER NUMBER
NP-413-2	NO BLOCK	15060-PP-62

NAMEPLATE TO BE IN ACCORDANCE WITH MIL-STD-130 AND MIL-M-13231A (REF: SIGNAL CORPS)

REQ.	ITEM	PART NO.	DESCRIPTION			SYMBOL
		.032 THK.	THE TECHNICAL MATERIEL CORP.			
		STOCK SIZE	MAMARONECK, NEW YORK			
B	MAM'K, N.Y. DELETED ON PICTORIAL	7-28-64 11955	NAMEPLATE, IDENTIFICATION			
A	SPEC WAS TT 595/37038 WAS 3727/ADD. CHART DELETED ORDER NO. DIM. CU 992 / URR WAS FR	5-29-62 6696	AMC-6-3-70U			
SYM	DESCRIPTION	DATE	CH. NO.	DRAFTS	CHECKER	ENG. APP.
UNLESS OTHERWISE SPECIFIED: DIMENSIONS ARE IN INCHES TOLERANCES ON FRAC. ± 1/64 DEC. ± .005 ANGLES ± 1/2°		SCALE: MAXIMUM ALLOWABLE TOLERANCES HAVE BEEN DETERMINED AND ANY DEVIATIONS WILL BE CAUSE FOR REJECTION. REMOVE ALL BURRS AND SHARP EDGES				
		250			wh	JAM
		TYPE & TEMPER	HEATTREAT. SPEC.	DRAWN	CHECKED	FINAL APPROVAL
		SEE NOTE				NP-413 B
		FINISH & SPEC. NO.	ELEC. DES. APP.	MECH. DES. APP.		

THE CONTENTS OF THIS DRAWING ARE THE EXCLUSIVE PROPERTY OF THE TECHNICAL MATERIEL CORP. ITS UNAUTHORIZED USE OR REPRODUCTION IN WHOLE OR IN PART IS STRICTLY FORBIDDEN.

REQ. PER UNIT

USED ON

MODEL

ASS'Y. NO.

DATE

7-30-62

NP-417

C

TMC PART NO.	TITLE INSERT	MODEL INSERT
NP-417-1	VOICE FREQ. MULTIPLEXER	TMX
NP-417-2	VOICE FREQ. DEMULTIPLEXER	RMX
NP-417-3	AUDIO & DC MONITOR	520B
NP-417-4	SIGNAL DIST. UNIT	521TA
NP-417-5	POWER DIST. UNIT	522
NP-417-6	VOICE FREQ. MULTIPLEXER	TMXI
NP-417-7	VOICE FREQ. DEMULTIPLEXER	RMXI
NP-417-8	VOICE DIVERSITY SELECTOR	DVC
NP-417-9	AUDIO SPEECH INVERTER	ASI

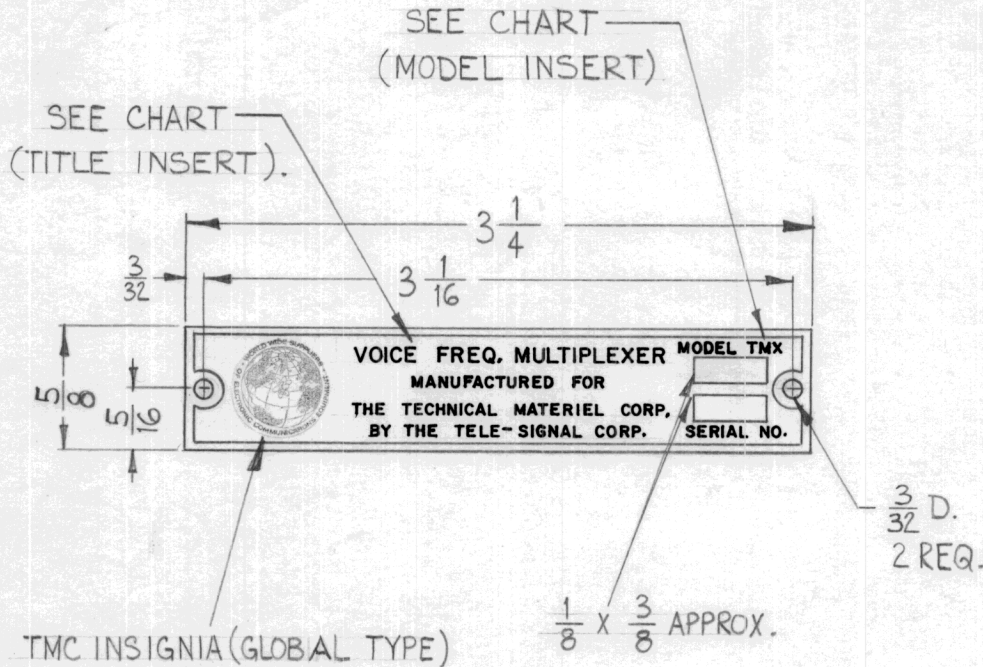

REQ.	ITEM	PART NO.	DESCRIPTION	SYMBOL
C	NP-417-9 ADDED TO CHART (-7) WAS VOICE FREQ. MULTIPLEXER	8.13.64 12133	W.B. 110?	
B	NP-417-6, 7 & 8 ADDED	7-30-63 9683	AK. 203	
A	NP-417-3, 4 & 5 ADDED, TMC INSIGNIA REVISED REDRAWN	7-30-62 6996	W.A.F. 102	
SYM	DESCRIPTION	DATE	CH. NO.	DRAFTS
UNLESS OTHERWISE SPECIFIED:		SCALE: FULL		
DIMENSIONS ARE IN INCHES		MAXIMUM ALLOWABLE TOLERANCES HAVE BEEN DETERMINED AND ANY DEVIATIONS WILL BE CAUSE FOR REJECTION.		
TOLERANCES ON		REMOVE ALL BURRS AND SHARP EDGES		
FRAC. ± 1/64 DEC. ± .005 ANGLES ± 1/2°				
		250	W.A. Franco	
		TYPE & TEMPER	HEATTREAT. SPEC.	DRAWN
		BLACK MATT BACKGROUND & CLEAR LACQUER		CHECKED
		FINISH & SPEC. NO.	ELEC. DES. APP.	MECH. DES. APP.
				FINAL APPROVAL
				NP-417
				C

THE CONTENTS OF THIS DRAWING ARE THE EXCLUSIVE PROPERTY OF THE TECHNICAL MATERIEL CORP. ITS UNAUTHORIZED USE OR REPRODUCTION IN WHOLE OR IN PART IS STRICTLY FORBIDDEN.

REQ. PER UNIT

USED ON

MODEL

ASS'Y. NO.

DATE

RAC-32

3-2-62

NP-451

B

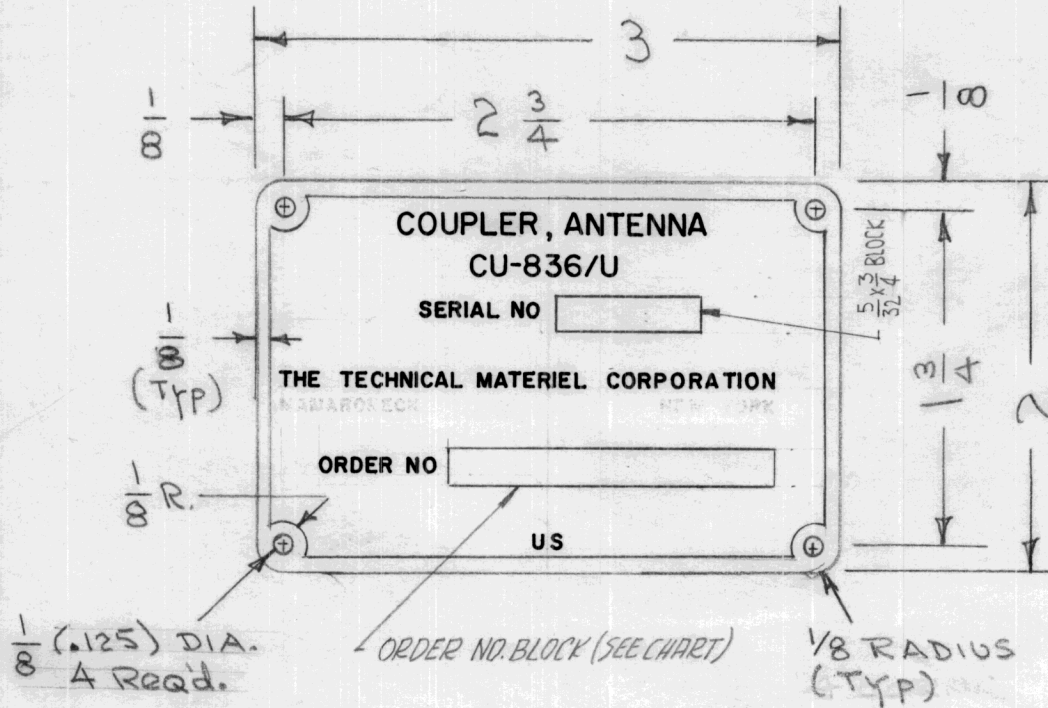

FINISH:
REVERSE ETCH ANODIZE ON LUSTERLESS
BLACK BACKGROUND (37038)
PER FED. STD. NO. 595
COLORLESS VARNISH PER MIL-V-6894

MINIMUM LETTER SIZE - 3/64 HIGH

APPLICABLE ORDER NUMBER AND SERIAL
NUMBER WILL BE STEEL STAMPED BY
TMC OR
WHERE PURCHASING REQUIREMENT IS
SUFFICIENTLY LARGE, ORDER NUMBER
SHALL BE ETCHED BY VENDOR IN LIEU
OF BLOCK. SEE CHART.

TMC PART NO.	ORDER NO. BLOCK	ORDER NO. (ETCHED BY VENDOR)
NP-451-1	5/32 x 1-1/8 BLOCK	NO ORDER NUMBER
NP-451-2	NO BLOCK	15060-PP-62

NAMEPLATE TO BE IN ACCORDANCE WITH
MIL-STD-130 AND MIL-M-13231A
(REF: SIGNAL CORPS)

REQ.	ITEM	PART NO.	DESCRIPTION	SYMBOL
			THE TECHNICAL MATERIEL CORP. MAMARONECK, NEW YORK	
B	MAM'K, N.Y DELETED ON PICTORIAL	72864 11955	ALUMINUM	IDENTIFICATION PLATE
A	CHART, BLOCK DIM. ADDED 37038 WAS 3727 SPEC WAS 595 ORDER NO. ADDED.	5-29-62 6696	250	MODEL RAC-32 (CU-836/U)
SYM	DESCRIPTION	DATE	CH. NO.	DRAFTS
UNLESS OTHERWISE SPECIFIED: DIMENSIONS ARE IN INCHES TOLERANCES ON FRAC. ± 1/64 DEC. ± .005 ANGLES ± 1/2°		SCALE: MAXIMUM ALLOWABLE TOLERANCES HAVE BEEN DETERMINED AND ANY DEVIATIONS WILL BE CAUSE FOR REJECTION. REMOVE ALL BURRS AND SHARP EDGES		
		TYPE & TEMPER	HEAT TREAT. SPEC.	DRAWN
		SEE NOTE		CHECKED
		FINISH & SPEC. NO.		FINAL APPROVAL
		ELEC. DES. APP.	MECH. DES. APP.	NP-451 B

THE CONTENTS OF THIS DRAWING ARE THE EXCLUSIVE PROPERTY OF THE TECHNICAL MATERIEL CORP. ITS UNAUTHORIZED USE OR REPRODUCTION IN WHOLE OR IN PART IS STRICTLY FORBIDDEN.

REQ. PER UNIT

USED ON

MODEL

ASS'Y. NO.

DATE

TRC-3500

3-2-62

NP-452

B

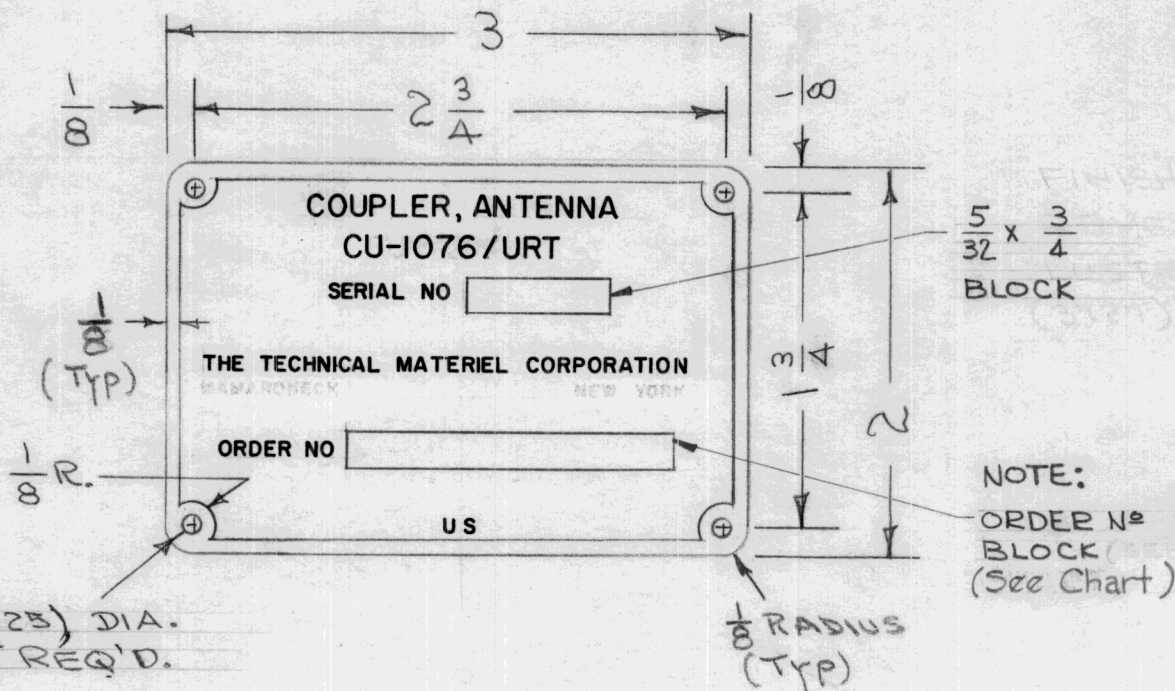

FINISH:

REVERSE ETCH ANODIZE ON LUSTERLESS BLACK BACKGROUND (37038)
PER FED. STD. NO. 595
COLORLESS VARNISH PER MIL-V-6894

MINIMUM LETTER SIZE - 3/64 HIGH

APPLICABLE ORDER NUMBER AND SERIAL NUMBER WILL BE STEEL STAMPED BY TMC OR

WHERE PURCHASING REQUIREMENT IS SUFFICIENTLY LARGE, ORDER NUMBER SHALL BE ETCHED BY VENDOR IN LIEU OF BLOCK. SEE CHART.

TMC. N ^o	ORDER N ^o BLOCK	ORDER N ^o . (ETCHED BY VENDOR)
NP-452-1	5/32 x 1-1/8 BLOCK	NO ORDER N ^o .
NP-452-2	NO BLOCK	15060-PP-62

NAMEPLATE TO BE IN ACCORDANCE WITH MIL-STD-130 AND MIL-M-13231A (REF: SIGNAL CORPS)

REQ.	ITEM	PART NO.	DESCRIPTION	SYMBOL						
			.032 THICK							
			STOCK SIZE							
B	MAM'K, N.Y. DELETED ON PICTORIAL	728-64 11955	ALUMINUM	THE TECHNICAL MATERIEL CORP. MAMARONECK, NEW YORK						
A	CHART, NOTE, & BLOCK SIZE ADDED. NOMEN. WAS CU-729; FINISH CLARIFIED	5-29-62 6769 G.S.		IDENTIFICATION PLATE						
SYM	DESCRIPTION	DATE	CH. NO.	DRAFTS	CHECKER	ENG. APP.	MATERIAL	MODEL TRC-3500 (CU-729/URT)		
UNLESS OTHERWISE SPECIFIED:		SCALE:		250		GG	FILE	SM	FILE	
DIMENSIONS ARE IN INCHES		MAXIMUM ALLOWABLE TOLERANCES HAVE BEEN DETERMINED AND ANY DEVIATIONS WILL BE CAUSE FOR REJECTION.		TYPE & TEMPER		HEATTREAT. SPEC.		DRAWN	CHECKED	FINAL APPROVAL
TOLERANCES ON		REMOVE ALL BURRS AND SHARP EDGES		SEE NOTE						NP-452 B
FRAC. ± 1/64 DEC. ± .005 ANGLES ± 1/2°				FINISH & SPEC. NO.		ELEC. DES. APP.		MECH. DES. APP.		

THE CONTENTS OF THIS DRAWING ARE THE EXCLUSIVE PROPERTY OF THE TECHNICAL MATERIEL CORP. ITS UNAUTHORIZED USE OR REPRODUCTION IN WHOLE OR IN PART IS STRICTLY FORBIDDEN.

REQ. PER UNIT

1

VOX-5

USED ON

MODEL

ASS'Y. NO.

DATE

5-1-62

NP-453 B

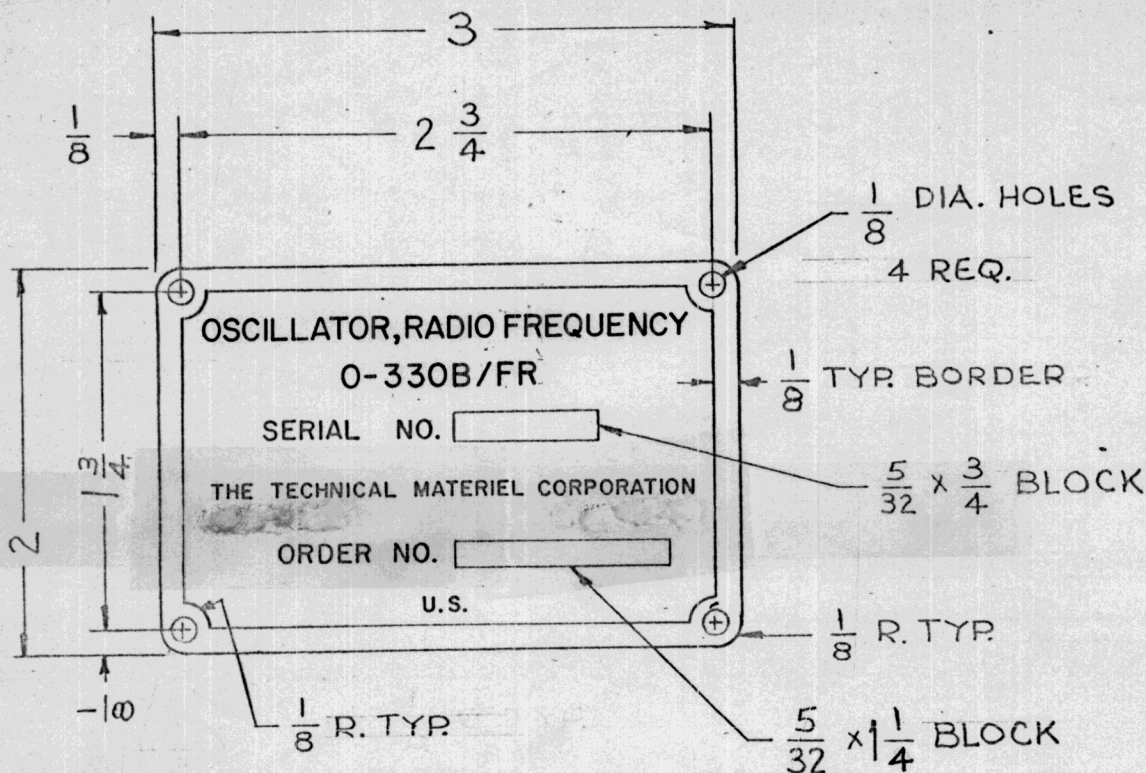

FINISH:
REVERSE ETCH, ANODIZE ON LUSTERLESS BLACK BACKGROUND (TYPE 37038) PER FED. STD. NO. 595
COLORLESS VARNISH PER MIL-V-6894

MINIMUM LETTER SIZE - 3/64 HIGH

APPLICABLE ORDER AND SERIAL NUMBER WILL BE STEEL STAMPED BY T M C.

NAMEPLATE TO BE IN ACCORDANCE WITH MIL-STD-130 AND MIL-M-13231A & AMENDS (REF: SIGNAL CORPS)

SYM	DESCRIPTION	DATE	CH. NO.	DRAFTS	CHECKER	ENG. APP.	REQ. ITEM	PART NO.	DESCRIPTION	SYMBOL
							.032		THE TECHNICAL MATERIEL CORP.	
B	5/32 X 1 1/4 BLOCK WAS 5/32 X 1 1/8 TYPE & TEMPER WAS 250	12.2.64	13034	MB	JBL	EDD	STOCK SIZE		MAMARONECK, NEW YORK	
A	MAM'K, N.Y. DELETED ON PICTORIAL	7-28-64	11955	Edm	@	EDD	ALUMINUM		NAMEPLATE, IDENTIFICATION	
							MATERIAL			
							5052 - H32		G. S	
							TYPE & TEMPER	HEATTREAT. SPEC.	DRAWN	CHECKED
							SEE NOTE			
							FINISH & SPEC. NO.		ELEC. DES. APP.	MECH. DES. APP.
										NP-453 B

UNLESS OTHERWISE SPECIFIED:

DIMENSIONS ARE IN INCHES

TOLERANCES ON

FRAC. ± 1/64 DEC. ± .005 ANGLES ± 1/2°

SCALE:

MAXIMUM ALLOWABLE TOLERANCES HAVE BEEN DETERMINED AND ANY DEVIATIONS WILL BE CAUSE FOR REJECTION.

REMOVE ALL BURRS AND SHARP EDGES

THE CONTENTS OF THIS DRAWING ARE THE EXCLUSIVE PROPERTY OF THE TECHNICAL MATERIEL CORP. ITS UNAUTHORIZED USE OR REPRODUCTION IN WHOLE OR IN PART IS STRICTLY FORBIDDEN.

REQ. PER UNIT
1

MODEL
SBE-3

USED ON

ASS'Y. NO.

DATE

5-3-62

NP-454

B

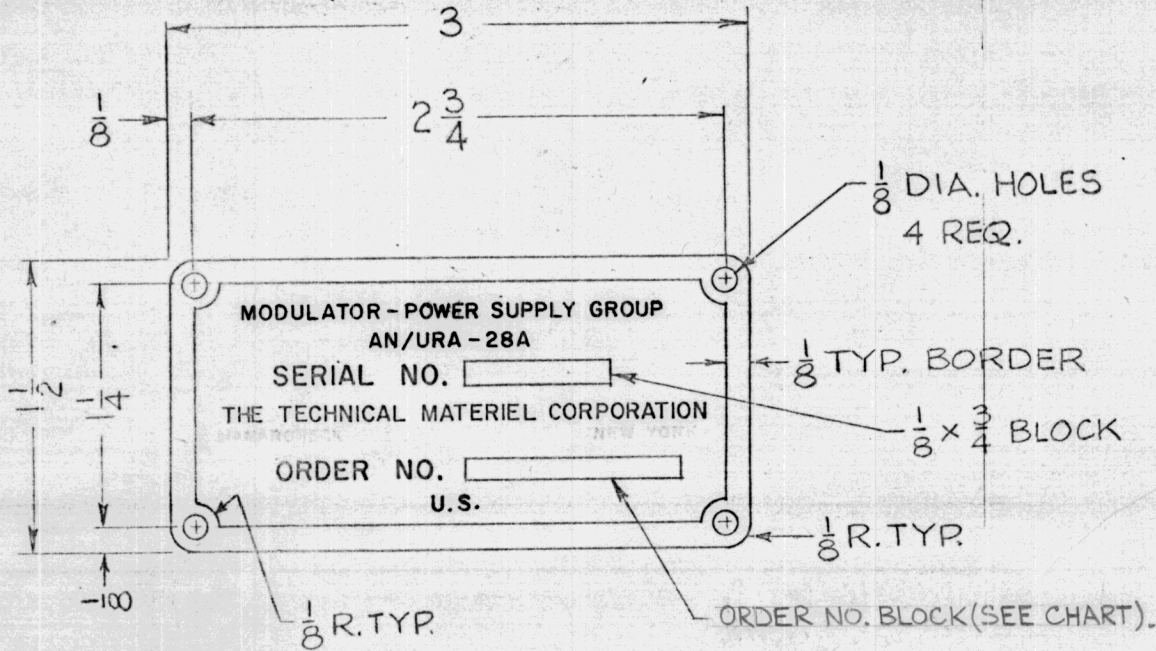

FINISH:
REVERSE ETCH, ANODIZE ON LUSTERLESS BLACK BACKGROUND (TYPE 37038)
PER FED. STD. NO. 595
COLORLESS VARNISH PER MIL-V-6894

MINIMUM LETTER SIZE - 3/64

APPLICABLE ORDER AND SERIAL NUMBER WILL BE STEEL STAMPED BY T M C.
OR
WHERE PURCHASING REQUIREMENT IS SUFFICIENTLY LARGE, ORDER NUMBER SHALL BE ETCHED BY VENDOR IN LIEU OF ORDER NUMBER BLOCK (SEE CHART FOR PROPER NUMBER).

TMC NO.	ORDER NO. BLOCK	ORDER NO. (ETCHED BY VENDOR)
NP-454-1	1/8 X 1-1/8 Block	No Order Number
NP-454-2	No Block	18002-PP-62

NAMEPLATE TO BE IN ACCORDANCE WITH MIL-STD-130 AND MIL-M-13231A (REF: SIGNAL CORPS)

REQ.	ITEM	PART NO.	DESCRIPTION	SYMBOL
		.032	THE TECHNICAL MATERIEL CORP.	
		STOCK SIZE	MAMARONECK, NEW YORK	
B	MAMK, N.Y. DELETED ON PICTORIAL	72864 11955	NAMEPLATE, IDENTIFICATION	
A	STOCK SIZE, MATL, & TYPE ADDED	724-62 6927	MODEL SBE-3	
SYM	DESCRIPTION	DATE	CH. NO.	DRAFTS
			CHECKER	ENG. APP.
UNLESS OTHERWISE SPECIFIED:		SCALE:		
DIMENSIONS ARE IN INCHES		MAXIMUM ALLOWABLE TOLERANCES HAVE BEEN DETERMINED AND ANY DEVIATIONS WILL BE CAUSE FOR REJECTION. REMOVE ALL BURRS AND SHARP EDGES		
FRAC. ± 1/64 DEC. ± .005 ANGLES ± 1/2°		250	TYPE & TEMPER	HEATTREAT. SPEC.
		SEE NOTE	DRAWN	CHECKED
		FINISH & SPEC. NO.	ELEC. DES. APP.	MECH. DES. APP.
				NP-454 B

THE CONTENTS OF THIS DRAWING ARE THE EXCLUSIVE PROPERTY OF THE TECHNICAL MATERIEL CORP. ITS UNAUTHORIZED USE OR REPRODUCTION IN WHOLE OR IN PART IS STRICTLY FORBIDDEN.

REQ. PER UNIT

1

MODEL

AO-101

USED ON

ASS'Y. NO.

DATE

5-2-62

NP-455

A

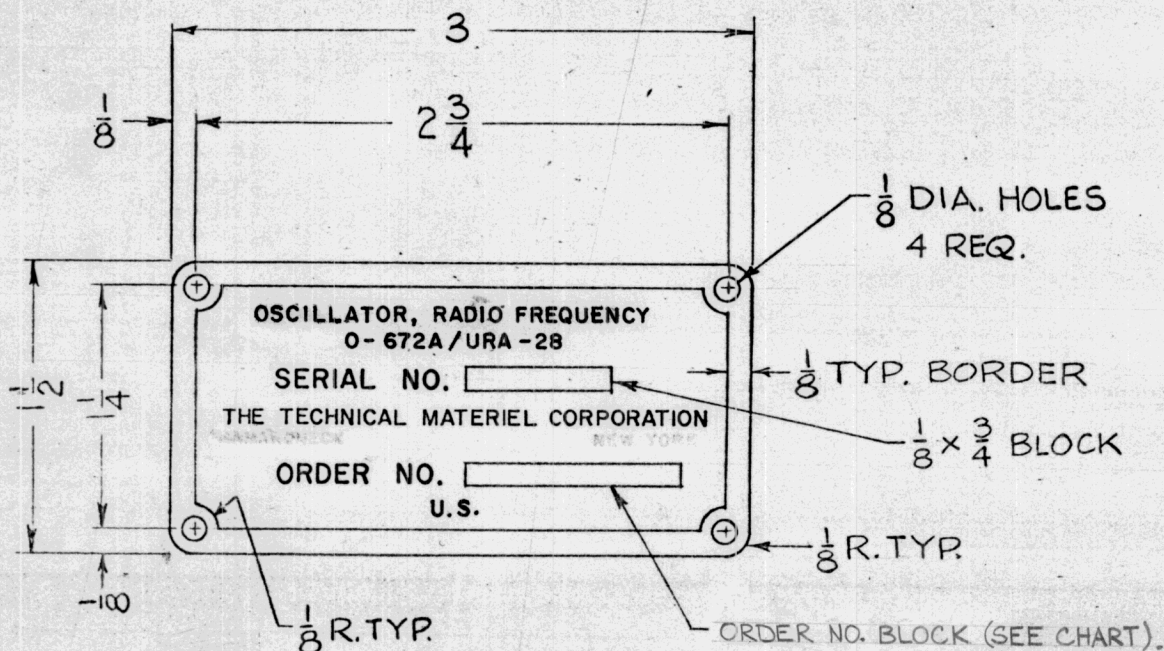

FINISH:
REVERSE ETCH, ANODIZE ON LUSTERLESS BLACK BACKGROUND (TYPE 37038)
PER FED. STD. NO. 595
COLORLESS VARNISH PER MIL-V-6894

MINIMUM LETTER SIZE - 3/64

APPLICABLE ORDER AND SERIAL NUMBER WILL BE STEEL STAMPED BY T M C.
OR-

WHERE PURCHASING REQUIREMENT IS SUFFICIENTLY LARGE, ORDER NUMBER SHALL BE ETCHED BY VENDOR IN LIEU OF ORDER NUMBER BLOCK (SEE CHART FOR PROPER NUMBER).

TMC NO.	ORDER NO. BLOCK	ORDER NO. (ETCHED BY VENDOR)
NP-455-1	1/8 X 1-1/8 Block	No Order Number
NP-455-2	No Block	18002-PP-62

NAMEPLATE TO BE IN ACCORDANCE WITH MIL-STD-130 AND MIL-M-13231A (REF: SIGNAL CORPS)

REQ.	ITEM	PART NO.	DESCRIPTION	SYMBOL
		.032	THE TECHNICAL MATERIEL CORP. MAMARONECK, NEW YORK	
		ALUMINUM	NAMEPLATE, IDENTIFICATION	
		250	MODEL AO-101	
		SEE NOTE	W.S. H.D. [Signature]	[Signature]
		FINISH & SPEC. NO.	DRAWN	CHECKED
			16	NP-455 A
			ELEC. DES. APP.	MECH. DES. APP.

UNLESS OTHERWISE SPECIFIED:
DIMENSIONS ARE IN INCHES
TOLERANCES ON
FRAC. ± 1/64 DEC. ± .005 ANGLES ± 1/2°

SCALE:
MAXIMUM ALLOWABLE TOLERANCES HAVE BEEN DETERMINED AND ANY DEVIATIONS WILL BE CAUSE FOR REJECTION.
REMOVE ALL BURRS AND SHARP EDGES

THE CONTENTS OF THIS DRAWING ARE THE EXCLUSIVE PROPERTY OF THE TECHNICAL MATERIEL CORP., ITS UNAUTHORIZED USE OR REPRODUCTION IN WHOLE OR IN PART IS STRICTLY FORBIDDEN.

REQ. PER UNIT

1

A-1397

USED ON

MODEL

ASS'Y. NO.

DATE

5-3-62

NP-456 | A

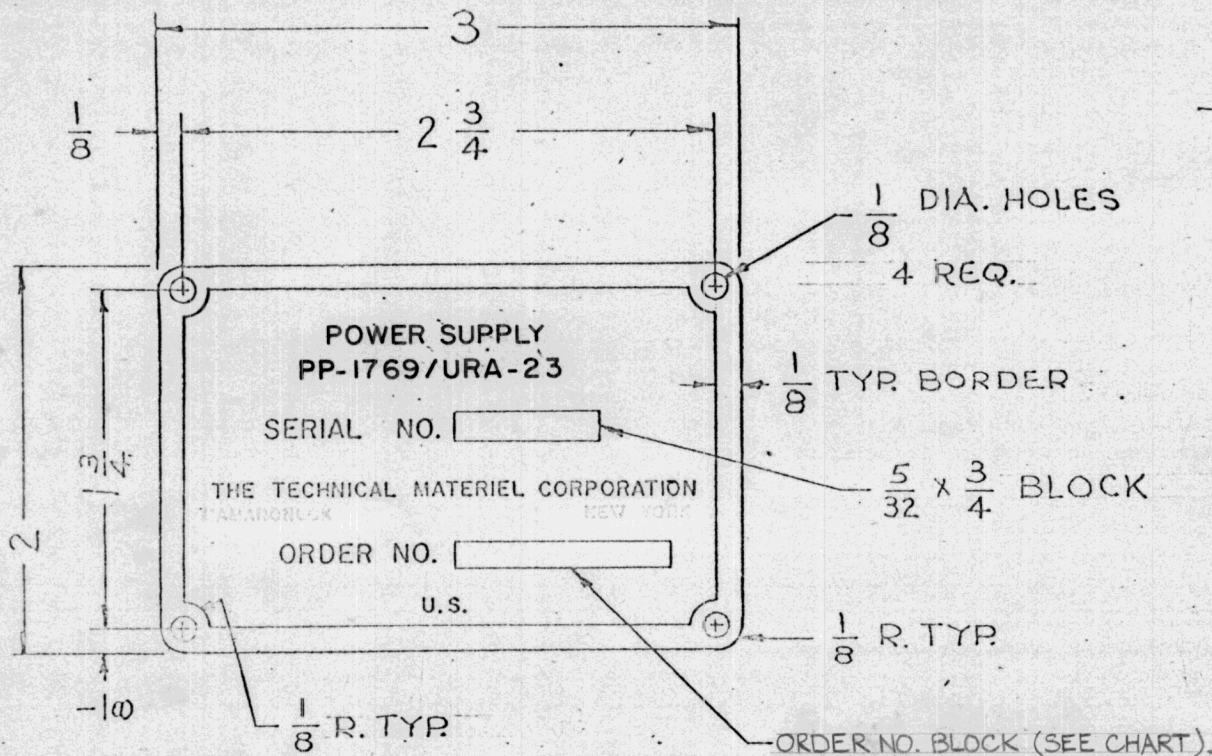

FINISH:
REVERSE ETCH, ANODIZE ON LUSTERLESS
BLACK BACKGROUND (TYPE 37038)
PER FED. STD. NO. 595
COLORLESS VARNISH PER MIL-V-6894

MINIMUM LETTER SIZE - 3/64 HIGH

APPLICABLE ORDER AND SERIAL NUMBER
WILL BE STEEL STAMPED BY T M C.
OR

WHERE PURCHASING REQUIREMENT IS
SUFFICIENTLY LARGE, ORDER NUMBER
SHALL BE ETCHED BY VENDOR IN LIEU
OF ORDER NUMBER BLOCK (SEE CHART
FOR PROPER NUMBER).

TMC NO.	ORDER NO. BLOCK	ORDER NO. (ETCHED BY VENDOR)
NP-456-1	5/32 X 1-1/8 Block	No Order Number
NP-456-2	No Block	18002-PP-62

NAMEPLATE TO BE IN ACCORDANCE WITH
MIL-STD-130 AND MIL-M-13231A
(REF: SIGNAL CORPS)

REQ.	ITEM	PART NO.	DESCRIPTION	SYMBOL					
		.032	THE TECHNICAL MATERIEL CORP. MAMARONECK, NEW YORK						
		ALUMINUM	NAMEPLATE, IDENTIFICATION						
		MODEL A-1397							
A	MAM'K, N.Y. DELETED ON PICTORIAL	728-64 11955	g.p.s. [Signature]						
SYM	DESCRIPTION	DATE	CH. NO.	DRAFTS	CHECKER	ENG. APP.			
UNLESS OTHERWISE SPECIFIED: DIMENSIONS ARE IN INCHES TOLERANCES ON FRAC. ± 1/64 DEC. ± .005 ANGLES ± 1/2°		SCALE: MAXIMUM ALLOWABLE TOLERANCES HAVE BEEN DETERMINED AND ANY DEVIATIONS WILL BE CAUSE FOR REJECTION. REMOVE ALL BURRS AND SHARP EDGES		TYPE & TEMPER		HEAT TREAT. SPEC.	DRAWN	CHECKED	FINAL APPROVAL
				SEE NOTE			16		NP-456 A
				FINISH & SPEC. NO.		ELEC. DES. APP.	MECH. DES. APP.		

THE CONTENTS OF THIS DRAWING ARE THE EXCLUSIVE PROPERTY OF THE TECHNICAL MATERIEL CORP. ITS UNAUTHORIZED USE OR REPRODUCTION IN WHOLE OR IN PART IS STRICTLY FORBIDDEN.

REQ. PER UNIT	USED ON		
	MODEL	ASS'Y. NO.	DATE
1	MCP-2		5-3-62

NP-457 | A

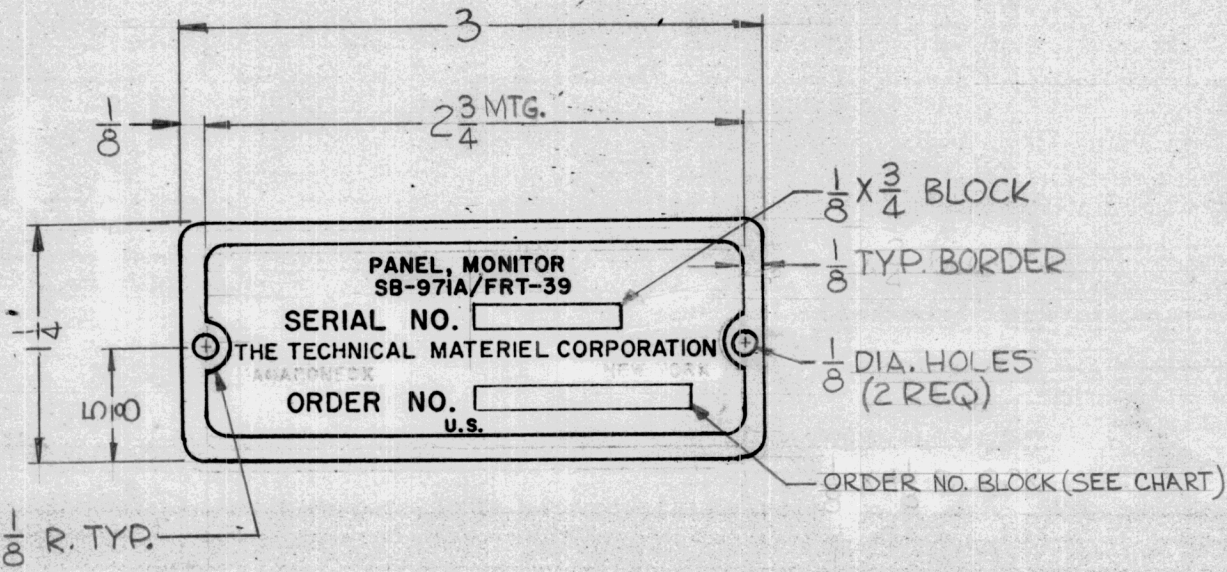

FINISH:
 REVERSE ETCH, ANODIZE ON LUSTERLESS BLACK BACKGROUND (TYPE 37038) PER FED. STD. NO. 595
 COLORLESS VARNISH PER MIL-V-6894

MINIMUM LETTER SIZE - 3/64 HIGH

APPLICABLE ORDER AND SERIAL NUMBER WILL BE STEEL STAMPED BY T M C.
 OR
 WHERE PURCHASING REQUIREMENT IS SUFFICIENTLY LARGE, ORDER NUMBER SHALL BE ETCHED BY VENDOR IN LIEU OF ORDER NUMBER BLOCK (SEE CHART FOR PROPER NUMBER).

TMC NO.	ORDER NO. BLOCK	ORDER NO. (ETCHED BY VENDOR)
NP-457-1	1/8 X 1-1/8 Block	No Order Number
NP-457-2	No Block	18002-PP-62

NAMEPLATE TO BE IN ACCORDANCE WITH MIL-STD-130 AND MIL-M-13231A (REF: SIGNAL CORPS)

REQ.	ITEM	PART NO.	DESCRIPTION	SYMBOL
		.032	THE TECHNICAL MATERIEL CORP.	
		STOCK SIZE	MAMARONECK, NEW YORK	
		ALUMINUM	NAMEPLATE, IDENTIFICATION	
		MATERIAL	MODEL MCP-2	
A	HAMIK, N.Y. DELETED ON PICTORIAL	7-2864 11955		
SYM	DESCRIPTION	DATE	CH. NO.	DRAFTS
			CHECKER	ENG. APP.
UNLESS OTHERWISE SPECIFIED:		SCALE:		
DIMENSIONS ARE IN INCHES		MAXIMUM ALLOWABLE TOLERANCES HAVE BEEN DETERMINED AND ANY DEVIATIONS WILL BE CAUSE FOR REJECTION.		
TOLERANCES ON		REMOVE ALL BURRS AND SHARP EDGES		
FRAC. ± 1/64 DEC. ± .005 ANGLES ± 1/2°				
	250		GG	
	TYPE & TEMPER	HEATTREAT.SPEC.	DRAWN	CHECKED
	SEE NOTE			
	FINISH & SPEC. NO.	ELEC. DES. APP.	MECH. DES. APP.	
				NP-457 A

THE CONTENTS OF THIS DRAWING ARE THE EXCLUSIVE PROPERTY OF THE TECHNICAL MATERIEL CORP. ITS UNAUTHORIZED USE OR REPRDUCTION IN WHOLE OR IN PART IS STRICTLY FORBIDDEN.

REQ. PER UNIT
1

MODEL
TTG-2

USED ON

ASS'Y. NO.

DATE

5-3-62

NP-458 B

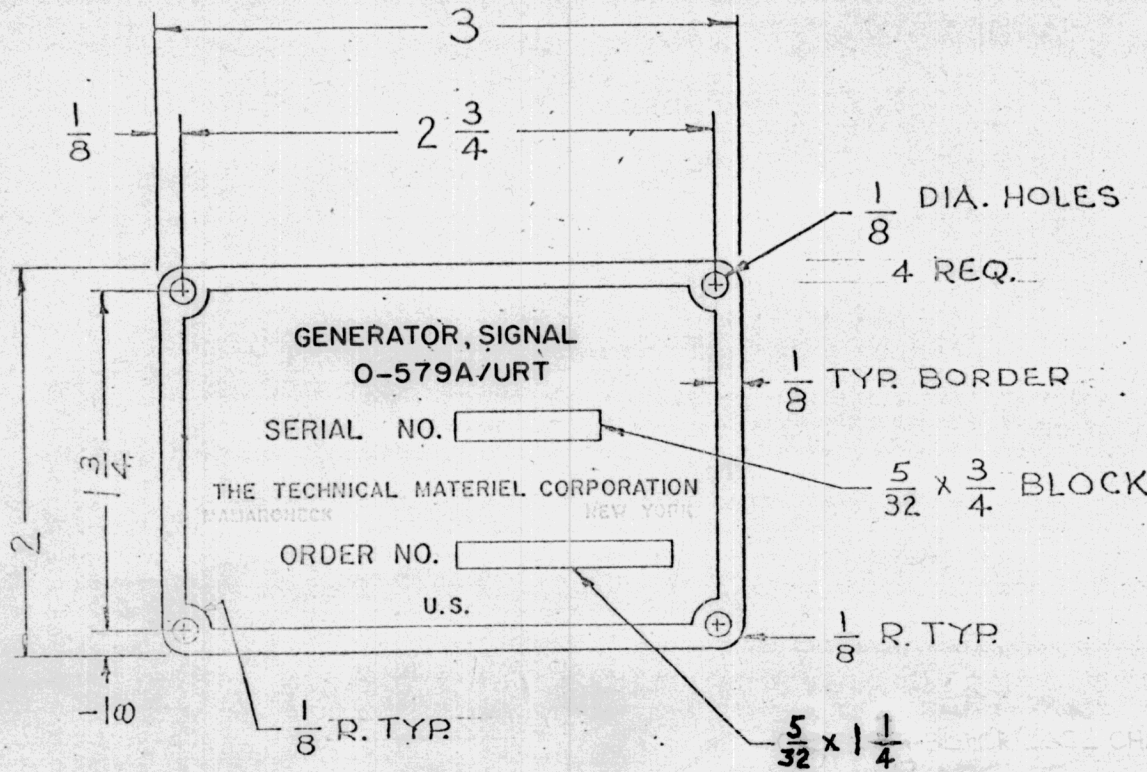

FINISH:
REVERSE ETCH, ANODIZE ON LUSTERLESS
BLACK BACKGROUND (TYPE 37038)
PER FED. STD. NO. 595
COLORLESS VARNISH PER MIL-V-6894

MINIMUM LETTER SIZE - 3/64 HIGH

APPLICABLE ORDER AND SERIAL NUMBER
WILL BE STEEL STAMPED BY T M C.

IF THE ORDERING REQUIREMENT IS
SUFFICIENTLY LARGE, CROSS REFERENCE
SHALL BE STAMPED BY VENDOR IN LINE
OF ORDER NUMBER BLOCK (SEE CHART
FOR PROPER NUMBER).

NAMEPLATE TO BE IN ACCORDANCE WITH
MIL-STD-130 AND MIL-M-13231A & AMENDS
(REF: SIGNAL CORPS)

ORDER NO.	12-3-64	13034	82	82	COO
ORDER NO.	72864	11955	82	@	COO

REQ.	ITEM	PART NO.	DESCRIPTION			SYMBOL
B		.032	THE TECHNICAL MATERIEL CORP. MAMARONECK, NEW YORK			
		STOCK SIZE				
A		ALUMINUM	NAMEPLATE, IDENTIFICATION			
		MATERIAL	MODEL TTG-2			
SYM	DESCRIPTION	DATE	CH. NO.	DRAFTS	CHECKER	ENG. APP.
	UNLESS OTHERWISE SPECIFIED: DIMENSIONS ARE IN INCHES TOLERANCES ON FRAC. ± 1/64 DEC. ± .005 ANGLES ± 1/2°	SCALE: MAXIMUM ALLOWABLE TOLERANCES HAVE BEEN DETERMINED AND ANY DEVIATIONS WILL BE CAUSE FOR REJECTION. REMOVE ALL BURRS AND SHARP EDGES				
		5052-H32			P.S	file
		TYPE & TEMPER	HEATTREAT.SPEC.	DRAWN	CHECKED	FINAL APPROVAL
		SEE NOTE			46	NP-458 B
		FINISH & SPEC. NO.	ELEC. DES. APP.	MECH. DES. APP.		

THE CONTENTS OF THIS DRAWING ARE THE EXCLUSIVE PROPERTY OF THE TECHNICAL MATERIEL CORP. ITS UNAUTHORIZED USE OR REPRODUCTION IN WHOLE OR IN PART IS STRICTLY FORBIDDEN.

REQ. PER UNIT

1

MODEL

FSA-2

USED ON

ASS'Y. NO.

DATE

5-3-62

NP-459

A

FINISH:

REVERSE ETCH, ANODIZE ON LUSTERLESS BLACK BACKGROUND (TYPE 37038) PER FED. STD. NO. 595
COLORLESS VARNISH PER MIL-V-6894

MINIMUM LETTER SIZE - 3/64 HIGH

APPLICABLE ORDER AND SERIAL NUMBER WILL BE STEEL STAMPED BY T M C.

OR

WHERE PURCHASING REQUIREMENT IS SUFFICIENTLY LARGE, ORDER NUMBER SHALL BE ETCHED BY VENDOR IN LIEU OF ORDER NUMBER BLOCK (SEE CHART FOR PROPER NUMBER).

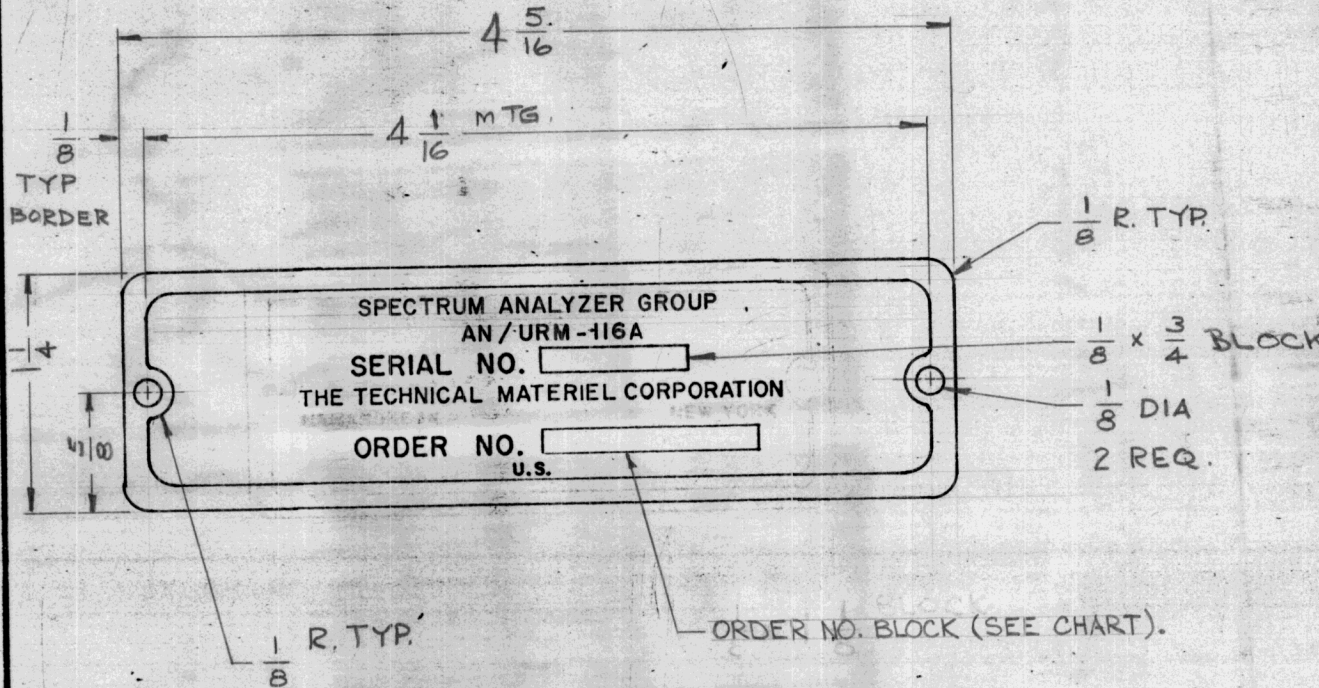

TMC NO.	ORDER NO. BLOCK	ORDER NO. (ETCHED BY VENDOR)
NP-459-1	1/8 X 1-1/8 Block	No Order Number
NP-459-2	No Block	18002-PP-62

NAMEPLATE TO BE IN ACCORDANCE WITH MIL-STD-130 AND MIL-M-13231A (REF: SIGNAL CORPS)

REQ.	ITEM	PART NO.	DESCRIPTION	SYMBOL
		.032	THE TECHNICAL MATERIEL CORP. MAMARONECK, NEW YORK	
		STOCK SIZE		
A	MAM'K, N.Y. DELETED ON PICTORIAL	ALUMINUM	NAMEPLATE, IDENTIFICATION	
		MATERIAL	MODEL FSA-2	
		250	G.P.	
		TYPE & TEMPER	CHECKED	FINAL APPROVAL
		HEATTREAT. SPEC.		
		FINISH & SPEC. NO.	ELEC. DES. APP.	MECH. DES. APP.
		SEE NOTE	16	NP-459 A

SCALE: MAXIMUM ALLOWABLE TOLERANCES HAVE BEEN DETERMINED AND ANY DEVIATIONS WILL BE CAUSE FOR REJECTION. REMOVE ALL BURRS AND SHARP EDGES

THE CONTENTS OF THIS DRAWING ARE THE EXCLUSIVE PROPERTY OF THE TECHNICAL MATERIEL CORP. ITS UNAUTHORIZED USE OR REPRODUCTION IN WHOLE OR IN PART IS STRICTLY FORBIDDEN.

REQ. PER UNIT

1

MODEL

PS-2

USED ON

ASS'Y. NO.

DATE

5-3-62

NP-461

A

FINISH:
REVERSE ETCH, ANODIZE ON LUSTERLESS BLACK BACKGROUND (TYPE 37038) PER FED. STD. NO. 595
COLORLESS VARNISH PER MIL-V-6894

MINIMUM LETTER SIZE - 3/64 HIGH

APPLICABLE ORDER AND SERIAL NUMBER WILL BE STEEL STAMPED BY T M C.

OR

WHERE PURCHASING REQUIREMENT IS SUFFICIENTLY LARGE, ORDER NUMBER SHALL BE ETCHED BY VENDOR IN LIEU OF ORDER NUMBER BLOCK (SEE CHART FOR PROPER NUMBER).

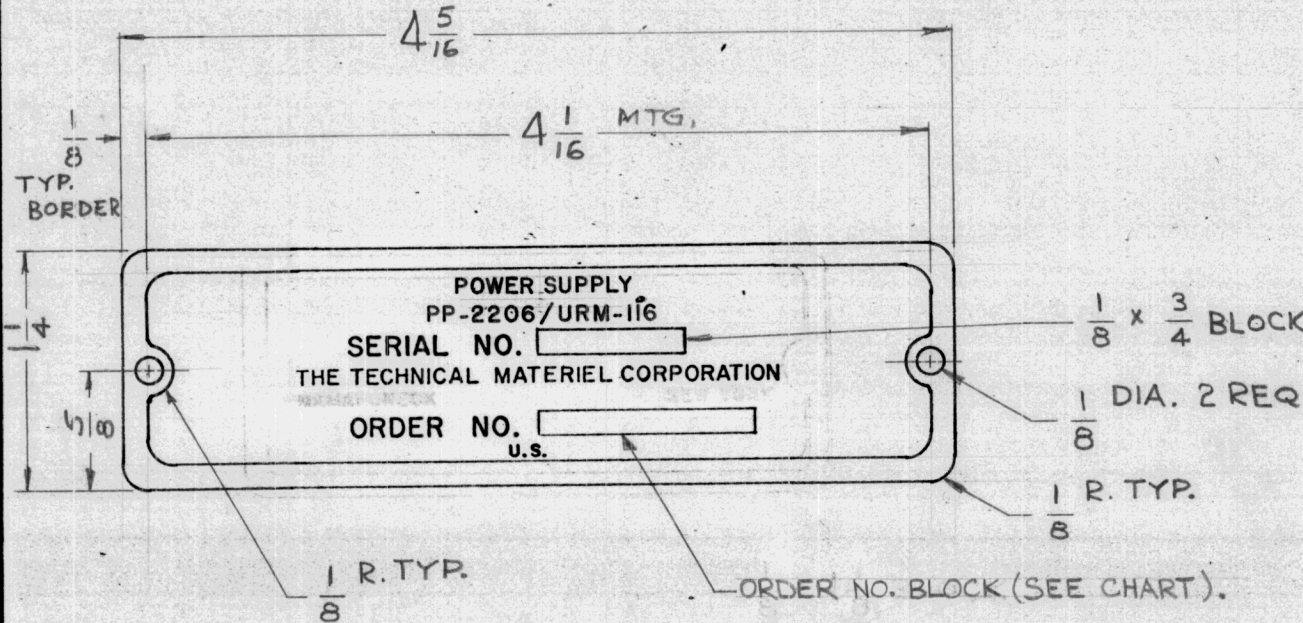

TMC NO.	ORDER NO. BLOCK	ORDER NO. (ETCHED BY VENDOR)
NP-461-1	1/8 X 1-1/8 Block	No Order Number
NP-461-2	No Block	18002-PP-62

NAMEPLATE TO BE IN ACCORDANCE WITH MIL-STD-130 AND MIL-M-13231A (REF: SIGNAL CORPS)

REQ.	ITEM	PART NO.	DESCRIPTION	SYMBOL
		.032	THE TECHNICAL MATERIEL CORP. MAMARONECK, NEW YORK	
		STOCK SIZE		
		ALUMINUM	NAMEPLATE, IDENTIFICATION	
		MATERIAL		
		250	MODEL PS-2	
		G.S.	FILE	SAW BL
		TYPE & TEMPER	DRAWN	CHECKED
		HEATTREAT. SPEC.		FINAL APPROVAL
		SEE NOTE		NP-461
		FINISH & SPEC. NO.	ELEC. DES. APP.	MECH. DES. APP.
				A

UNLESS OTHERWISE SPECIFIED:
DIMENSIONS ARE IN INCHES
TOLERANCES ON
FRAC. ± 1/64 DEC. ± .005 ANGLES ± 1/2°

SCALE:
MAXIMUM ALLOWABLE TOLERANCES HAVE BEEN DETERMINED AND ANY DEVIATIONS WILL BE CAUSE FOR REJECTION.
REMOVE ALL BURRS AND SHARP EDGES

THE CONTENTS OF THIS DRAWING ARE THE EXCLUSIVE PROPERTY OF THE TECHNICAL MATERIEL CORP. ITS UNAUTHORIZED USE OR REPRODUCTION IN WHOLE OR IN PART IS STRICTLY FORBIDDEN.

REQ. PER UNIT

1 PAL-1KA

USED ON

MODEL

ASS'Y. NO.

DATE

5-3-62

NP-462 | A

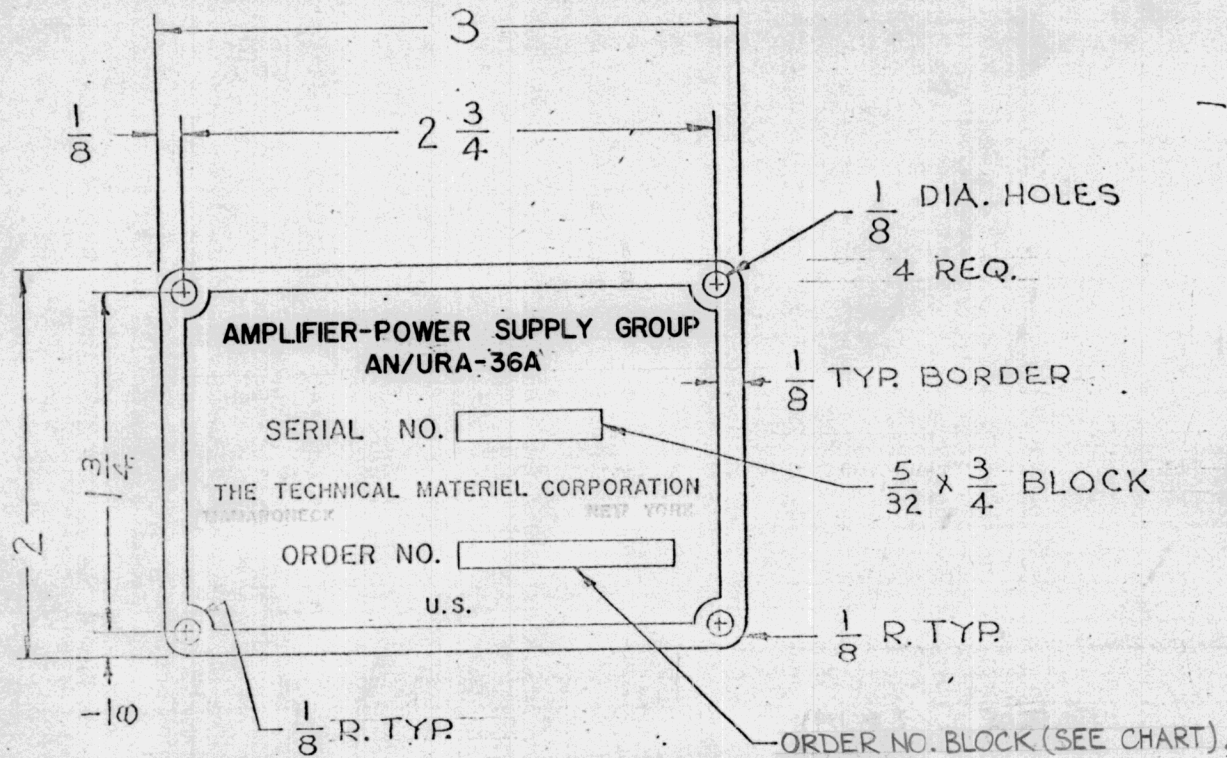

FINISH:
REVERSE ETCH, ANODIZE ON LUSTERLESS
BLACK BACKGROUND (TYPE 37038)
PER FED. STD. NO. 595
COLORLESS VARNISH PER MIL-V-6894

MINIMUM LETTER SIZE - 3/64 HIGH

APPLICABLE ORDER AND SERIAL NUMBER
WILL BE STEEL STAMPED BY T M C.

OR
WHERE PURCHASING REQUIREMENT IS
SUFFICIENTLY LARGE, ORDER NUMBER
SHALL BE ETCHED BY VENDOR IN LIEU
OF ORDER NUMBER BLOCK (SEE CHART
FOR PROPER NUMBER).

TMC NO.	ORDER NO. BLOCK	ORDER NO. (ETCHED BY VENDOR)
NP-462-1	5/32 X 1-1/8 Block	No Order Number
NP-462-2	No Block	18002-PP-62

NAMEPLATE TO BE IN ACCORDANCE WITH
MIL-STD-130 AND MIL-M-13231A
(REF: SIGNAL CORPS)

SYM	DESCRIPTION	DATE	CH. NO.	DRAFTS	CHECKER	ENG. APP.	REQ.	ITEM	PART NO.	DESCRIPTION	SYMBOL
									.032	THE TECHNICAL MATERIEL CORP. MAMARONECK, NEW YORK	
									STOCK SIZE		
									ALUMINUM	NAMEPLATE, IDENTIFICATION	
									MATERIAL	MODEL PAL-1KA	
A	MAM'K, N.Y. DELETED ON PICTORIAL	7/28/64	11955						2SO	P.S.	
									TYPE & TEMPER	CHECKED	
									HEAT TREAT. SPEC.		
									SEE NOTE		
									FINISH & SPEC. NO.	ELEC. DES. APP.	
										MECH. DES. APP.	
											NP-462 A

UNLESS OTHERWISE SPECIFIED:
DIMENSIONS ARE IN INCHES
TOLERANCES ON
FRAC. ± 1/64 DEC. ± .003 ANGLES ± 1/2°

SCALE:
MAXIMUM ALLOWABLE TOLERANCES HAVE
BEEN DETERMINED AND ANY DEVIATIONS
WILL BE CAUSE FOR REJECTION.
REMOVE ALL BURRS AND SHARP EDGES

THE CONTENTS OF THIS DRAWING ARE THE EXCLUSIVE PROPERTY OF THE TECHNICAL MATERIEL CORP. ITS UNAUTHORIZED USE OR REPRODUCTION IN WHOLE OR IN PART IS STRICTLY FORBIDDEN.

REQ. PER UNIT	USED ON			NP-463	A
	MODEL	ASS'Y. NO.	DATE		
	1	RFD-1A	5-3-62		

FINISH:
 REVERSE ETCH, ANODIZE ON LUSTERLESS BLACK BACKGROUND (TYPE 37038) PER FED. STD. NO. 595
 COLORLESS VARNISH PER MIL-V-6894

MINIMUM LETTER SIZE - 3/64 HIGH

APPLICABLE ORDER AND SERIAL NUMBER WILL BE STEEL STAMPED BY T M C.
 OR
 WHERE PURCHASING REQUIREMENT IS SUFFICIENTLY LARGE, ORDER NUMBER SHALL BE ETCHED BY VENDOR IN LIEU OF ORDER NUMBER BLOCK (SEE CHART FOR PROPER NUMBER).

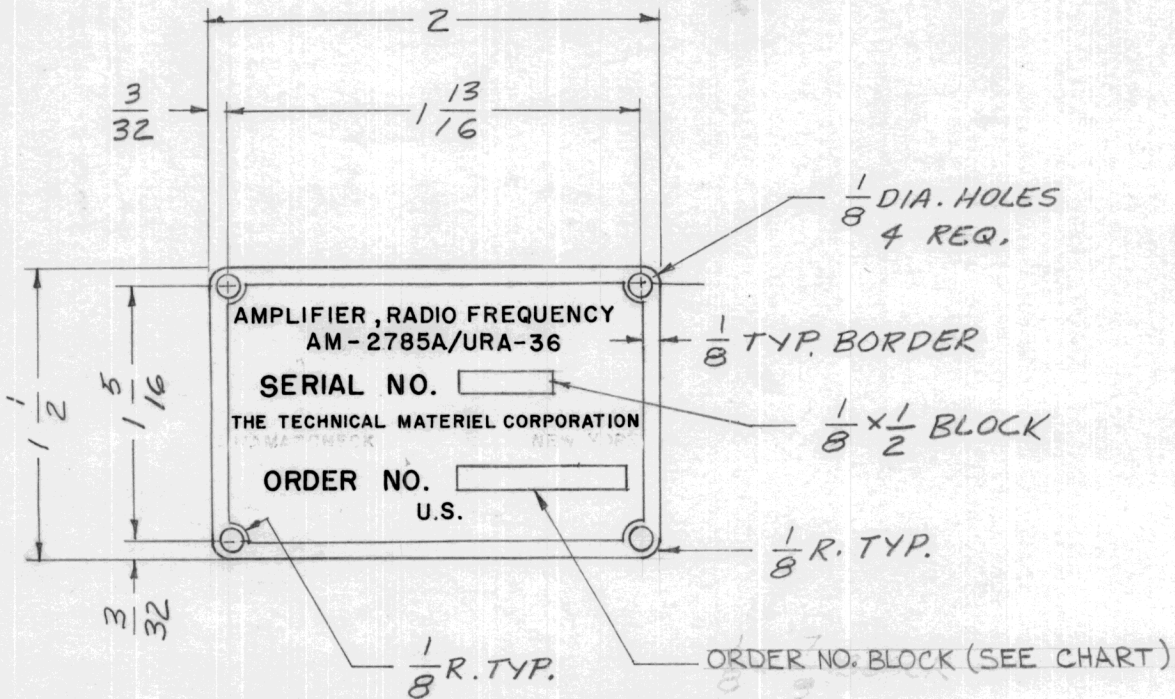

TMC NO.	ORDER NO. BLOCK	ORDER NO. (ETCHED BY VENDOR)
NP-463-1	1/8 X 1-1/8 Block	No Order Number
NP-463-2	No Block	18002-PP-62

NAMEPLATE TO BE IN ACCORDANCE WITH MIL-STD-130 AND MIL-M-13231A (REF: SIGNAL CORPS)

REQ.	ITEM	PART NO.	DESCRIPTION			SYMBOL
		.032	THE TECHNICAL MATERIEL CORP. MAMARONECK, NEW YORK			
		STOCK SIZE	NAMEPLATE, IDENTIFICATION			
A	MAM'K, N.Y. DELETED ON PICTORIAL	ALUMINUM	MODEL RFD-1A			
SYM	DESCRIPTION	DATE	CH. NO.	DRAFTS	CHECKER	ENG. APP.
	UNLESS OTHERWISE SPECIFIED: DIMENSIONS ARE IN INCHES TOLERANCES ON FRAC. ± 1/64 DEC. ± .005 ANGLES ± 1/2°	SCALE:	MAXIMUM ALLOWABLE TOLERANCES HAVE BEEN DETERMINED AND ANY DEVIATIONS WILL BE CAUSE FOR REJECTION. REMOVE ALL BURRS AND SHARP EDGES			
		250	W.S.	JHE	SEM	BB
		TYPE & TEMPER	HEATTREAT. SPEC.	DRAWN	CHECKED	FINAL APPROVAL
		SEE NOTE			LG	NP-463 A
		FINISH & SPEC. NO.	ELEC. DES. APP.	MECH. DES. APP.		

THE CONTENTS OF THIS DRAWING ARE THE EXCLUSIVE PROPERTY OF THE TECHNICAL MATERIEL CORP. ITS UNAUTHORIZED USE OR REPRODUCTION IN WHOLE OR IN PART IS STRICTLY FORBIDDEN.

REQ. PER UNIT 1	MODEL PS-4A	USED ON		DATE 5-3-62	NP-464 B
		ASS'Y. NO.			

FINISH:
 REVERSE ETCH, ANODIZE ON LUSTERLESS
BLACK BACKGROUND (TYPE **37038**)
 PER FED. STD. NO. 595
 COLORLESS VARNISH PER MIL-V-6894

MINIMUM LETTER SIZE - 3/64 HIGH

APPLICABLE ORDER AND SERIAL NUMBER
 WILL BE STEEL STAMPED BY T M C.
 OR

WHERE PURCHASING REQUIREMENT IS
 SUFFICIENTLY LARGE, ORDER NUMBER
 SHALL BE ETCHED BY VENDOR IN LIEU
 OF ORDER NUMBER BLOCK (SEE CHART
 FOR PROPER NUMBER).

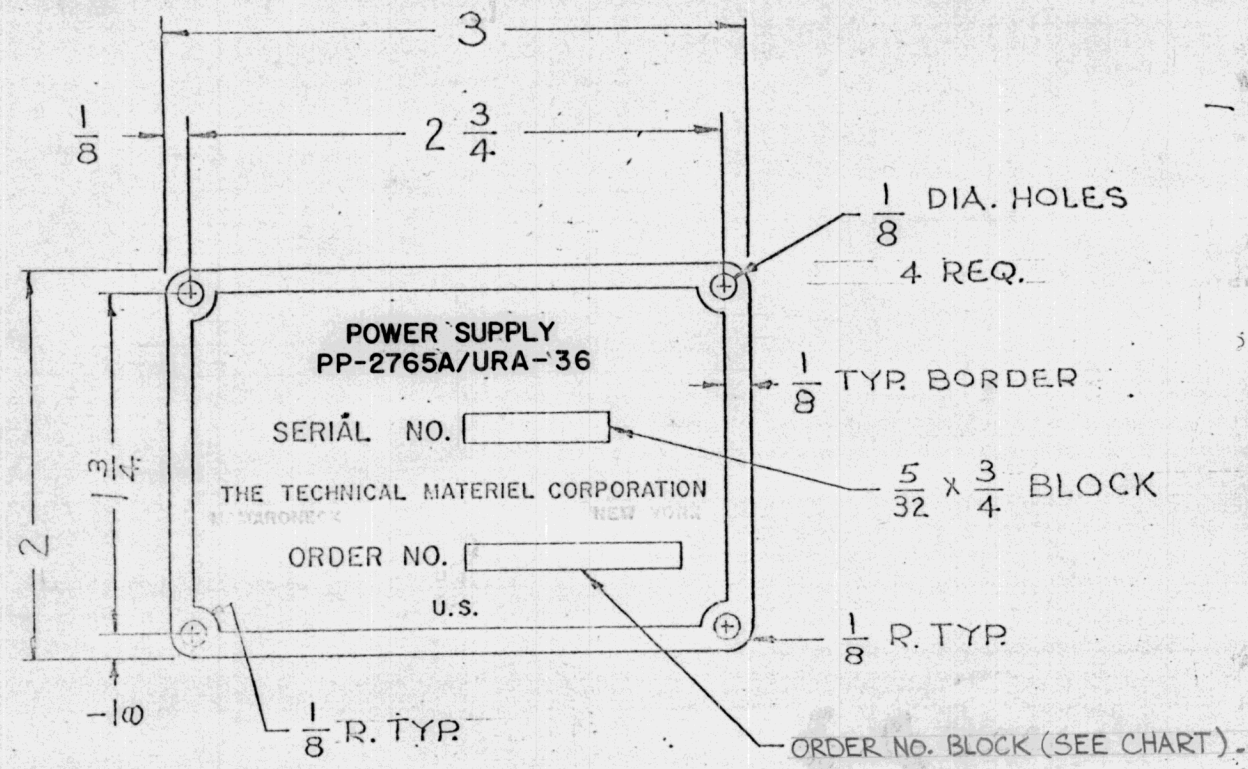

TMC NO.	ORDER NO. BLOCK	ORDER NO. (ETCHED BY VENDOR)
NP-464-1	5/32 X 1-1/8 Block	No Order Number
NP-464-2	No Block	18002-PP-62

NAMEPLATE TO BE IN ACCORDANCE WITH
 MIL-STD-130 AND MIL-M-13231A
 (REF: SIGNAL CORPS)

SYM	DESCRIPTION	DATE	CH. NO.	DRAFTS	CHECKER	ENG. APP.	REQ. ITEM	PART NO.	DESCRIPTION	SYMBOL
B	TYPE & TEMPER WAS 250	11/3/66	17148	RME	<i>[Signature]</i>	<i>[Signature]</i>	.032		THE TECHNICAL MATERIEL CORP. MAMARONECK, NEW YORK	NAMEPLATE, IDENTIFICATION
A	MAM'K, N.Y. DELETED ON PICTORIAL	7-28-64	11955	<i>[Signature]</i>	<i>[Signature]</i>	<i>[Signature]</i>	ALUMINUM			
									MODEL PS-4A	
							5052 H32		P.S.	<i>[Signature]</i>
							TYPE & TEMPER	HEAT TREAT. SPEC.	DRAWN	CHECKED
							SEE NOTE			
							FINISH & SPEC. NO.		ELEC. DES. APP.	MECH. DES. APP.
										NP-464 B

UNLESS OTHERWISE SPECIFIED:
 DIMENSIONS ARE IN INCHES
 TOLERANCES ON
 FRAC. ± 1/64 DEC. ± .005 ANGLES ± 1/2°

SCALE:
 MAXIMUM ALLOWABLE TOLERANCES HAVE BEEN DETERMINED AND ANY DEVIATIONS WILL BE CAUSE FOR REJECTION. REMOVE ALL BURRS AND SHARP EDGES

THE CONTENTS OF THIS DRAWING ARE THE EXCLUSIVE PROPERTY OF THE TECHNICAL MATERIEL CORP. ITS UNAUTHORIZED USE OR REPRODUCTION IN WHOLE OR IN PART IS STRICTLY FORBIDDEN.

REQ. PER UNIT

1 PS-5

USED ON

MODEL

ASS'Y. NO.

DATE

5-3-62

NP-465 B

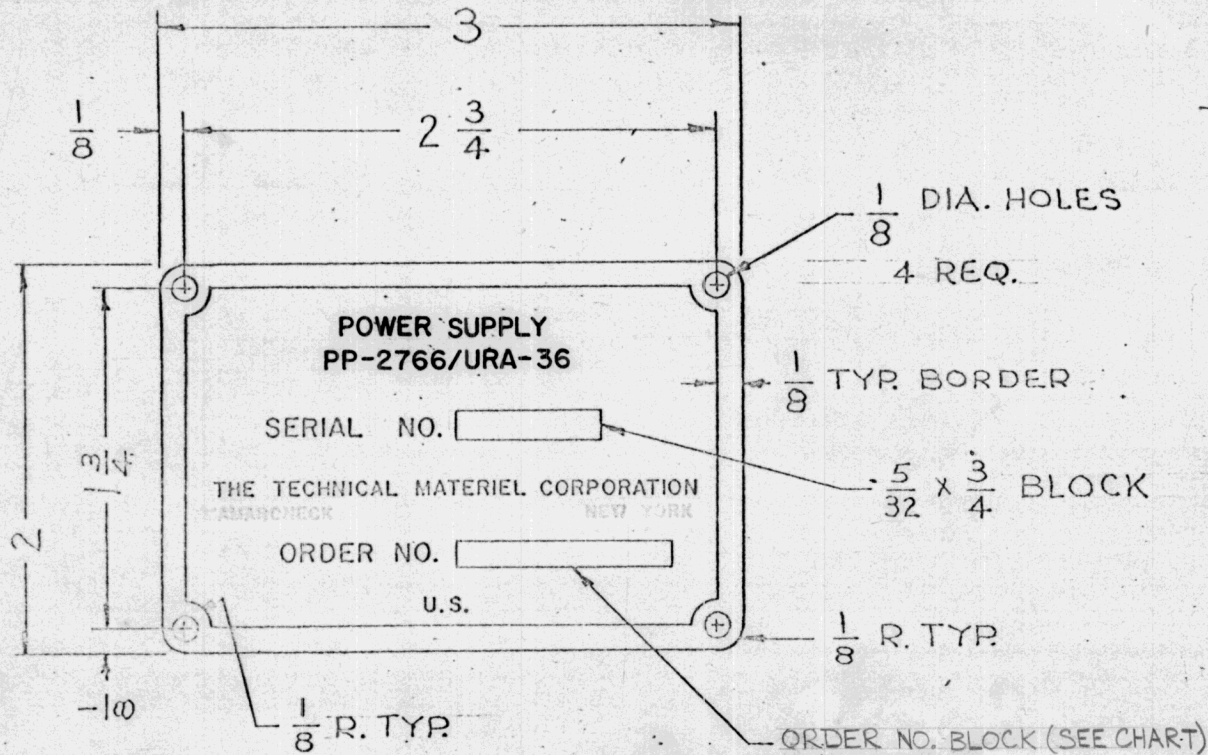

FINISH:
REVERSE ETCH, ANODIZE ON LUSTERLESS
BLACK BACKGROUND (TYPE **37038**)
PER FED. STD. NO. 595
COLORLESS VARNISH PER MIL-V-6894

MINIMUM LETTER SIZE - 3/64 HIGH

APPLICABLE ORDER AND SERIAL NUMBER
WILL BE STEEL STAMPED BY T M C.

OR

WHERE PURCHASING REQUIREMENT IS
SUFFICIENTLY LARGE, ORDER NUMBER
SHALL BE ETCHED BY VENDOR IN LIEU
OF ORDER NUMBER BLOCK (SEE CHART
FOR PROPER NUMBER).

TMC NO.	ORDER NO. BLOCK	ORDER NO. (ETCHED BY VENDOR)
NP-465-1	5/32 X 1-1/8 Block	No Order Number
NP-465-2	No Block	18002-PP-62

NAMEPLATE TO BE IN ACCORDANCE WITH
MIL-STD-130 AND MIL-M-13231A
(REF: SIGNAL CORPS)

REQ.	ITEM	PART NO.	DESCRIPTION	SYMBOL
		.032	THE TECHNICAL MATERIEL CORP. MAMARONECK, NEW YORK	
		STOCK SIZE		
B	TYPE & TEMPER WAS 250	11/3/66 17148 RME JCB	ALUMINUM	NAMEPLATE, IDENTIFICATION
A	MAM'K, N.Y. DELETED ON PICTORIAL	7-28-64 11955		MODEL PS-5
SYM	DESCRIPTION	DATE	CH. NO.	DRAFTS
			CHECKER	ENG. APP.
UNLESS OTHERWISE SPECIFIED:		SCALE:		
DIMENSIONS ARE IN INCHES		MAXIMUM ALLOWABLE TOLERANCES HAVE BEEN DETERMINED AND ANY DEVIATIONS WILL BE CAUSE FOR REJECTION. REMOVE ALL BURRS AND SHARP EDGES		
TOLERANCES ON				
FRAC. ± 1/64 DEC. ± .005 ANGLES ± 1/2°				
		5052-H32	G.P.S.	Joe Sam
		TYPE & TEMPER	DRAWN	CHECKED
		HEAT TREAT. SPEC.		FINAL APPROVAL
		SEE NOTE	16	NP-465 B
		FINISH & SPEC. NO.	ELEC. DES. APP.	MECH. DES. APP.

THE CONTENTS OF THIS DRAWING ARE THE EXCLUSIVE PROPERTY OF THE TECHNICAL MATERIEL CORP. ITS UNAUTHORIZED USE OR REPRODUCTION IN WHOLE OR IN PART IS STRICTLY FORBIDDEN.

REQ. PER UNIT

1

USED ON

MODEL

APP-1

ASS'Y. NO.

GPT-10K

DATE

5-3-62

NP-467/A

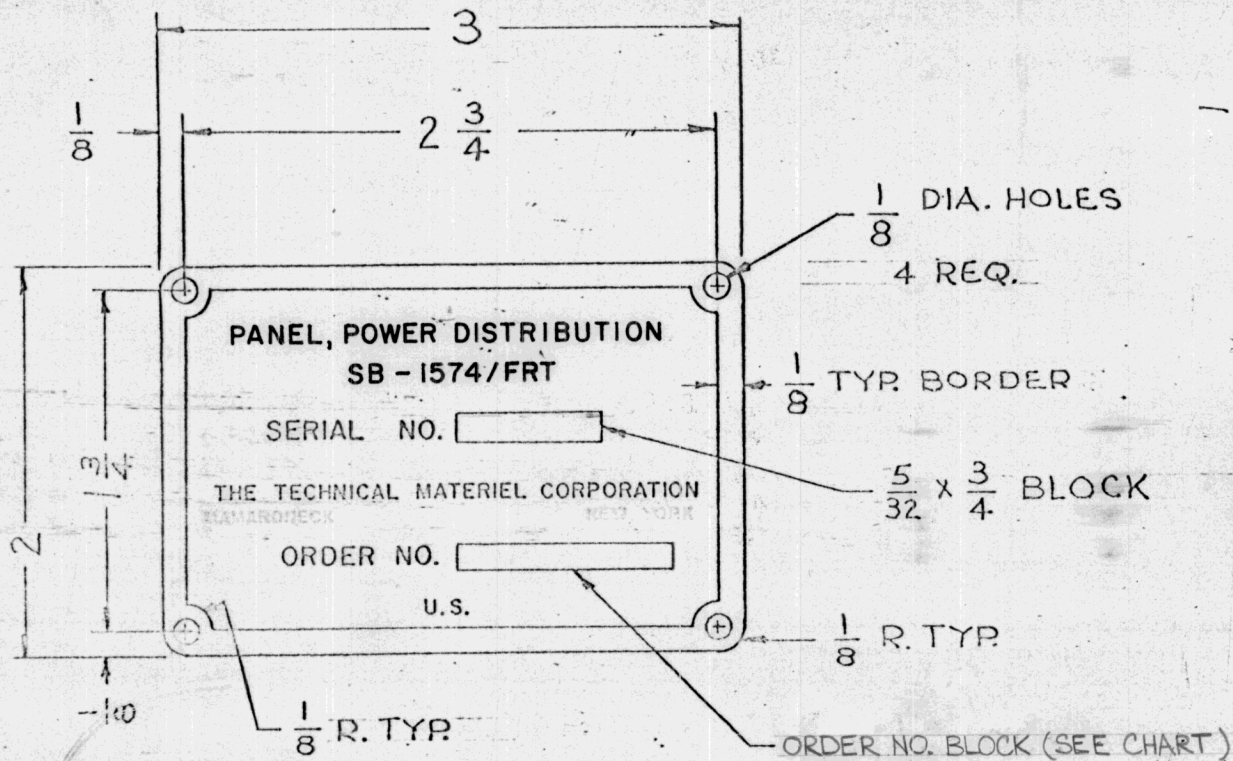

FINISH:
REVERSE ETCH, ANODIZE ON LUSTERLESS
BLACK BACKGROUND (TYPE 37038)
PER FED. STD. NO. 595
COLORLESS VARNISH PER MIL-V-6894

MINIMUM LETTER SIZE - 3/64 HIGH

APPLICABLE ORDER AND SERIAL NUMBER
WILL BE STEEL STAMPED BY T M C.

OR
WHERE PURCHASING REQUIREMENT IS
SUFFICIENTLY LARGE, ORDER NUMBER
SHALL BE ETCHED BY VENDOR IN LIEU
OF ORDER NUMBER BLOCK (SEE CHART
FOR PROPER NUMBER).

TMC NO.	ORDER NO. BLOCK	ORDER NO. (ETCHED BY VENDOR)
NP-467-1	5/32 X 1-1/8 Block	No Order Number
NP-467-2	No Block	18002-PP-62

NAMEPLATE TO BE IN ACCORDANCE WITH
MIL-STD-130 AND MIL-M-13231A
(REF: SIGNAL CORPS)

SYM	DESCRIPTION	DATE	CH. NO.	DRAFTS	CHECKER	ENG. APP.	REQ. ITEM	PART NO.	DESCRIPTION	SYMBOL	
							.032		THE TECHNICAL MATERIEL CORP. MAMARONECK, NEW YORK		
							ALUMINUM		NAMEPLATE, IDENTIFICATION		
									MODEL APP-1		
A	MAM'K N.Y. DELETED ON PICTORIAL	7-28-64	11955				250		G.S.		
							TYPE & TEMPER	HEAT TREAT. SPEC.	DRAWN	CHECKED	
							SEE NOTE				
							FINISH & SPEC. NO.		ELEC. DES. APP.	MECH. DES. APP.	
UNLESS OTHERWISE SPECIFIED: DIMENSIONS ARE IN INCHES TOLERANCES ON FRAC. ± 1/64 DEC. ± .005 ANGLES ± 1/2°							SCALE: MAXIMUM ALLOWABLE TOLERANCES HAVE BEEN DETERMINED AND ANY DEVIATIONS WILL BE CAUSE FOR REJECTION. REMOVE ALL BURRS AND SHARP EDGES				
										NP-467/A	

THE CONTENTS OF THIS DRAWING ARE THE EXCLUSIVE PROPERTY OF THE TECHNICAL MATERIEL CORP. ITS UNAUTHORIZED USE OR REPRODUCTION IN WHOLE OR IN PART IS STRICTLY FORBIDDEN.

REQ. PER UNIT

1 APP-4

USED ON

MODEL

ASS'Y. NO.

DATE

SBT-1K

5-3-62

NP-468 B

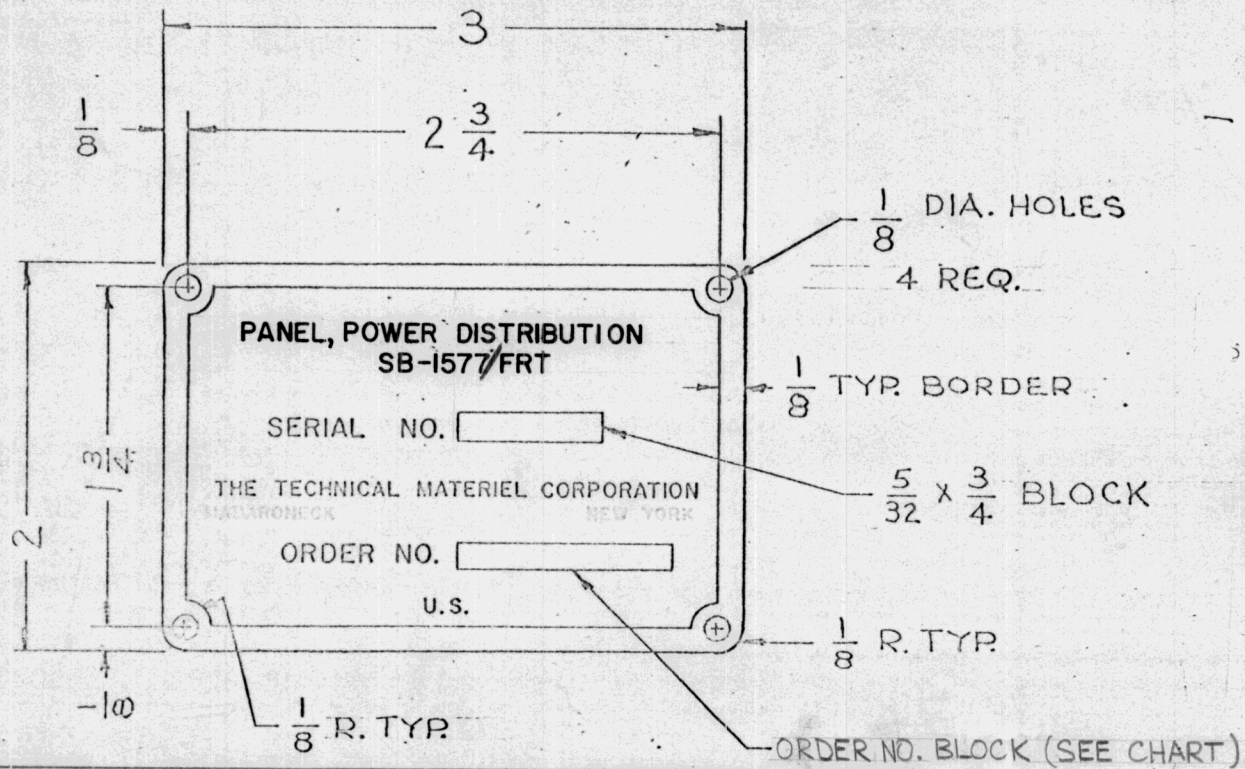

FINISH:
REVERSE ETCH, ANODIZE ON LUSTERLESS
BLACK BACKGROUND (TYPE 37038)
PER FED. STD. NO. 595
COLORLESS VARNISH PER MIL-V-6894

MINIMUM LETTER SIZE - 3/64 HIGH

APPLICABLE ORDER AND SERIAL NUMBER
WILL BE STEEL STAMPED BY T M C.
OR

WHERE PURCHASING REQUIREMENT IS
SUFFICIENTLY LARGE, ORDER NUMBER
SHALL BE ETCHED BY VENDOR IN LIEU
OF ORDER NUMBER BLOCK (SEE CHART
FOR PROPER NUMBER).

TMC NO.	ORDER NO. BLOCK	ORDER NO. (ETCHED BY VENDOR)
NP-468-1	5/32 X 1-1/8 Block	No Order Number
NP-468-2	No Block	18002-PP-62

NAMEPLATE TO BE IN ACCORDANCE WITH
MIL-STD-130 AND MIL-M-13231A
(REF: SIGNAL CORPS)

REQ.	ITEM	PART NO.	DESCRIPTION	SYMBOL									
		.032	THE TECHNICAL MATERIEL CORP. MAMARONECK, NEW YORK										
B	TYPE & TEMPER WAS Z50	11/3/66 17148 RME	ALUMINUM										
A	MAM'K, N.Y. DELETED ON PICTORIAL	728 64 11955	ALUMINUM										
SYM	DESCRIPTION	DATE	CH. NO.	DRAFTS	CHECKER	ENG. APP.	MATERIAL	MODEL APP-4,					
UNLESS OTHERWISE SPECIFIED: DIMENSIONS ARE IN INCHES TOLERANCES ON FRAC. ± 1/64 DEC. ± .003 ANGLES ± 1/2°		SCALE: MAXIMUM ALLOWABLE TOLERANCES HAVE BEEN DETERMINED AND ANY DEVIATIONS WILL BE CAUSE FOR REJECTION. REMOVE ALL BURRS AND SHARP EDGES		5052-H32		P.S.		JHE		SAM			
				TYPE & TEMPER		HEATTREAT.SPEC.		DRAWN		CHECKED		FINAL APPROVAL	
				SEE NOTE				66		NP-468 B			
				FINISH & SPEC. NO.		ELEC. DES. APP.		MECH. DES. APP.					

THE CONTENTS OF THIS DRAWING ARE THE EXCLUSIVE PROPERTY OF THE TECHNICAL MATERIEL CORP. ITS UNAUTHORIZED USE OR REPRODUCTION IN WHOLE OR IN PART IS STRICTLY FORBIDDEN.

REQ. PER UNIT	MODEL	USED ON ASS'Y. NO.	DATE
1	RAK-10A	SBT-1KJ	5-3-62

NP-469 | A

FINISH:
 REVERSE ETCH, ANODIZE ON LUSTERLESS
BLACK BACKGROUND (TYPE 37038)
 PER FED. STD. NO. 595
 COLORLESS VARNISH PER MIL-V-6894

MINIMUM LETTER SIZE - 3/64 HIGH

APPLICABLE ORDER AND SERIAL NUMBER
 WILL BE STEEL STAMPED BY T M C.
 OR

WHERE PURCHASING REQUIREMENT IS
 SUFFICIENTLY LARGE, ORDER NUMBER
 SHALL BE ETCHED BY VENDOR IN LIEU
 OF ORDER NUMBER BLOCK (SEE CHART
 FOR PROPER NUMBER).

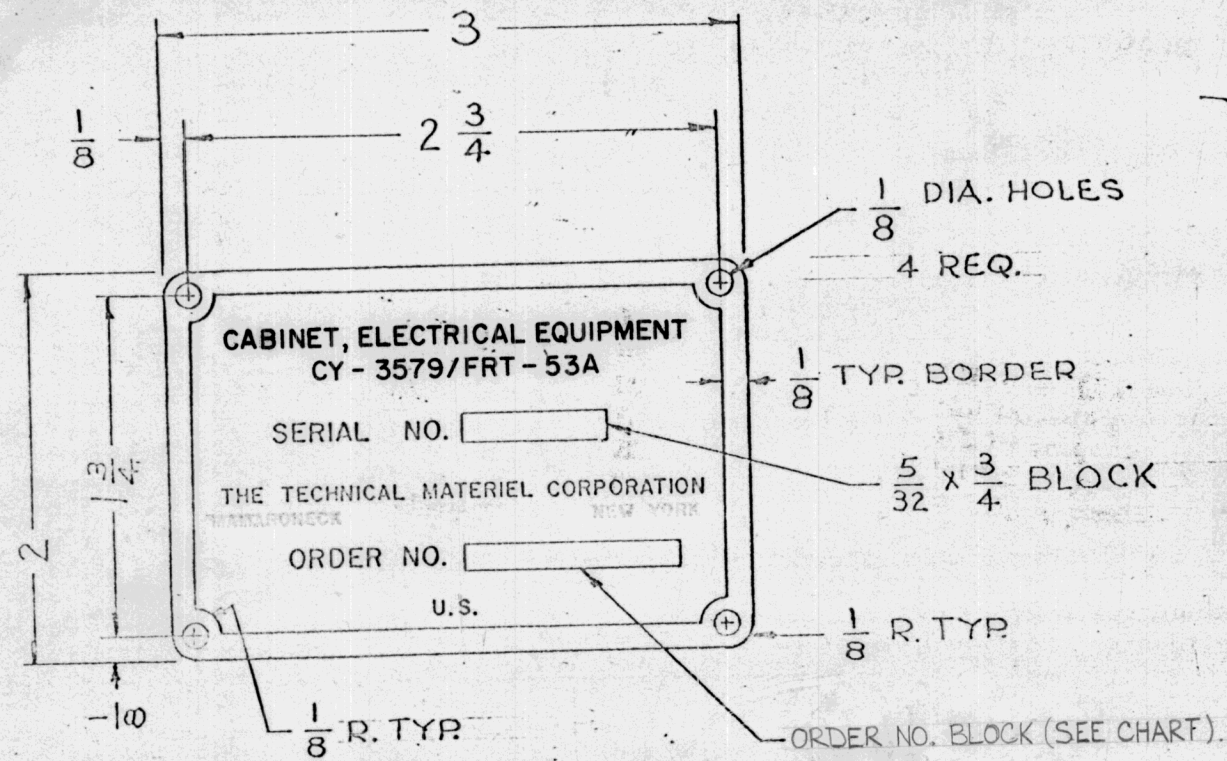

TMC NO.	ORDER NO. BLOCK	ORDER NO. (ETCHED BY VENDOR)
NP-469-1	5/32 X 1-1/8 Block	No Order Number
NP-469-2	No Block	18002-PP-62

NAMEPLATE TO BE IN ACCORDANCE WITH
 MIL-STD-130 AND MIL-M-13231A
 (REF: SIGNAL CORPS)

SYM	DESCRIPTION	DATE	CH. NO.	DRAFTS	CHECKER	ENG. APP.	REQ. ITEM	PART NO.	DESCRIPTION	SYMBOL
A	MAM'K, N.Y. DELETED ON PICTORIAL	7-28-62	11955				.032		THE TECHNICAL MATERIEL CORP. MAMARONECK, NEW YORK	
							STOCK SIZE			
							ALUMINUM		NAMEPLATE, IDENTIFICATION	
							MATERIAL		MODEL RAK-10A	
							250		G.P.S.	
							TYPE & TEMPER	HEATTREAT. SPEC.	DRAWN	CHECKED
							SEE NOTE			
							FINISH & SPEC. NO.		ELEC. DES. APP.	MECH. DES. APP.
UNLESS OTHERWISE SPECIFIED: DIMENSIONS ARE IN INCHES TOLERANCES ON FRAC. ± 1/64 DEC. ± .005 ANGLES ± 1/2°							SCALE: MAXIMUM ALLOWABLE TOLERANCES HAVE BEEN DETERMINED AND ANY DEVIATIONS WILL BE CAUSE FOR REJECTION. REMOVE ALL BURRS AND SHARP EDGES		FINAL APPROVAL NP-469 A	

THE CONTENTS OF THIS DRAWING ARE THE EXCLUSIVE PROPERTY OF THE TECHNICAL MATERIEL CORP., ITS UNAUTHORIZED USE OR REPRODUCTION IN WHOLE OR IN PART IS STRICTLY FORBIDDEN.

REQ. PER UNIT 1	USED ON		
	MODEL AX-262	ASS'Y. NO. GPT-10K	DATE 5-3-62

NP-470 | A

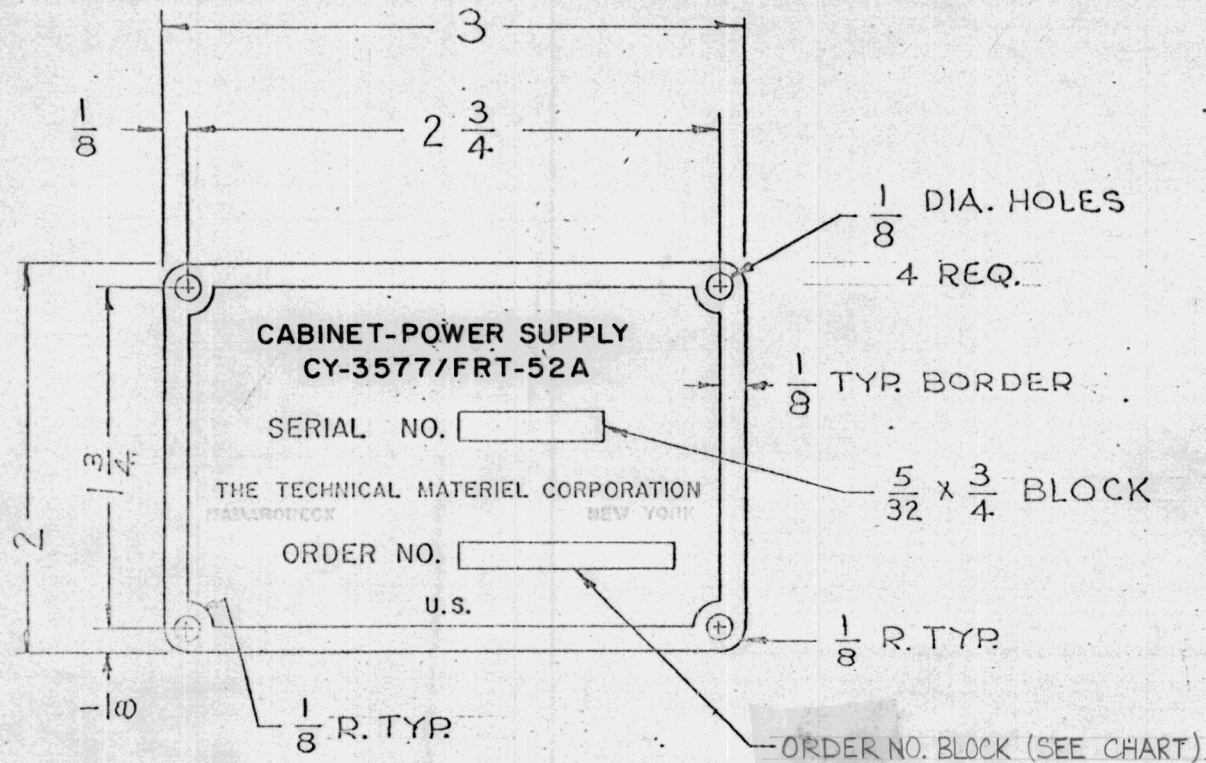

FINISH:
REVERSE ETCH, ANODIZE ON LUSTERLESS
BLACK BACKGROUND (TYPE 37038)
PER FED. STD. NO. 595
COLORLESS VARNISH PER MIL-V-6894

MINIMUM LETTER SIZE - 3/64 HIGH

APPLICABLE ORDER AND SERIAL NUMBER
WILL BE STEEL STAMPED BY T M C.
OR

WHERE PURCHASING REQUIREMENT IS
SUFFICIENTLY LARGE, ORDER NUMBER
SHALL BE ETCHED BY VENDOR IN LIEU
OF ORDER NUMBER BLOCK (SEE CHART
FOR PROPER NUMBER).

TMC NO.	ORDER NO. BLOCK	ORDER NO. (ETCHED BY VENDOR)
NP-470-1	5/32 X 1-1/8 Block	No Order Number
NP-470-2	No Block	18002-PP-62

NAMEPLATE TO BE IN ACCORDANCE WITH
MIL-STD-130 AND MIL-M-13231A
(REF: SIGNAL CORPS)

SYM	DESCRIPTION	DATE	CH. NO.	DRAFTS	CHECKER	ENG. APP.	REQ. ITEM	PART NO.	DESCRIPTION	SYMBOL
A	MAM'K, N.Y. DELETED ON PICTORIAL	7-25-64	11955					.032	THE TECHNICAL MATERIEL CORP. MAMARONECK, NEW YORK	
								STOCK SIZE		
								ALUMINUM	NAMEPLATE, IDENTIFICATION	
								MATERIAL	MODEL AX-262	
							250		G.P.S.	
							TYPE & TEMPER	HEATTREAT. SPEC.	DRAWN	CHECKED
							SEE NOTE			
							FINISH & SPEC. NO.	ELEC. DES. APP.	MECH. DES. APP.	

UNLESS OTHERWISE SPECIFIED:
DIMENSIONS ARE IN INCHES
TOLERANCES ON
FRAC. $\pm 1/64$ DEC. $\pm .003$ ANGLES $\pm 1/2^\circ$

SCALE:
MAXIMUM ALLOWABLE TOLERANCES HAVE
BEEN DETERMINED AND ANY DEVIATIONS
WILL BE CAUSE FOR REJECTION.
REMOVE ALL BURRS AND SHARP EDGES

250
G.P.S.
DRAWN
CHECKED
FINAL APPROVAL
NP-470 | A

THE CONTENTS OF THIS DRAWING ARE THE EXCLUSIVE PROPERTY OF THE TECHNICAL MATERIEL CORP. ITS UNAUTHORIZED USE OR REPRODUCTION IN WHOLE OR IN PART IS STRICTLY FORBIDDEN.

REQ. PER UNIT	USED ON		
	MODEL	ASS'Y. NO.	DATE
1	AX-263	GPT-401K	5-3-62

NP-471A

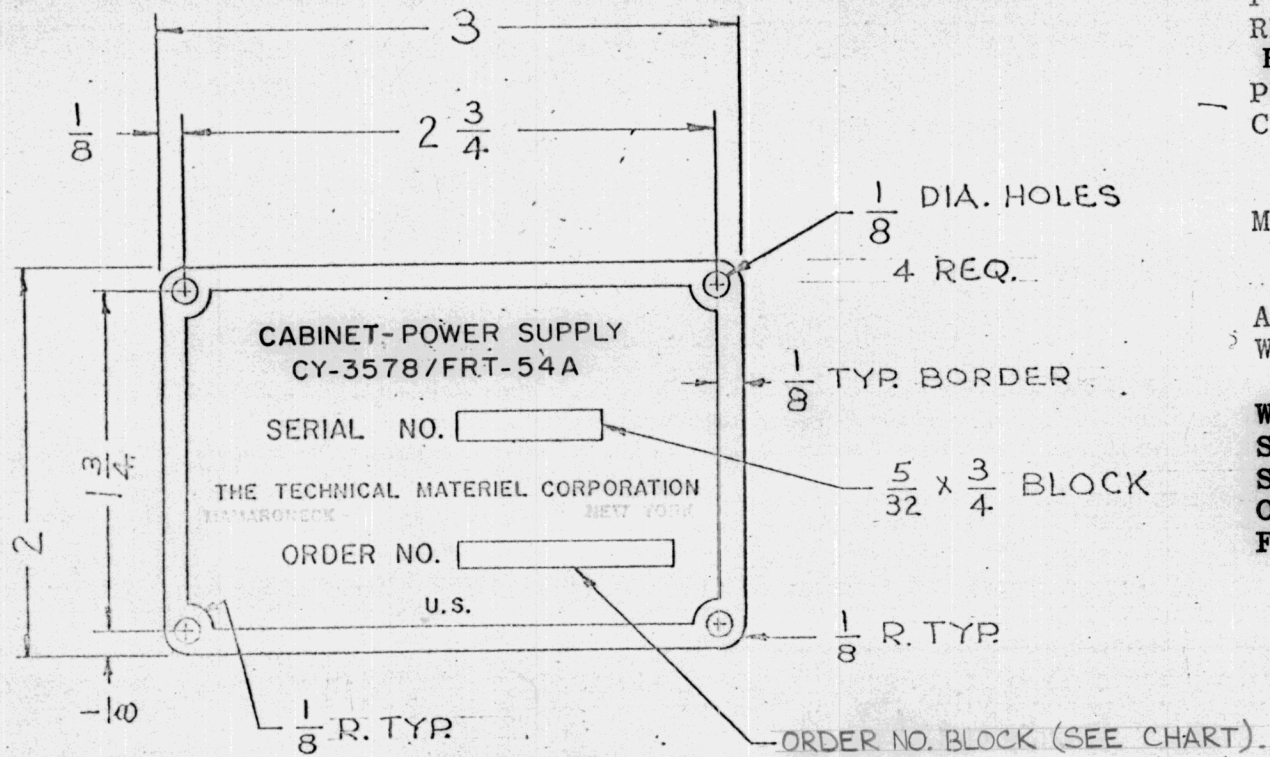

FINISH:
 REVERSE ETCH, ANODIZE ON LUSTERLESS
BLACK BACKGROUND (TYPE 37038)
 PER FED. STD. NO. 595
 COLORLESS VARNISH PER MIL-V-6894

MINIMUM LETTER SIZE - 3/64 HIGH

APPLICABLE ORDER AND SERIAL NUMBER
 WILL BE STEEL STAMPED BY T M C.

OR
 WHERE PURCHASING REQUIREMENT IS
 SUFFICIENTLY LARGE, ORDER NUMBER
 SHALL BE ETCHED BY VENDOR IN LIEU
 OF ORDER NUMBER BLOCK (SEE CHART
 FOR PROPER NUMBER).

TMC NO.	ORDER NO. BLOCK	ORDER NO. (ETCHED BY VENDOR)
NP-471-1	5/32 X 1-1/8 Block	No Order Number
NP-471-2	No Block	18002-PP-62

NAMEPLATE TO BE IN ACCORDANCE WITH
 MIL-STD-130 AND MIL-M-13231A
 (REF: SIGNAL CORPS)

REQ.	ITEM	PART NO.	DESCRIPTION	SYMBOL
		.032	THE TECHNICAL MATERIEL CORP. MAMARONECK, NEW YORK	
		STOCK SIZE		
A	MAMIK, N.Y. DELETED ON PICTORIAL	72862 11955	ALUMINUM	NAMEPLATE, IDENTIFICATION
			MATERIAL	MODEL AX-263
SYM	DESCRIPTION	DATE	CH. NO.	DRAFTS
			CHECKER	ENG. APP.
UNLESS OTHERWISE SPECIFIED:		SCALE:		
DIMENSIONS ARE IN INCHES		MAXIMUM ALLOWABLE TOLERANCES HAVE BEEN DETERMINED AND ANY DEVIATIONS WILL BE CAUSE FOR REJECTION. REMOVE ALL BURRS AND SHARP EDGES		
TOLERANCES ON				
FRAC. ± 1/64 DEC. ± .005 ANGLES ± 1/2°				
		250	φ.S	Joe
		TYPE & TEMPER	HEATTREAT. SPEC.	DRAWN
		SEE NOTE		CHECKED
		FINISH & SPEC. NO.	ELEC. DES. APP.	MECH. DES. APP.
				LG
				NP-471A

THE CONTENTS OF THIS DRAWING ARE THE EXCLUSIVE PROPERTY OF THE TECHNICAL MATERIEL CORP. ITS UNAUTHORIZED USE OR REPRODUCTION IN WHOLE OR IN PART IS STRICTLY FORBIDDEN.

REQ. PER UNIT

1

AK-100 (ISK)

USED ON

MODEL

ASS'Y. NO.

DATE

5-3-62

NP-472 | A

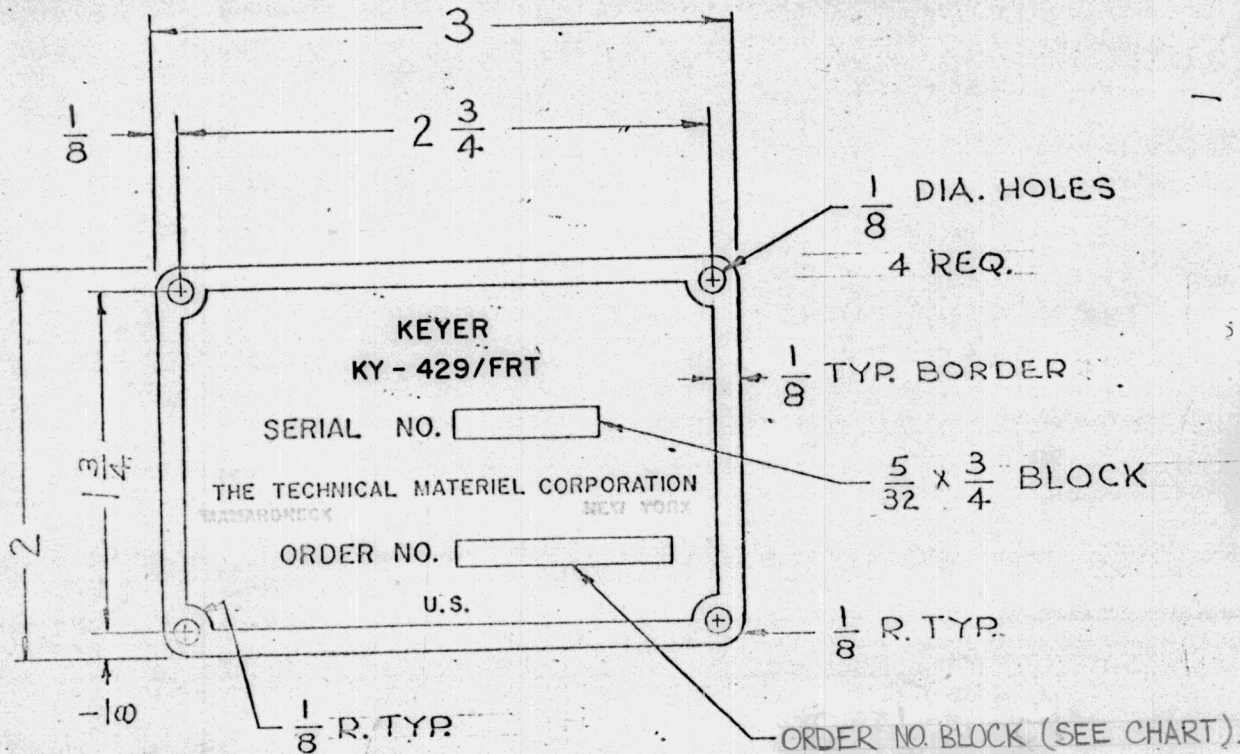

FINISH:
REVERSE ETCH, ANODIZE ON LUSTERLESS
BLACK BACKGROUND (TYPE 37038)
PER FED. STD. NO. 595
COLORLESS VARNISH PER MIL-V-6894

MINIMUM LETTER SIZE - 3/64 HIGH

APPLICABLE ORDER AND SERIAL NUMBER
WILL BE STEEL STAMPED BY T M C.

OR
WHERE PURCHASING REQUIREMENT IS
SUFFICIENTLY LARGE, ORDER NUMBER
SHALL BE ETCHED BY VENDOR IN LIEU
OF ORDER NUMBER BLOCK (SEE CHART
FOR PROPER NUMBER).

TMC NO.	ORDER NO. BLOCK	ORDER NO. (ETCHED BY VENDOR)
NP-472-1	5/32 X 1-1/8 Block	No Order Number
NP-472-2	No Block	18002-PP-62

NAMEPLATE TO BE IN ACCORDANCE WITH
MIL-STD-130 AND MIL-M-13231A
(REF: SIGNAL CORPS)

REQ.	ITEM	PART NO.	DESCRIPTION	SYMBOL
		.032	THE TECHNICAL MATERIEL CORP. MAMARONECK, NEW YORK	
		STOCK SIZE		
		ALUMINUM	NAMEPLATE, IDENTIFICATION	
		MATERIAL	MODEL AK-100	
A	MAM'K, N.Y. DELETED ON PICTORIAL	1/8 64 11955	G.P.S.	file
SYM	DESCRIPTION	DATE CH. NO. DRAFTS CHECKER ENG. APP.	DRAWN	CHECKED
UNLESS OTHERWISE SPECIFIED: DIMENSIONS ARE IN INCHES TOLERANCES ON FRAC. ± 1/64 DEC. ± .005 ANGLES ± 1/2°		SCALE: MAXIMUM ALLOWABLE TOLERANCES HAVE BEEN DETERMINED AND ANY DEVIATIONS WILL BE CAUSE FOR REJECTION. REMOVE ALL BURRS AND SHARP EDGES	FINAL APPROVAL	
		250		
		TYPE & TEMPER		
		HEATTREAT. SPEC.		
		FINISH & SPEC. NO.		
			ELEC. DES. APP.	MECH. DES. APP.
				NP-472 A

THE CONTENTS OF THIS DRAWING ARE THE EXCLUSIVE PROPERTY OF THE TECHNICAL MATERIEL CORP. ITS UNAUTHORIZED USE OR REPRODUCTION IN WHOLE OR IN PART IS STRICTLY FORBIDDEN.

REQ. PER UNIT
1

MODEL
AX-103

USED ON

ASS'Y. NO.
GPT-10K

DATE
5-3-62

NP-473 | A

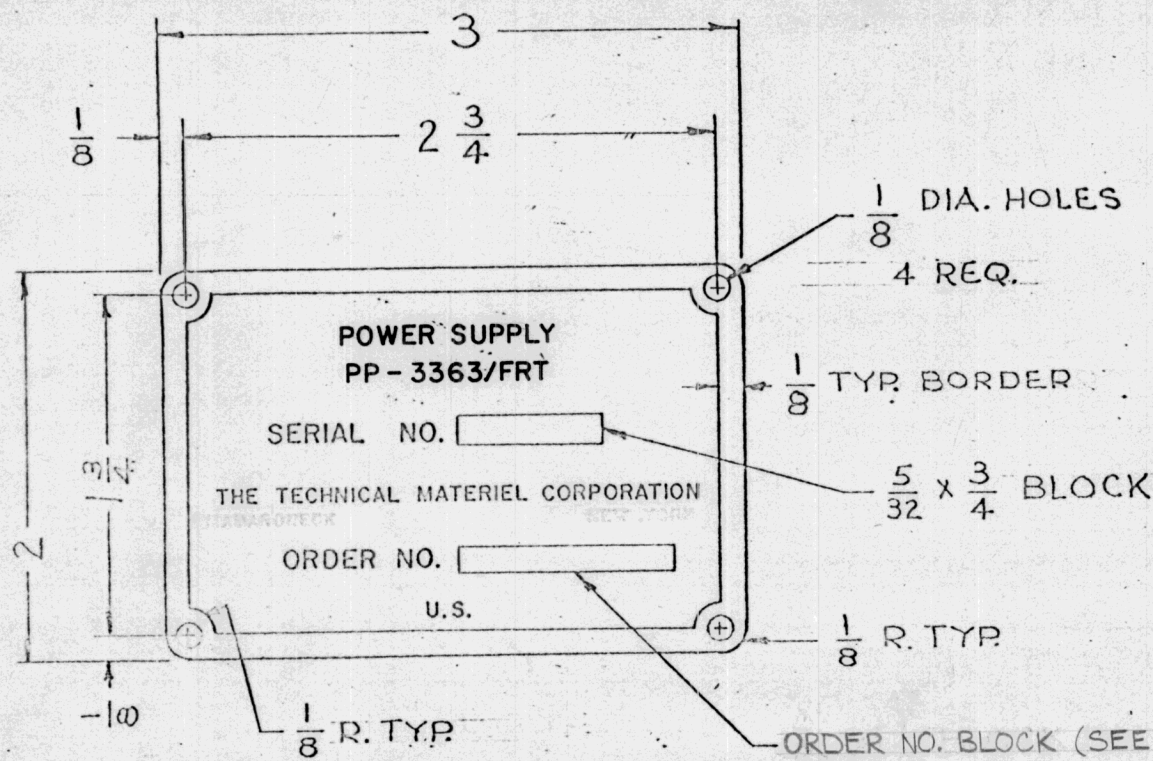

FINISH:
REVERSE ETCH, ANODIZE ON LUSTERLESS
BLACK BACKGROUND (TYPE 37038)
PER FED. STD. NO. 595
COLORLESS VARNISH PER MIL-V-6894

MINIMUM LETTER SIZE - 3/64 HIGH

APPLICABLE ORDER AND SERIAL NUMBER
WILL BE STEEL STAMPED BY T M C.

OR
WHERE PURCHASING REQUIREMENT IS
SUFFICIENTLY LARGE, ORDER NUMBER
SHALL BE ETCHED BY VENDOR IN LIEU
OF ORDER NUMBER BLOCK (SEE CHART
FOR PROPER NUMBER).

TMC NO.	ORDER NO. BLOCK	ORDER NO. (ETCHED BY VENDOR)
NP-473-1	5/32 X 1-1/8 Block	No Order Number
NP-473-2	No Block	18002-PP-62

NAMEPLATE TO BE IN ACCORDANCE WITH
MIL-STD-130 AND MIL-M-13231A
(REF: SIGNAL CORPS)

REQ.	ITEM	PART NO.	DESCRIPTION	SYMBOL					
		.032	THE TECHNICAL MATERIEL CORP. MAMARONECK, NEW YORK						
		ALUMINUM	NAMEPLATE, IDENTIFICATION						
			MODEL AX-103						
A	MAM'K, N.Y. DELETED ON PICTORIAL	72864 11955							
SYM	DESCRIPTION	DATE	CH. NO.	DRAFTS	CHECKER	ENG. APP.			
UNLESS OTHERWISE SPECIFIED: DIMENSIONS ARE IN INCHES TOLERANCES ON FRAC. ± 1/64 DEC. ± .005 ANGLES ± 1/2°		SCALE: MAXIMUM ALLOWABLE TOLERANCES HAVE BEEN DETERMINED AND ANY DEVIATIONS WILL BE CAUSE FOR REJECTION. REMOVE ALL BURRS AND SHARP EDGES		250		G.P.S.		DRAWN CHECKED FINAL APPROVAL	
				SEE NOTE		46		NP-473 A	
				FINISH & SPEC. NO.		ELEC. DES. APP. MECH. DES. APP.			

THE CONTENTS OF THIS DRAWING ARE THE EXCLUSIVE PROPERTY OF THE TECHNICAL MATERIEL CORP. ITS UNAUTHORIZED USE OR REPRODUCTION IN WHOLE OR IN PART IS STRICTLY FORBIDDEN.

REQ. PER UNIT

MODEL

USED ON

ASS'Y. NO.

DATE

1

AX-104

GPT-10K

5-3-62

NP-474 A

FINISH:
REVERSE ETCH, ANODIZE ON LUSTERLESS BLACK BACKGROUND (TYPE 37038) PER FED. STD. NO. 595
COLORLESS VARNISH PER MIL-V-6894

MINIMUM LETTER SIZE - 3/64 HIGH

APPLICABLE ORDER AND SERIAL NUMBER WILL BE STEEL STAMPED BY T M C.
OR

WHERE PURCHASING REQUIREMENT IS SUFFICIENTLY LARGE, ORDER NUMBER SHALL BE ETCHED BY VENDOR IN LIEU OF ORDER NUMBER BLOCK (SEE CHART FOR PROPER NUMBER).

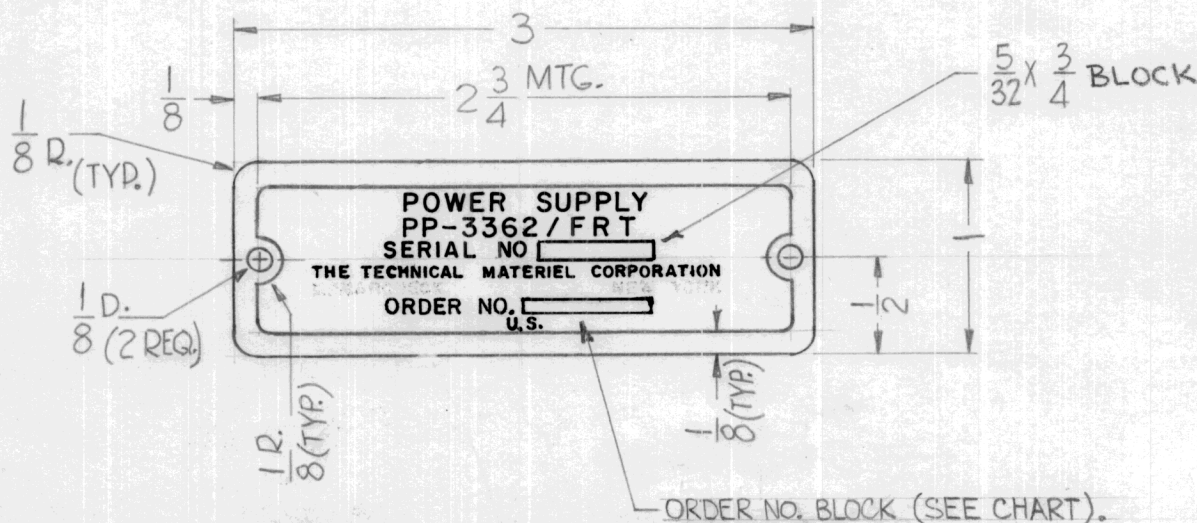

TMC NO.	ORDER NO. BLOCK	ORDER NO. (ETCHED BY VENDOR)
NP-474-1	5/32 X 1-1/8 Block	No Order Number
NP-474-2	No Block	18002-PP-62

NAMEPLATE TO BE IN ACCORDANCE WITH MIL-STD-130 AND MIL-M-13231A (REF: SIGNAL CORPS)

REQ.	ITEM	PART NO.	DESCRIPTION	SYMBOL	
			.032 THK.		
			STOCK SIZE		
A	MAM'K, N.Y. DELETED ON PICTORIAL	72862 11955	ALUMINUM	THE TECHNICAL MATERIEL CORP. MAMARONECK, NEW YORK	
SYM	DESCRIPTION	DATE	CH. NO.	DRAFTS	
			CHECKER	ENG. APP.	
UNLESS OTHERWISE SPECIFIED:		SCALE: DO NOT SCALE			
DIMENSIONS ARE IN INCHES		MAXIMUM ALLOWABLE TOLERANCES HAVE BEEN DETERMINED AND ANY DEVIATIONS WILL BE CAUSE FOR REJECTION.			
TOLERANCES ON		REMOVE ALL BURRS AND SHARP EDGES			
FRAC. ± 1/64 DEC. ± .005 ANGLES ± 1/2°					
		250		D. J. Man	
		SEE NOTE		Jude	
				9000	
				NP-474	
				A	

THE CONTENTS OF THIS DRAWING ARE THE EXCLUSIVE PROPERTY OF THE TECHNICAL MATERIEL CORP. ITS UNAUTHORIZED USE OR REPRODUCTION IN WHOLE OR IN PART IS STRICTLY FORBIDDEN.

REQ. PER UNIT	USED ON			NP-475 A
	MODEL	ASS'Y. NO.	DATE	
1	AP-104	GPT-401K	5-3-62	

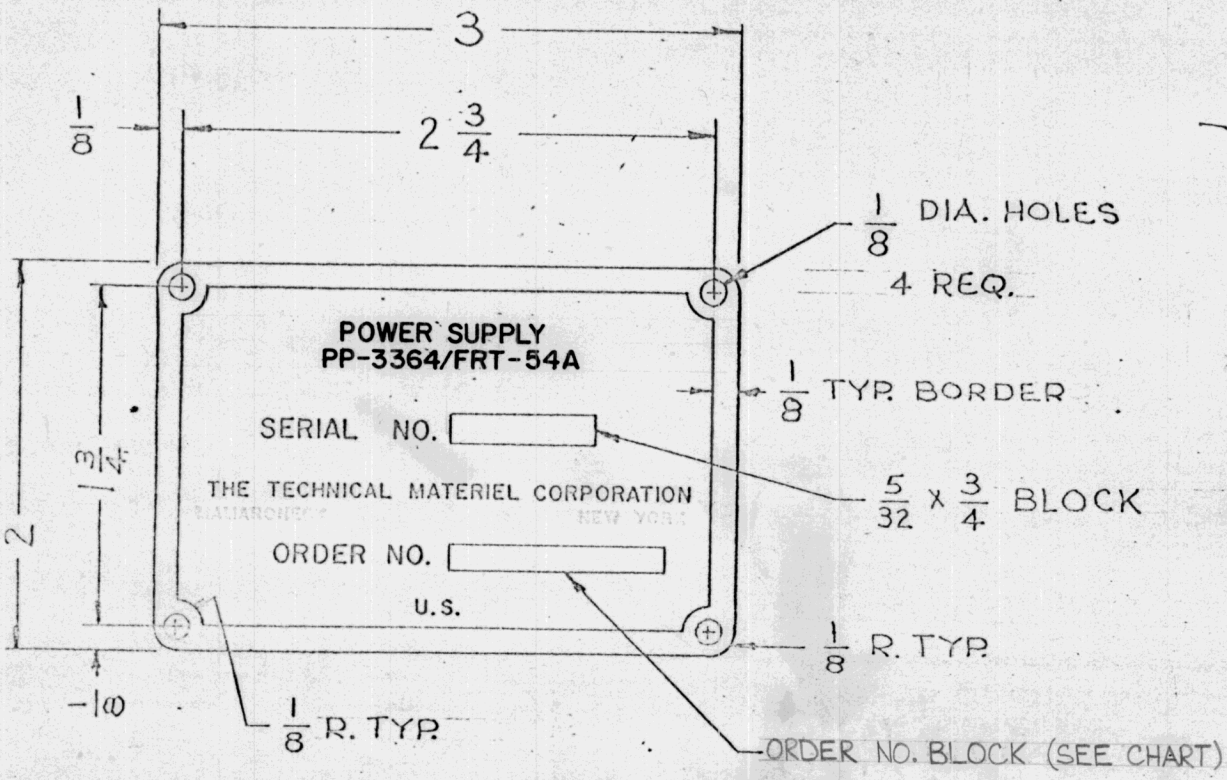

FINISH:
 REVERSE ETCH, ANODIZE ON LUSTERLESS
BLACK BACKGROUND (TYPE 37038)
 PER FED. STD. NO. 595
 COLORLESS VARNISH PER MIL-V-6894

MINIMUM LETTER SIZE - 3/64 HIGH

APPLICABLE ORDER AND SERIAL NUMBER
 WILL BE STEEL STAMPED BY T M C.
 OR

WHERE PURCHASING REQUIREMENT IS
 SUFFICIENTLY LARGE, ORDER NUMBER
 SHALL BE ETCHED BY VENDOR IN LIEU
 OF ORDER NUMBER BLOCK (SEE CHART
 FOR PROPER NUMBER).

TMC NO.	ORDER NO. BLOCK	ORDER NO. (ETCHED BY VENDOR)
NP-475-1	5/32 X 1-1/8 Block	No Order Number
NP-475-2	No Block	18002-PP-62

NAMEPLATE TO BE IN ACCORDANCE WITH
 MIL-STD-130 AND MIL-M-13231A
 (REF: SIGNAL CORPS)

							REQ.	ITEM	PART NO.	DESCRIPTION	SYMBOL		
									.032	THE TECHNICAL MATERIEL CORP. MAMARONECK, NEW YORK			
									ALUMINUM	NAMEPLATE, IDENTIFICATION			
									MATERIAL	MODEL AP-104			
									250	G.P.S.	<i>File</i>	<i>SEM</i>	
									TYPE & TEMPER	HEATTREAT. SPEC.	DRAWN	CHECKED	FINAL APPROVAL
									SEE NOTE		<i>16</i>	NP-475 A	
									FINISH & SPEC. NO.	ELEC. DES. APP.	MECH. DES. APP.		

UNLESS OTHERWISE SPECIFIED:
 DIMENSIONS ARE IN INCHES
 TOLERANCES ON
 FRAC. ± 1/64 DEC. ± .005 ANGLES ± 1/2°

SCALE:
 MAXIMUM ALLOWABLE TOLERANCES HAVE
 BEEN DETERMINED AND ANY DEVIATIONS
 WILL BE CAUSE FOR REJECTION.
 REMOVE ALL BURRS AND SHARP EDGES

THE CONTENTS OF THIS DRAWING ARE THE EXCLUSIVE PROPERTY OF THE TECHNICAL MATERIEL CORP. ITS UNAUTHORIZED USE OR REPRODUCTION IN WHOLE OR IN PART IS STRICTLY FORBIDDEN.

REQ. PER UNIT 1	USED ON		
	MODEL AP-105	ASS'Y. NO. GPT-40K	DATE 5-3-62

NP-476 | A

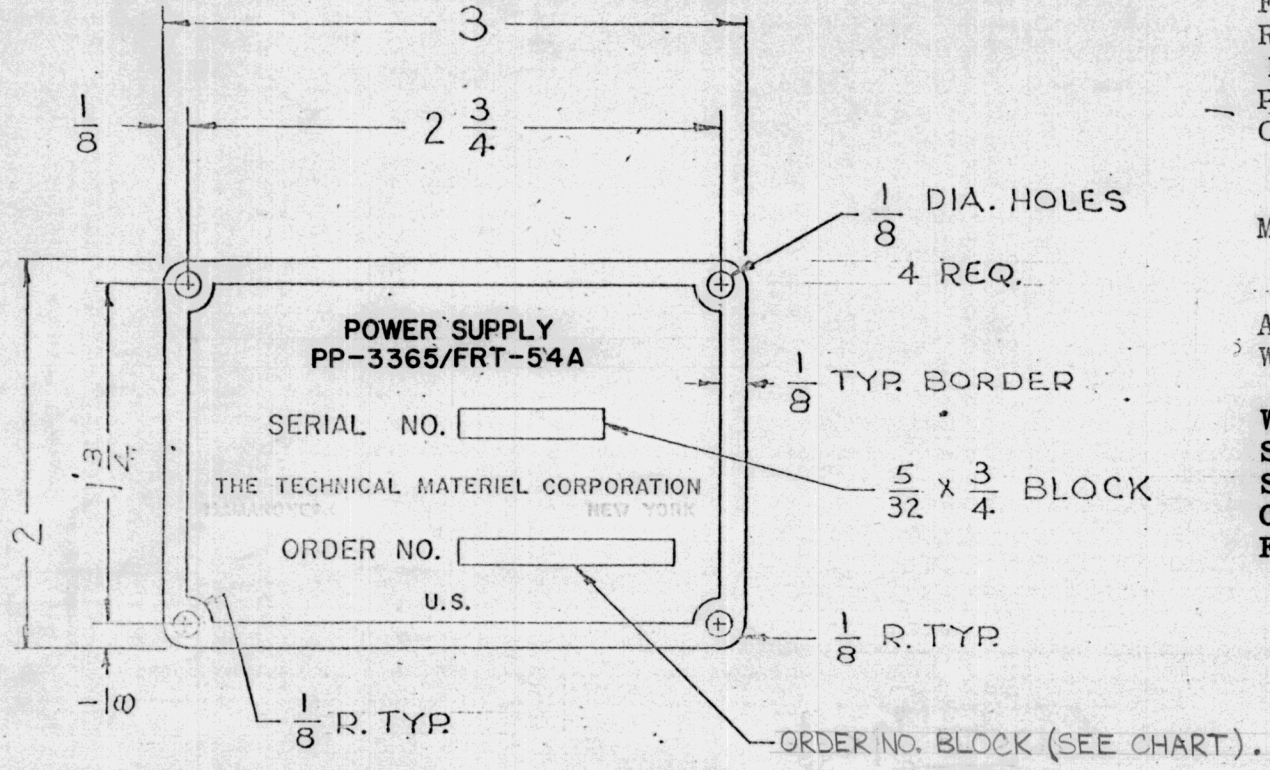

FINISH:
REVERSE ETCH, ANODIZE ON LUSTERLESS
BLACK BACKGROUND (TYPE 37038)
PER FED. STD. NO. 595
COLORLESS VARNISH PER MIL-V-6894

MINIMUM LETTER SIZE - 3/64 HIGH

APPLICABLE ORDER AND SERIAL NUMBER
WILL BE STEEL STAMPED BY T M C.

OR
WHERE PURCHASING REQUIREMENT IS
SUFFICIENTLY LARGE, ORDER NUMBER
SHALL BE ETCHED BY VENDOR IN LIEU
OF ORDER NUMBER BLOCK (SEE CHART
FOR PROPER NUMBER).

TMC NO.	ORDER NO. BLOCK	ORDER NO. (ETCHED BY VENDOR)
NP-476-1	5/32 X 1-1/8 Block	No Order Number
NP-476-2	No Block	18002-PP-62

NAMEPLATE TO BE IN ACCORDANCE WITH
MIL-STD-130 AND MIL-M-13231A
(REF: SIGNAL CORPS)

REQ.	ITEM	PART NO.	DESCRIPTION	SYMBOL
		.032	THE TECHNICAL MATERIEL CORP. MAMARONECK, NEW YORK	
		ALUMINUM	NAMEPLATE, IDENTIFICATION	
		MATERIAL	MODEL AP-105	
A	MAM'K, N.Y. DELETED ON PICTORIAL	728-64 11955	P.S.	FILE
SYM	DESCRIPTION	DATE	CH. NO.	DRAFTS
			CHECKER	ENG. APP.
UNLESS OTHERWISE SPECIFIED:		SCALE:		
DIMENSIONS ARE IN INCHES		MAXIMUM ALLOWABLE TOLERANCES HAVE BEEN DETERMINED AND ANY DEVIATIONS WILL BE CAUSE FOR REJECTION.		
TOLERANCES ON		REMOVE ALL BURRS AND SHARP EDGES		
FRAC. ± 1/64 DEC. ± .003 ANGLES ± 1/2°		2SO	TYPE & TEMPER	HEATTREAT. SPEC.
		SEE NOTE	DRAWN	CHECKED
		FINISH & SPEC. NO.	ELEC. DES. APP.	MECH. DES. APP.
				NP-476 A

THE CONTENTS OF THIS DRAWING ARE THE EXCLUSIVE PROPERTY OF THE TECHNICAL MATERIEL CORP. ITS UNAUTHORIZED USE OR REPRODUCTION IN WHOLE OR IN PART IS STRICTLY FORBIDDEN.

REQ. PER UNIT

MODEL
GPT-40K (E-3)

USED ON

ASS'Y. NO.
AX-358

DATE

NP-481

A

TMC NO.

ORDER NO. BLOCK

ORDER NO. (ETCHED BY VENDOR)

NP-481-1

5/32 x 1-1/8 Block

No Order Number

NP-481-2

No Block

18002-PP-62

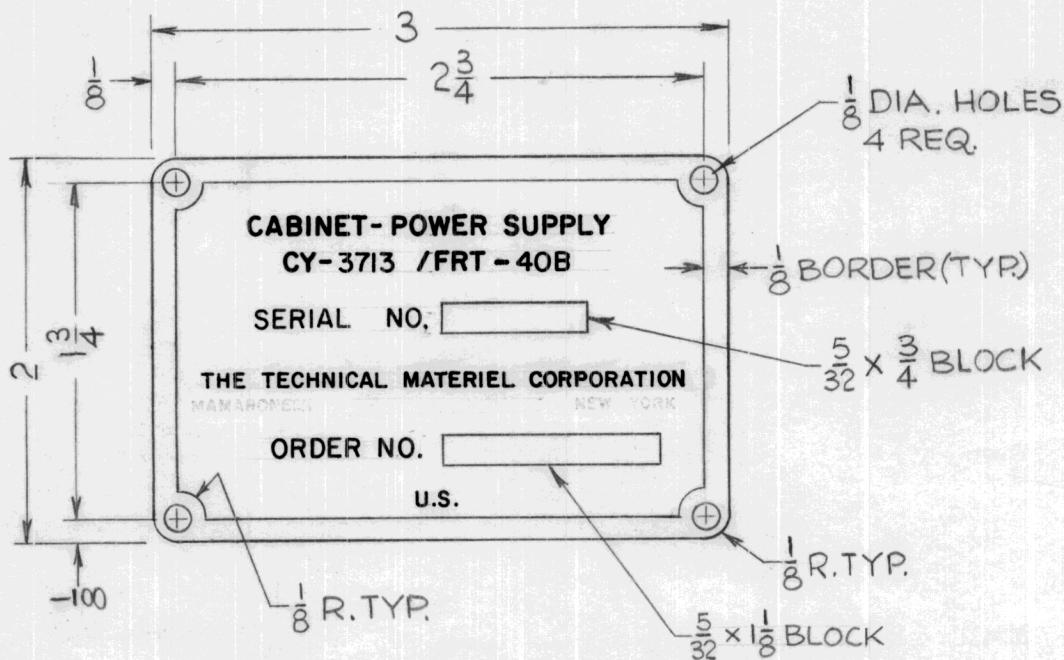

FINISH:
REVERSE ETCH, ANODIZE ON LUSTERLESS BLACK BACKGROUND (TYPE 37038) PER FED. STD. NO. 595
COLORLESS VARNISH PER MIL-V-6894

MINIMUM LETTER SIZE - 3/64 HIGH

APPLICABLE ORDER AND SERIAL NUMBER WILL BE STEEL STAMPED BY TMC OR

WHERE PURCHASING REQUIREMENT IS SUFFICIENTLY LARGE, ORDER NUMBER SHALL BE ETCHED BY VENDOR IN LIEU OF ORDER NUMBER BLOCK (SEE CHART FOR PROPER NUMBER).

NAMEPLATE TO BE IN ACCORDANCE WITH MIL-STD-130 AND MIL-M-13231A

(REF. SIGNAL CORPS)

REQ.	ITEM	PART NO.	DESCRIPTION			SYMBOL		
		.032 THK	THE TECHNICAL MATERIEL CORP.					
		STOCK SIZE	MAMARONECK, NEW YORK					
		ALUMINUM	NAMEPLATE IDENTIFICATION					
		MATERIAL						
A	MAM'K, N.Y. DELETED ON PICTORIAL	7-26-68 11955	DATE	CH. NO.	DRAFTS	CHECKER	ENG. APP.	
SYM	DESCRIPTION	DATE	CH. NO.	DRAFTS	CHECKER	ENG. APP.		
UNLESS OTHERWISE SPECIFIED:		SCALE:						
DIMENSIONS ARE IN INCHES		MAXIMUM ALLOWABLE TOLERANCES HAVE BEEN DETERMINED AND ANY DEVIATIONS WILL BE CAUSE FOR REJECTION.						
TOLERANCES ON		REMOVE ALL BURRS AND SHARP EDGES						
FRAC. ± 1/64 DEC. ± .005 ANGLES ± 1/2°								
		250	V.R.R.		DRAWN		CHECKED	FINAL APPROVAL
		SEE NOTE						NP-481
		FINISH & SPEC. NO.	ELEC. DES. APP.		MECH. DES. APP.			A

THE CONTENTS OF THIS DRAWING ARE THE EXCLUSIVE PROPERTY OF THE TECHNICAL MATERIEL CORP. ITS UNAUTHORIZED USE OR REPRDUCTION IN WHOLE OR IN PART IS STRICTLY FORBIDDEN.

REQ. PER UNIT	USED ON			NP-482	A
	MODEL	ASS'Y. NO.	DATE		
	GPT-10K(R)				

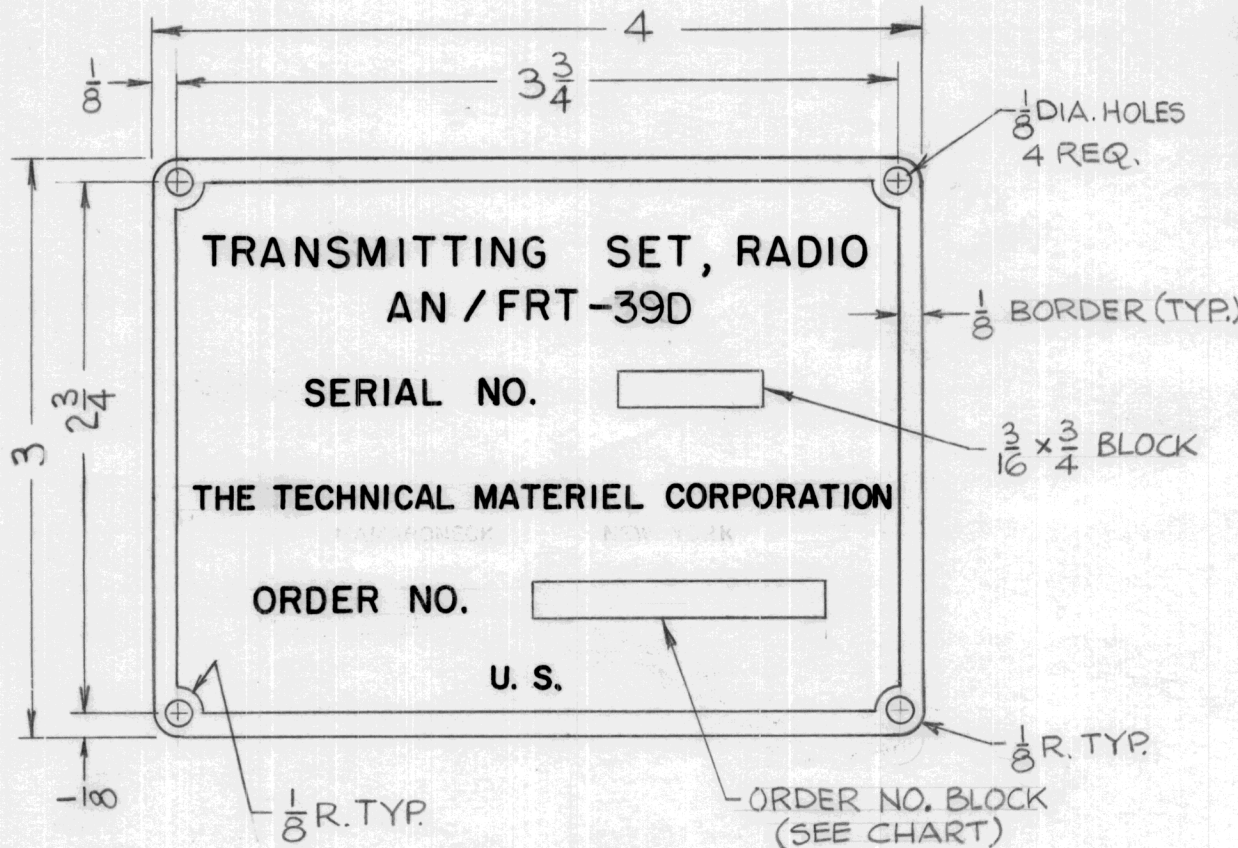

TMC PART NO.	ORDER NO. BLOCK	ORDER NO. (ETCHED BY VENDOR)
NP-482-1	3/16 x 1-1/2	No Order No.
NP-482-2	No Block	18002-PP-62

FINISH:
 REVERSE ETCH, ANODIZE ON LUSTERLESS BLACK BACKGROUND (TYPE 37038) PER FED. STD. NO. 595
 COLORLESS VARNISH PER MIL-V-6894

MINIMUM LETTER SIZE - 3/64 HIGH

APPLICABLE ORDER AND SERIAL NUMBER WILL BE STEEL STAMPED BY TMC
 OR

WHERE PURCHASING REQUIREMENT IS SUFFICIENTLY LARGE, ORDER NUMBER SHALL BE ETCHED BY VENDOR IN LIEU OF ORDER NUMBER BLOCK (SEE CHART FOR PROPER NUMBER).

NAMEPLATE TO BE IN ACCORDANCE WITH MIL-STD-130 AND MIL-M-13231A (REF. SIGNAL CORPS)

SYM	DESCRIPTION	DATE	CH. NO.	DRAFTS	CHECKER	ENG. APP.	REQ.	ITEM	PART NO.	DESCRIPTION	SYMBOL	
									.032 THK.	THE TECHNICAL MATERIEL CORP. MAMARONECK, NEW YORK		
									STOCK SIZE			
									ALUMINUM		NAMEPLATE, IDENTIFICATION	
									MATERIAL			
A	MAM'R, N.Y. DELETED ON PICTORIAL	7-28-64	1955						250	V.R.R.		
									TYPE & TEMPER	DRAWN	CHECKED	FINAL APPROVAL
									SEE NOTE			NP-482
									FINISH & SPEC. NO.	ELEC. DES. APP.	MECH. DES. APP.	A

UNLESS OTHERWISE SPECIFIED:
 DIMENSIONS ARE IN INCHES
 TOLERANCES ON
 FRAC. ± 1/64 DEC. ± .005 ANGLES ± 1/2°

SCALE:
 MAXIMUM ALLOWABLE TOLERANCES HAVE BEEN DETERMINED AND ANY DEVIATIONS WILL BE CAUSE FOR REJECTION.
 REMOVE ALL BURRS AND SHARP EDGES

THE CONTENTS OF THIS DRAWING ARE THE EXCLUSIVE PROPERTY OF THE TECHNICAL MATERIEL CORP. ITS UNAUTHORIZED USE OR REPRODUCTION IN WHOLE OR IN PART IS STRICTLY FORBIDDEN.

REQ. PER UNIT

AX-357

USED ON

MODEL

ASS'Y. NO.

DATE

GPT-10K(R)

5-23-62

NP-486

A

TMC NO.

NP-480-1

NP-480-2

ORDER NO. BLOCK

5/32 x 1-1/8

No Block

ORDER NO.

(ETCHED BY VENDOR)

No Order Number

18002-PP-62

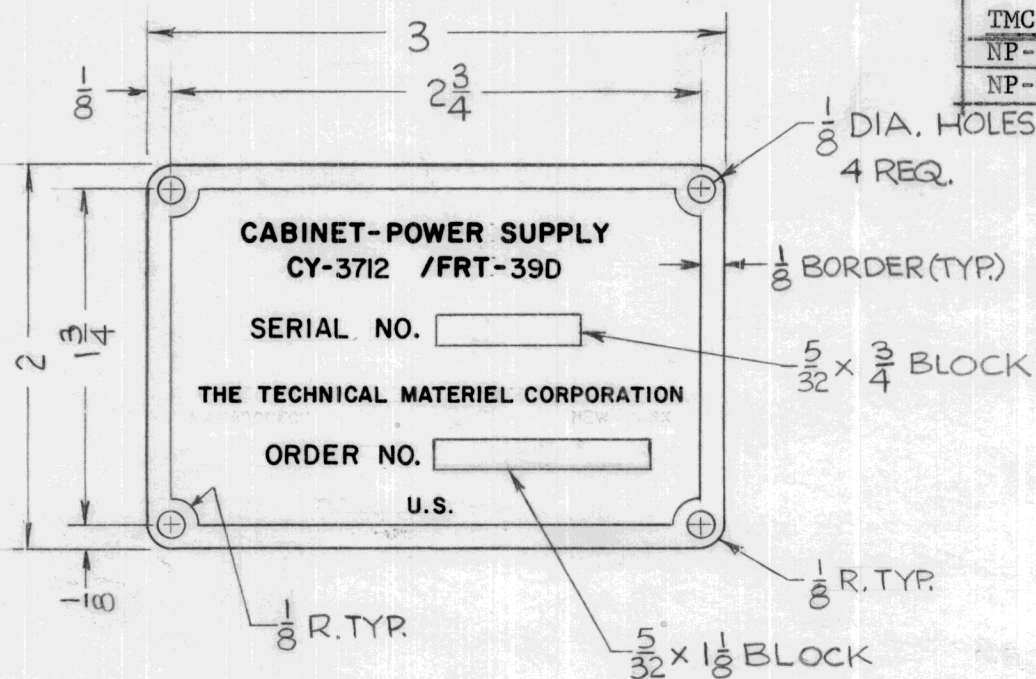

FINISH:
 REVERSE ETCH, ANODIZE ON LUSTERLESS
 BLACK BACKGROUND (TYPE 37038)
 PER FED. STD. NO. 595
 COLORLESS VARNISH PER MIL-V-6894

MINIMUM LETTER SIZE - 3/64 HIGH

APPLICABLE ORDER AND SERIAL NUMBER
 WILL BE STEEL STAMPED BY TMC
 OR

WHERE PURCHASING REQUIREMENT IS
 SUFFICIENTLY LARGE, ORDER NUMBER
 SHALL BE ETCHED BY VENDOR IN LIEU
 OF ORDER NUMBER BLOCK (SEE CHART
 FOR PROPER NUMBER).

NAMEPLATE TO BE IN ACCORDANCE WITH MIL-STD-130 AND
 MIL-M-13231A

(REF. SIGNAL CORPS)

REQ.	ITEM	PART NO.	DESCRIPTION			SYMBOL		
		.032 THK	THE TECHNICAL MATERIEL CORP.					
		STOCK SIZE	MAMARONECK, NEW YORK					
		ALUMINUM	NAMEPLATE IDENTIFICATION					
		MATERIAL						
A		MAM'R, N.Y. DELETED ON PICTORIAL	DATE	CH. NO.	DRAFTS	CHECKER	ENG. APP.	
			2464	11955				
SYM		DESCRIPTION	DATE	CH. NO.	DRAFTS	CHECKER	ENG. APP.	
		UNLESS OTHERWISE SPECIFIED: DIMENSIONS ARE IN INCHES. TOLERANCES ON FRAC. ± 1/64 DEC. ± .005 ANGLES ± 1/2°	SCALE: MAXIMUM ALLOWABLE TOLERANCES HAVE BEEN DETERMINED AND ANY DEVIATIONS WILL BE CAUSE FOR REJECTION. REMOVE ALL BURRS AND SHARP EDGES					
		250				V.R.R.		
		TYPE & TEMPER	HEATTREAT.SPEC.			DRAWN	CHECKED	FINAL APPROVAL
		SEE NOTE						
		FINISH & SPEC. NO.				ELEC. DES. APP.	MECH. DES. APP.	
								NP-486
								A

THE CONTENTS OF THIS DRAWING ARE THE EXCLUSIVE PROPERTY OF THE TECHNICAL MATERIEL CORP. ITS UNAUTHORIZED USE OR REPRODUCTION IN WHOLE OR IN PART IS STRICTLY FORBIDDEN.

REQ. PER UNIT	USED ON		
	MODEL	ASS'Y. NO.	DATE
1	SW-305	A-2456	
1	SW-306	A-2457	
1	SW-307	A-2458	
1	SW-308	A-2459	
1	SW-309	A-2460	
1	SW-310	A-2461	
1	SW-311	A-2462	
1	SW-312	A-2463	
	SW-317	A-2519	
	SW-318	A-2520	

NP-488 A

TMC INSIGNIA (NP-493)



NOTES:

- BLACK MATTE BACKGROUND CLEAR ANODIZED LETTERING, BORDER & TMC INSIGNIA.
- PRESSURE SENSITIVE ADHESIVE BACKING W/ ZIP OFF LINER
- APPLICATION: PAINTED SURFACE.

REQ.	ITEM	PART NO.	DESCRIPTION				SYMBOL
		.003 TO .005	THE TECHNICAL MATERIEL CORP.				
		STOCK SIZE	MAMARONECK, NEW YORK				
A	ADD. NOTE TO CHT.	2-19-69	19238	GE	FB	ALUMINUM FOIL	NAMEPLATE
SYM	DESCRIPTION	DATE	CH. NO.	DRAFTS	CHECKER	ENG. APP.	TMC IDENTIFICATION
UNLESS OTHERWISE SPECIFIED:		SCALE: _____		DRAWN		CHECKED	FINAL APPROVAL
DIMENSIONS ARE IN INCHES		MAXIMUM ALLOWABLE TOLERANCES HAVE BEEN DETERMINED AND ANY DEVIATIONS WILL BE CAUSE FOR REJECTION.		SEE NOTE			
TOLERANCES ON		REMOVE ALL BURRS AND SHARP EDGES		FINISH & SPEC. NO.		ELEC. DES. APP.	MECH. DES. APP.
FRAC. ± 1/64 DEC. ± .005 ANGLES ± 1/2°							NP-488 A

THE CONTENTS OF THIS DRAWING ARE THE EXCLUSIVE PROPERTY OF THE TECHNICAL MATERIEL CORP. ITS UNAUTHORIZED USE OR REPRODUCTION IN WHOLE OR IN PART IS STRICTLY FORBIDDEN.

REQ. PER UNIT	USED ON		
	TMC PART NO.	MODEL INSERT	ASS'Y NO.
1	NP 489-1	FLANGE	A 2456
1	NP 489-2	SW 305	A 2457
1	NP 489-3	SW 306	A 2458
1	NP 489-4	SW 307	A 2459
1	NP 489-5	SW 308	A 4334
1	NP 489-6	SW 409	A 4460
1	NP 489-7	SW 421	

NP 489 B

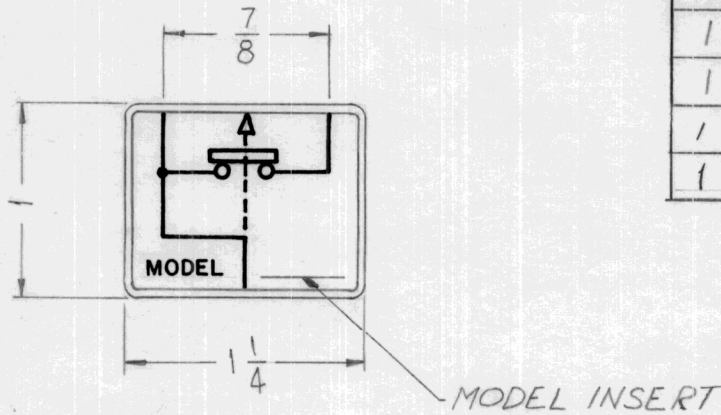

NOTES:

- ALL LETTERING, SYMBOLS & BORDER TO BE BLACK.
- BACKGROUND TO BE ALUMINUM CLEAR ANODIZED.
- ADHESIVE BACKING, WATER SOLVENT.
- APPLICATION: PAINTED SURFACE.

REQ.	ITEM	PART NO.	DESCRIPTION	SYMBOL							
		.003 TO .005	THE TECHNICAL MATERIEL CORP. MAMARONECK, NEW YORK								
		STOCK SIZE									
B	NP489-7 ADDED	53166 16290 HLA	ALUMINUM FOIL								
A	NP 489-6 ADDED	9/29/63 14847 H.V.V.	SCHEMATIC, DIAGRAM								
SYM	DESCRIPTION	DATE	CH. NO.	DRAFTS	CHECKER	ENG. APP.	MATERIAL	SWITCH JACK, ASSEMBLY			
UNLESS OTHERWISE SPECIFIED: DIMENSIONS ARE IN INCHES TOLERANCES ON FRAC. ± 1/64 DEC. ± .005 ANGLES ± 1/2°		SCALE: DO NOT SCALE		MAXIMUM ALLOWABLE TOLERANCES HAVE BEEN DETERMINED AND ANY DEVIATIONS WILL BE CAUSE FOR REJECTION. REMOVE ALL BURRS AND SHARP EDGES		TYPE & TEMPER		HEATTREAT. SPEC.	DRAWN	CHECKED	FINAL APPROVAL
						SEE NOTE		6/27/62		NP 489 B	
						FINISH & SPEC. NO.		ELEC. DES. APP.		MECH. DES. APP.	

STANDARD DRAWING

THE CONTENTS OF THIS DRAWING ARE THE EXCLUSIVE PROPERTY OF THE TECHNICAL MATERIEL CORP. ITS UNAUTHORIZED USE OR REPRODUCTION IN WHOLE OR IN PART IS STRICTLY FORBIDDEN.

REQ. PER UNIT	USED ON		
	TMC PART NO.	MODEL INSERT	ASSEMBLY NO.
	NP-490-1		
1	NP-490-2	SW 309	A 2460
1	NP 490-3	SW 310	A 2461
1	NP 490-4	SW 311	A 2462
1	NP 490-5	SW 312	A 2463
1	NP 490-6	SW 318	A 2520
1	NP 490-7	SW 422	A 4451
1	NP 490-8	SW 458	A 4709
1	NP 490-9	SW 478	A 4747
1	NP 490-10	SW 477	A 5600

NP 490 E

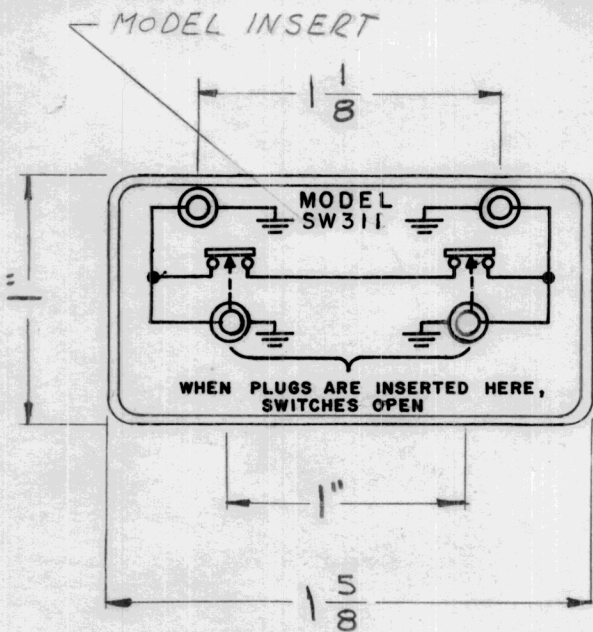

NOTE:

- ALL LETTERING, SYMBOLS & BORDER TO BE BLACK.
- BACKGROUND TO BE ALUMINUM CLEAR ANODIZED.
- ADHESIVE BACKING, WATER SOLVENT.
- APPLICATION: PAINTED SURFACE

SW 311

E	NP490-10 ADDED	9/27/76	21466	9/27/76		
D	NP490-9 ADDED	10/3/68	19072	CV		EFM
C	NP490-8 ADDED	1-31-68	18751	R.G.		EFM
B	CHG'D. GRD FR. INNER COND. TO OUT	8-2-66	16703	RME		
A	NP490-7 ADDED	5-31-66	16290	HLA		
SYM	DESCRIPTION	DATE	CH. NO.	DRAFTS	CHECKER	ENG. APP.

REQ.	ITEM	PART NO.	DESCRIPTION	SYMBOL
		.003 TO .005	THE TECHNICAL MATERIEL CORP. MAMARONECK, NEW YORK	
		STOCK SIZE		
		ALUMINUM FOIL		
		MATERIAL	SCHMATIC, DIAGRAM	
			SWITCH JACK, ASSEMBLY	
			G.S. 6-6-62	
		TYPE & TEMPER	DRAWN	CHECKED
		HEATTREAT. SPEC.		FINAL APPROVAL
		SEE NOTE		
		FINISH & SPEC. NO.	ELEC. DES. APP.	MECH. DES. APP.

UNLESS OTHERWISE SPECIFIED:
 DIMENSIONS ARE IN INCHES
 TOLERANCES ON
 FRAC. ± 1/64 DEC. ± .005 ANGLES ± 1/2°

SCALE: **DO NOT SCALE**
 MAXIMUM ALLOWABLE TOLERANCES HAVE BEEN DETERMINED AND ANY DEVIATIONS WILL BE CAUSE FOR REJECTION.
 REMOVE ALL BURRS AND SHARP EDGES

NP 490 E

THE CONTENTS OF THIS DRAWING ARE THE EXCLUSIVE PROPERTY OF THE TECHNICAL MATERIEL CORP. ITS UNAUTHORIZED USE OR REPRODUCTION IN WHOLE OR IN PART IS STRICTLY FORBIDDEN.

REQ. PER UNIT

MODEL

USED ON

ASS'Y. NO.

DATE

6-19-62

NP-492

C

STANDARD DRAWING

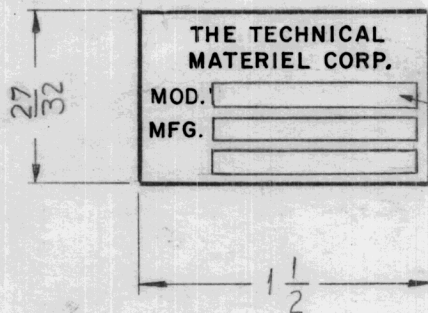

NOTE

- 1- ALUMINUM COLORED GOTHIC LETTERING, 8 BLOCKS, 10 POINT SPARTAN HEAVY.
- 2- BACKGROUND TO BE BLACK.
- 3- TO BE SUPPLIED WITH PRESSURE SENSITIVE ADHESIVE BACKING AND ZIP-OFF LINER 1/4 WIDER THAN NAME DIMENSIONS AS LABELS PERASTRIP REMOVAL.
- 4- APPROXIMATELY 15 LABELS PER STRIP (NOT TO BE CUT)

REQ.	ITEM	PART NO.	SYMBOL			DESCRIPTION	SYMBOL	
C	"NOT TO BE CUT" WAS "EA. LABEL PRE-CUT"	3-8-66 15933	WHD	QCB	9	THICKNESS, .003 MAX	THE TECHNICAL MATERIEL CORP. MAMARONECK, NEW YORK IDENTIFICATION, PLATE MFR.	
B	1/4 EXTENDED LINER DELETED NOTE REVISED (#3)	2/23/65 14652	L.V.	QCB	9	STOCK SIZE		
A	EXTENDED LINER ADDED	5-14-65 14033	CTC	JL		ALUMINUM FOIL		
SYM	DESCRIPTION	DATE	CH. NO.	DRAFTS	CHECKER	ENG. APP.	MATERIAL	
UNLESS OTHERWISE SPECIFIED:		SCALE:					ANODIZED	
DIMENSIONS ARE IN INCHES		MAXIMUM ALLOWABLE TOLERANCES HAVE BEEN DETERMINED AND ANY DEVIATIONS WILL BE CAUSE FOR REJECTION.					TYPE & TEMPER	HEATTREAT. SPEC.
TOLERANCES ON		REMOVE ALL BURRS AND SHARP EDGES					SEE NOTE	
FRAC. ± 1/64 DEC. ± .005 ANGLES ± 1/2°							FINISH & SPEC. NO.	
						DRAWN	CHECKED	FINAL APPROVAL
						S.G.	5/16/63	VPH
						ELEC. DES. APP.	MECH. DES. APP.	NP-492
								C

THE CONTENTS OF THIS DRAWING ARE THE EXCLUSIVE PROPERTY OF THE TECHNICAL MATERIEL CORP. ITS UNAUTHORIZED USE OR REPRODUCTION IN WHOLE OR IN PART IS STRICTLY FORBIDDEN.

REQ. PER UNIT

USED ON

MODEL

ASS'Y. NO.

DATE

SBT-1K-Q

7-3-62

NP-495

B

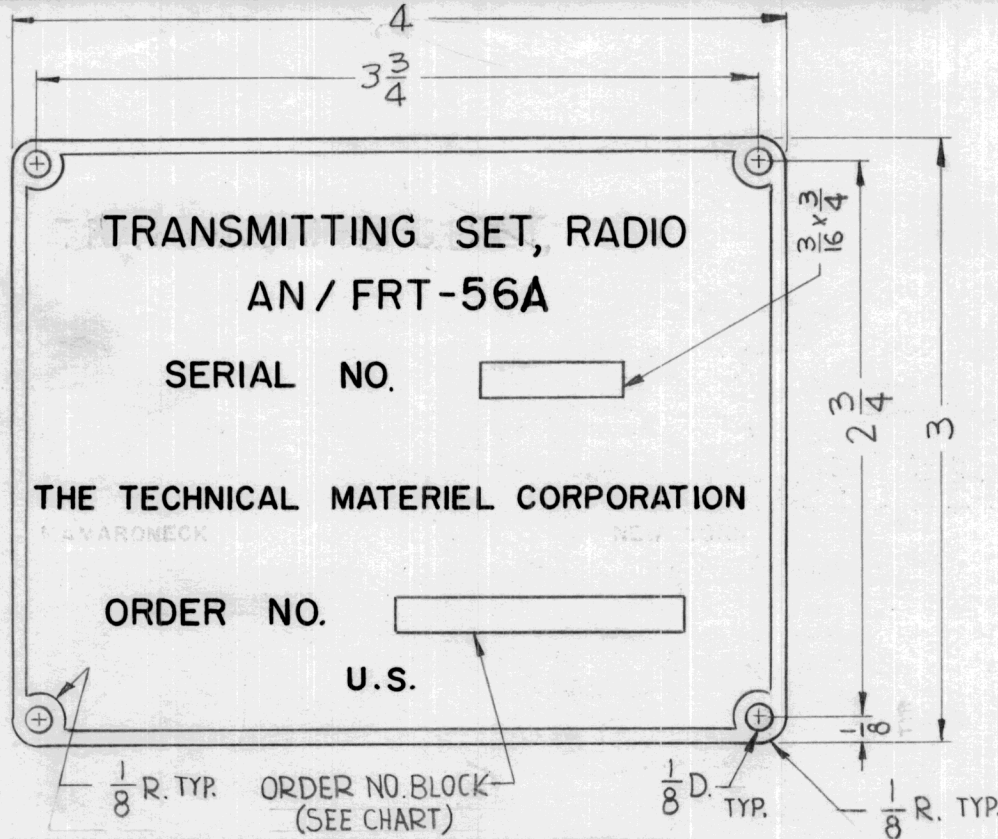

FINISH:
 REVERSE ETCH, ANODIZE ON LUSTERLESS BLACK BACKGROUND (TYPE 37038) PER FED. STD. NO. 595
 COLORLESS VARNISH PER MIL-V-6894

MINIMUM LETTER SIZE - 3/64 HIGH

APPLICABLE ORDER AND SERIAL NUMBER WILL BE STEEL STAMPED BY T M C OR

WHERE PURCHASING REQUIREMENT IS SUFFICIENTLY LARGE, ORDER NUMBER SHALL BE ETCHED BY VENDOR IN LIEU OF ORDER NUMBER BLOCK (SEE CHART FOR PROPER NUMBER).

TMC PART NO	ORDER NO. BLOCK	ORDER NO. (ETCHED BY VENDOR)
NP-495-1	3/16 X 1-1/2 Block	No Order Number
NP-495-2	No Block	

NAMEPLATE TO BE IN ACCORDANCE WITH MIL-STD-130 AND MIL-M-13231A (REF: SIGNAL CORPS)

REQ.	ITEM	PART NO.	DESCRIPTION	SYMBOL							
		032 THICK	THE TECHNICAL MATERIEL CORP. MAMARONECK, NEW YORK	NAMEPLATE, IDENTIFICATION							
		STOCK SIZE									
B	TYPE & TEMPER WAS 250. ADD SBT-1K Q3 TO TITLE. ADD A TO 56	11/3/66 17148 RME	ALUMINUM	SBT-1K Q3							
A	MAM'K, N.Y. DELETED ON PICTORIAL	7-28-64 11955									
SYM	DESCRIPTION	DATE	CH. NO.	DRAFTS	CHECKER	ENG. APP.	MATERIAL				
UNLESS OTHERWISE SPECIFIED: DIMENSIONS ARE IN INCHES TOLERANCES ON FRAC. ± 1/64 DEC. ± .005 ANGLES ± 1/2°		SCALE:		MAXIMUM ALLOWABLE TOLERANCES HAVE BEEN DETERMINED AND ANY DEVIATIONS WILL BE CAUSE FOR REJECTION. REMOVE ALL BURRS AND SHARP EDGES		5052-H32		Giannfilippo	Awe		
						SEE NOTE					
						FINISH & SPEC. NO.		ELEC. DES. APP.	MECH. DES. APP.	NP-495	B

CONTENTS OF THIS DRAWING ARE THE EXCLUSIVE PROPERTY OF THE TECHNICAL MATERIEL CORP. ITS UNAUTHORIZED USE OR REPRODUCTION IN WHOLE OR IN PART IS STRICTLY FORBIDDEN.

REQ. PER UNIT	USED ON		
	MODEL	ASS'Y. NO.	DATE
1	RAK-9Q	SBT-1KQ	7-3-62

NP-496 B

FINISH:
 REVERSE ETCH, ANODIZE ON LUSTERLESS BLACK BACKGROUND (TYPE 37038) PER FED. STD. NO. 595
 COLORLESS VARNISH PER MIL-V-6894

MINIMUM LETTER SIZE - 3/64 HIGH

APPLICABLE ORDER AND SERIAL NUMBER WILL BE STEEL STAMPED BY T M C OR WHERE PURCHASING REQUIREMENT IS SUFFICIENTLY LARGE, ORDER NUMBER SHALL BE ETCHED BY VENDOR IN LIEU OF ORDER NUMBER BLOCK (SEE CHART FOR PROPER NUMBER).

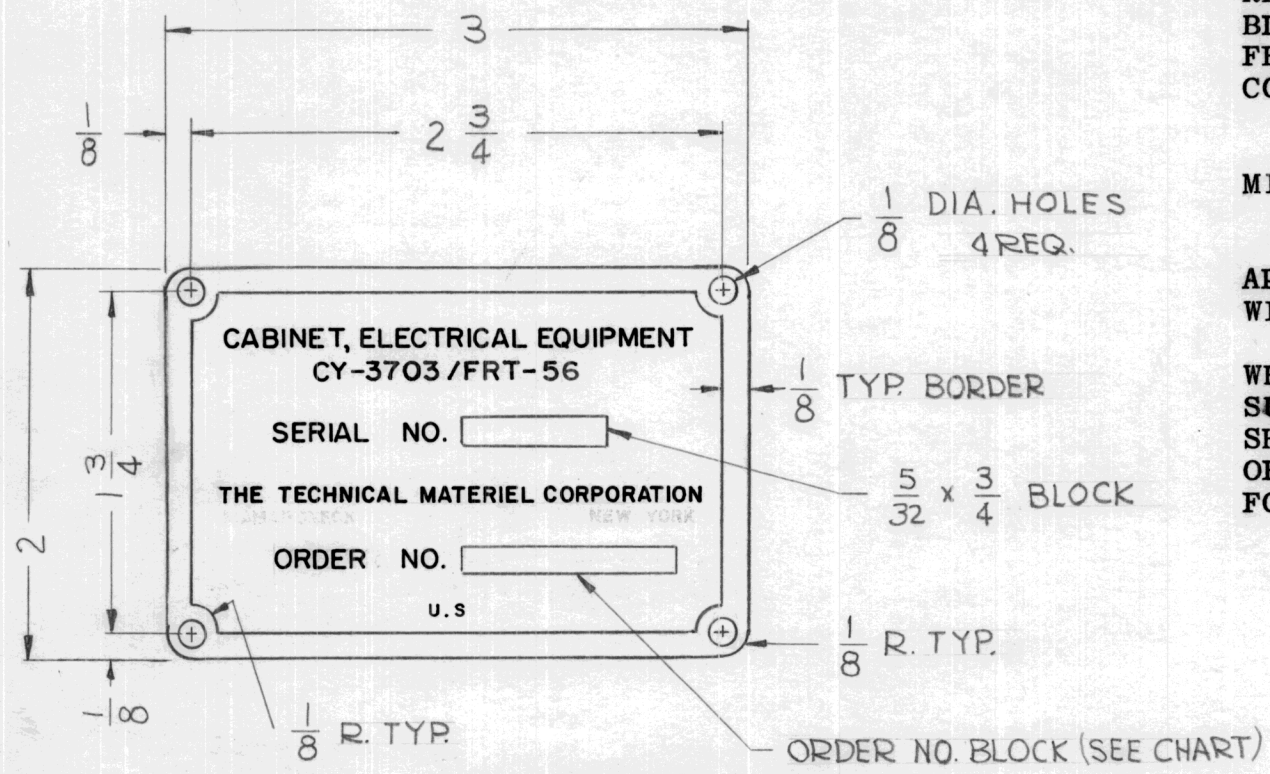

TMC NO.	ORDER NO. BLOCK	ORDER NO. (ETCHED BY VENDOR)
NP-496-1	5/32 X 1-1/8 Block	No Order Number
NP-496-2	No Block	

NAMEPLATE TO BE IN ACCORDANCE WITH MIL-STD-130 AND MIL-M-13231A (REF: SIGNAL CORPS)

REQ.	ITEM	PART NO.	DESCRIPTION	SYMBOL
		.032	THE TECHNICAL MATERIEL CORP. MAMARONECK, NEW YORK	NAMEPLATE IDENTIFICATION
		STOCK SIZE		
		ALUMINUM		
		MATERIAL		
		5052-H32	SRG	
		TYPE & TEMPER	DRAWN	CHECKED
		HEATTREAT. SPEC.		FINAL APPROVAL
		SEE NOTE		
		FINISH & SPEC. NO.	ELEC. DES. APP.	MECH. DES. APP.
				NP-496 B

UNLESS OTHERWISE SPECIFIED:
 DIMENSIONS ARE IN INCHES
 TOLERANCES ON
 FRAC. ± 1/64 DEC. ± .005 ANGLES ± 1/2°

SCALE:
 MAXIMUM ALLOWABLE TOLERANCES HAVE BEEN DETERMINED AND ANY DEVIATIONS WILL BE CAUSE FOR REJECTION.
 REMOVE ALL BURRS AND SHARP EDGES