

NF-103

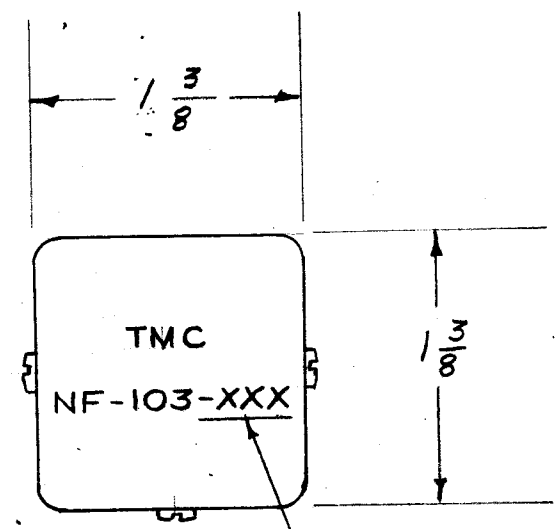
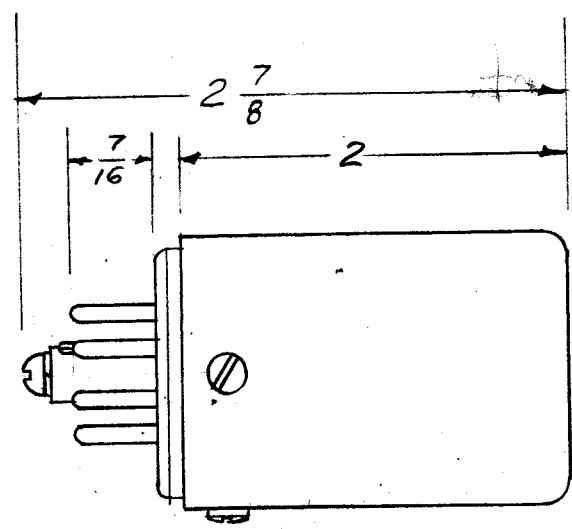
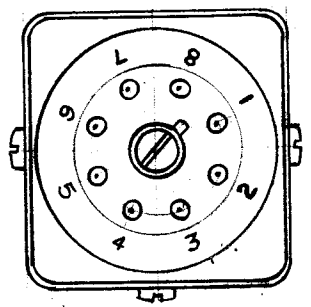
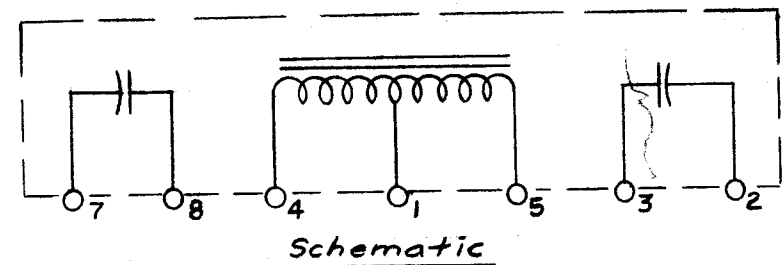

Frequency will be stamped here
(See Chart)

Dimensions for ref. only.
Etched Finish

TMC NO.	FREQ. (CPS)
NF-103-425	425
↑ -595	595
-765	765
-935	935
-1105	1105
-1275	1275
-1445	1445
-1615	1615
-1785	1785
-1955	1955
-2125	2125
-2295	2295
-2465	2465
-2635	2635
↓ -2805	2805
NF-103-2975	2975

NOTICE TO PERSONS RECEIVING THIS DRAWING

THE TECHNICAL MATERIEL CORPORATION claims proprietary right in the material disclosed hereon. This drawing is issued in confidence for engineering information only and may not be reproduced or used to manufacture anything shown hereon without permission from THE TECHNICAL MATERIEL CORPORATION to the user. This drawing is loaned for mutual assistance and is subject to recall at any time.

Property of:
THE TECHNICAL MATERIEL CORPORATION
MAMARONECK, NEW YORK

ISSUE	ITEM	CHANGED FROM	DATE	CH. NO.	DRAFTS	CHECKER	ENG. APP.
TOLERANCES			SCALE: 4A-1374				
DEC. DIM. ±			MAXIMUM ALLOWABLE TOLERANCES HAVE BEEN DETERMINED AND ANY DEVIATIONS WILL BE CAUSE FOR REJECTION.				
FRAC. DIM. ±			REMOVE ALL BURRS AND SHARP EDGES				
ANGULAR DIM. ±							

1	TTU					2-14-57
REQ. PER UNIT	MODEL	PROJECT NO.	ASSY. NO.	DATE		

REQ. ITEM	PART NO.	DESCRIPTION		SYMBOL
		THE TECHNICAL MATERIEL CORP. MAMARONECK, NEW YORK		
		FREQUENCY DETERMINING NETWORK		
		162-14-57	JAW	A.J.J.
			CHECKED	
				NF-103
			ELEC. DES. APP.	
			MESH. DES. APP.	