

REQ. PER UNIT	USED ON			MS-993	B
	MODEL	ASS'Y. NO.	DATE		
2	MSR-1	A-1377	12-27-56		

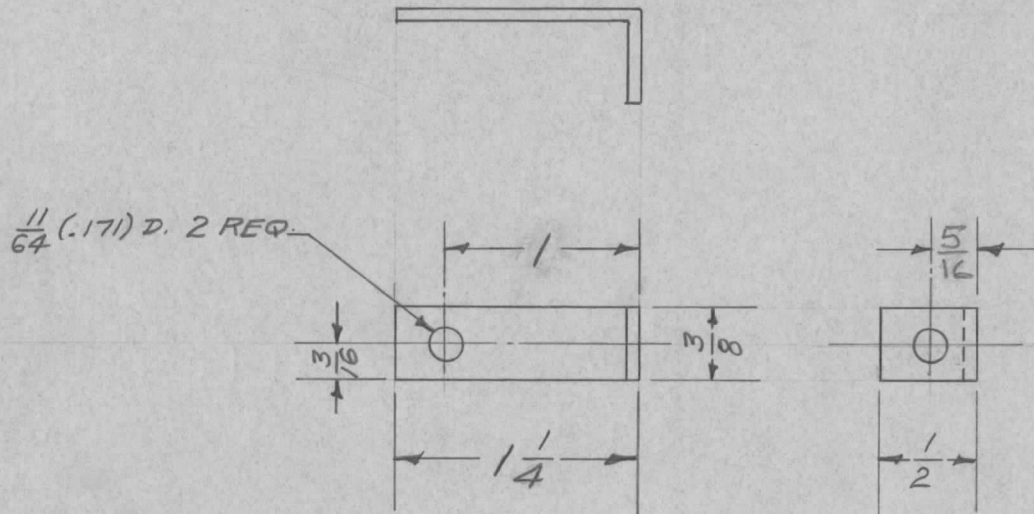

UNLESS OTHERWISE SPECIFIED  
DIMENSIONS ARE IN INCHES AND INCLUDE  
CHEMICALLY APPLIED OR PLATED FINISHES

DECIMALS	TOLERANCES	FRACTIONS
.X ± .05		± 1/64
.XX ± .01		ANGLES
.XXX ± .005		± 0° 30'

CUT HERE  
GUARANTEED  
2-66

REQ.	ITEM	PART NO.	DESCRIPTION				SYMBOL
		.064 THK.	THE TECHNICAL MATERIEL CORP.				
		STOCK SIZE	MAMARONECK, NEW YORK				
B	1	5404-IRIDITE WAS S101-CAUSTIC DIP	12-8 59	1001	SP	EMN	BRA BRACKET, LE,
A	1	5/16 WAS 1/4	8/27/58	1	file	MP	TERMINAL BOARD
ISSUE	ITEM	CHANGED FROM	DATE	CH. NO.	DRAFTS	CHECKER	ENG. APP.
TOLERANCES			SCALE:				
DEC. DIM. ±			MAXIMUM ALLOWABLE TOLERANCES HAVE				
FRAC. DIM. ±			BEEN DETERMINED AND ANY DEVIATIONS				
ANGULAR DIM. ±			WILL BE CAUSE FOR REJECTION.				
			REMOVE ALL BURRS AND SHARP EDGES				
5052-H32		—H—	12-27-56	file	MP		
TYPE & TEMPER		HEAT TREAT. SPEC.	DRAWN	CHECKED	FINAL APPROVAL		
S404 IRIDITE					MS-993 B		
FINISH & SPEC. NO.		ELEC. DES. APP.	MECH. DES. APP.				