

IF IT IS FOUND DESIRABLE TO CHANGE ANY TOLERANCE OR OTHER DETAIL SPECIFIED ON THIS DRAWING NOTIFY THE PURCHASER PROMPTLY.

MS-959 A

MAXIMUM ALLOWABLE TOLERANCES HAVE BEEN DETERMINED AND DEVIATIONS WILL BE CAUSE FOR REJECTION. REMOVE ALL BURRS AND SHARP EDGES

REQ PER UNIT	USED ON			
	MODEL	PROJECT NO.	ASS'Y. NO.	DATE
4	FX-150	459		8/15/56

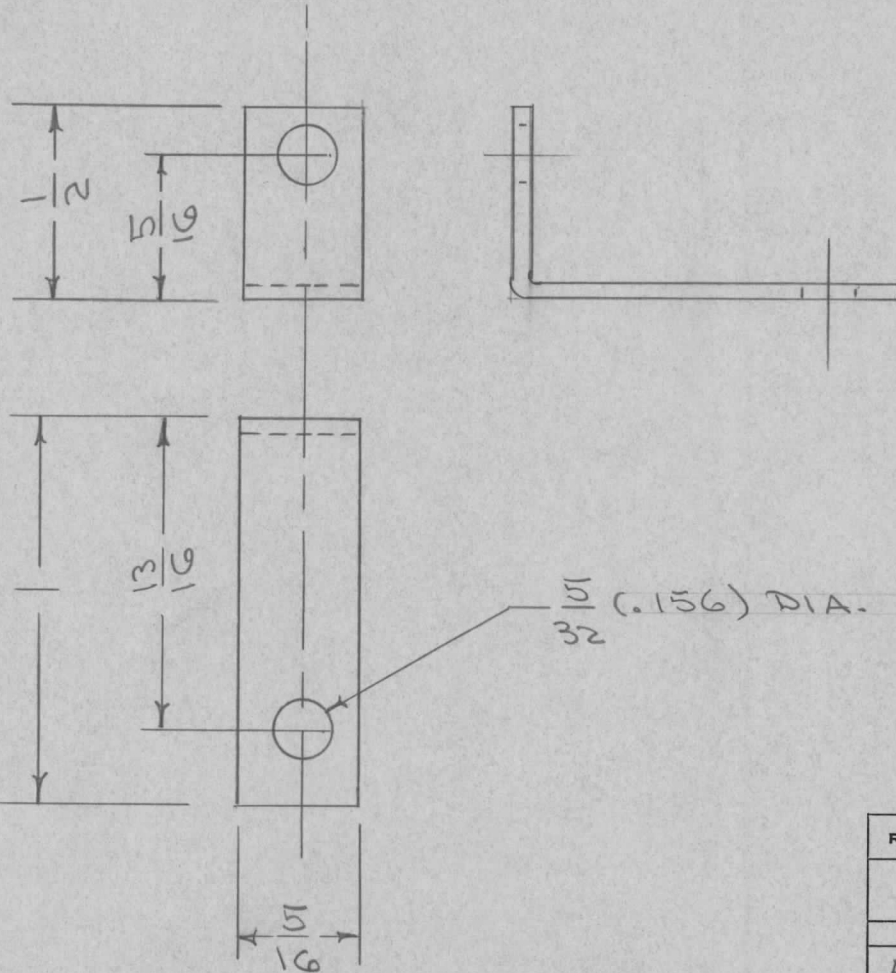

BLANK SIZE - 1 13/32 X 5/16

REQ.	ITEM	PART NO.	DESCRIPTION	SYMBOL
	.051		THE TECHNICAL MATERIEL CORP. MAMARONECK, NEW YORK	
	ALUMINUM			BRACKET, COIL MTG.
	5052 H32		FX-150	
			ADD 8/15/56	R.S.
			DRWN	MECH. DES. APP.
			HEAT TREAT. SPEC.	FINAL APPROVAL
		S-404 IRIDITE	CHECKED	MS-959 A

A	1	5404 IRIDITE WAS S101 CAUSTIC DIP	12-8 59	1001	CP	EMN.	
ISSUE	ITEM	CHANGED FROM	DATE	CN. NO.	DRAFTS	CHECKER	ENG. APP.
TOLERANCES			SCALE				
ALL OTHERS	DEC. DIM. ± FRAC. DIM. ± 1/64 ANGULAR DIM. ±		DRILL, PUNCH, COMMERCIAL STOCK SIZES AND MANUFACTURERS TOLERANCES ARE NOT INCLUDED.				