

REQ. PER UNIT	USED ON			MS-931	A
	MODEL	ASS'Y. NO.	DATE		
1	RTF		4/30/56		
1	RTF-2	MULT	11-20-58		

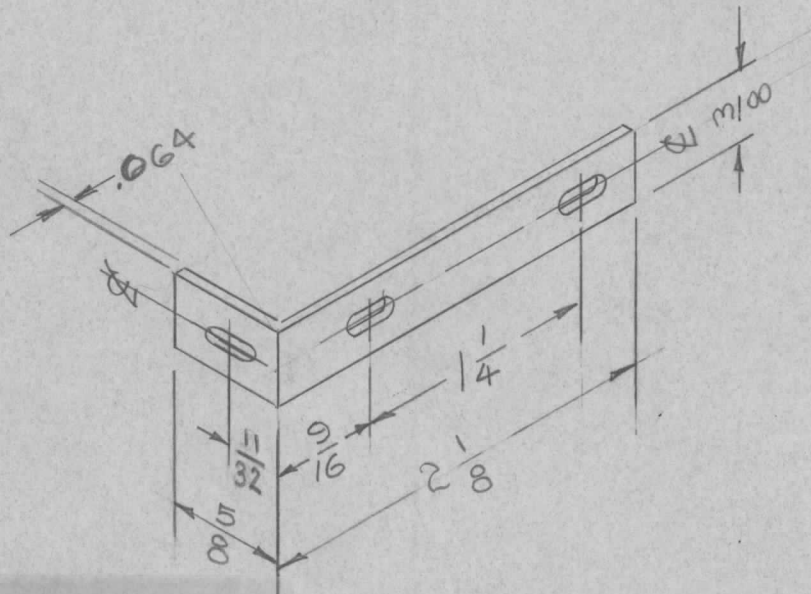

9/64 x 9/32 SLOTS - 3 REQ.

UNLESS OTHERWISE SPECIFIED DIMENSIONS ARE IN INCHES AND INCLUDE CHEMICALLY APPLIED OR PLATED FINISHES		
DECIMALS	TOLERANCES	FRACTIONS
.X ± .05		± 1/64
.XX ± .01		ANGLES
.XXX ± .005		± 0° 30'

CUT HERE
GUARANTEED
2-66

REQ.	ITEM	PART NO.	DESCRIPTION				SYMBOL	
		.064	THE TECHNICAL MATERIEL CORP. MAMARONECK, NEW YORK					
		STOCK SIZE	SUPPORT, L-209					
A	1	ALUMINUM	MULT. GPT-750					
		MATERIAL						
ISSUE	ITEM	CHANGED FROM	DATE	CH. NO.	DRAFTS	CHECKER	ENG. APP.	
		S404 - IRIDITE WAS S101 - CAUSTIC DIP	12-8 59	1001	P		EMN	
TOLERANCES			SCALE:					
DEC. DIM. ±			MAXIMUM ALLOWABLE TOLERANCES HAVE BEEN DETERMINED AND ANY DEVIATIONS WILL BE CAUSE FOR REJECTION.					
FRAC. DIM. ±			REMOVE ALL BURRS AND SHARP EDGES					
ANGULAR DIM. ±								
		5052-H32	TYPE & TEMPER		HEAT TREAT. SPEC.	DRAWN	CHECKED	FINAL APPROVAL
		S404-IRIDITE						
		FINISH & SPEC. NO.	ELEC. DES. APP.	MECH. DES. APP.		MS-931		A