

REVISIONS						
ZONE	LTR	DESCRIPTION	DATE	E.M.N.NO	DRAFT	CHKD APPD
X		Dwg. No. 40M12D7033	3-20-68		C. G. ROSS	
		ORIGINAL RELEASE FOR PRODUCTION	8-15-69		HJT	

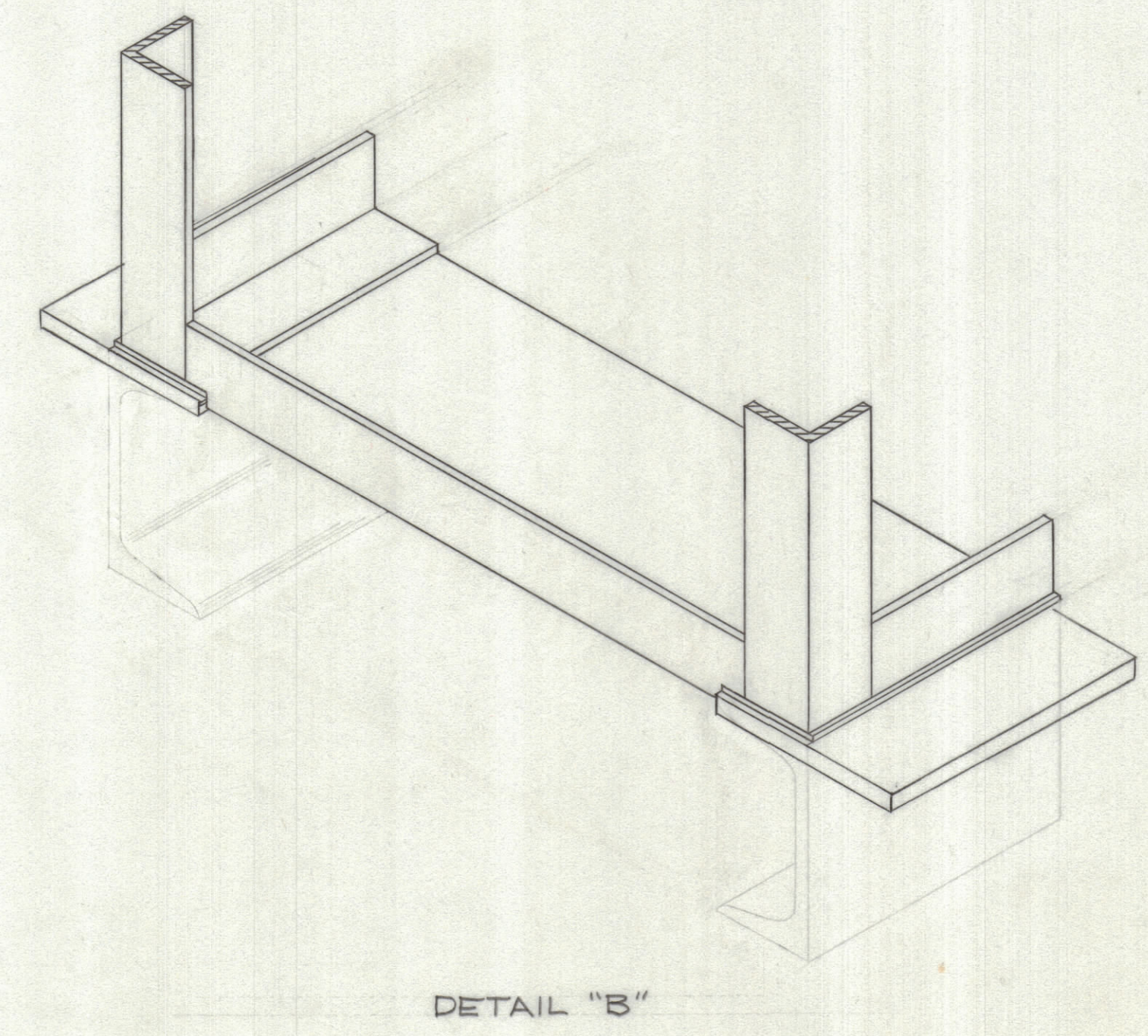
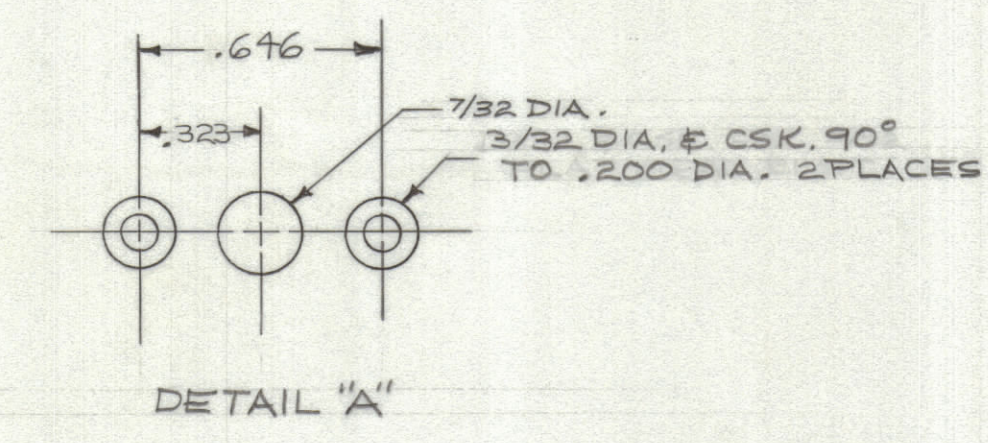
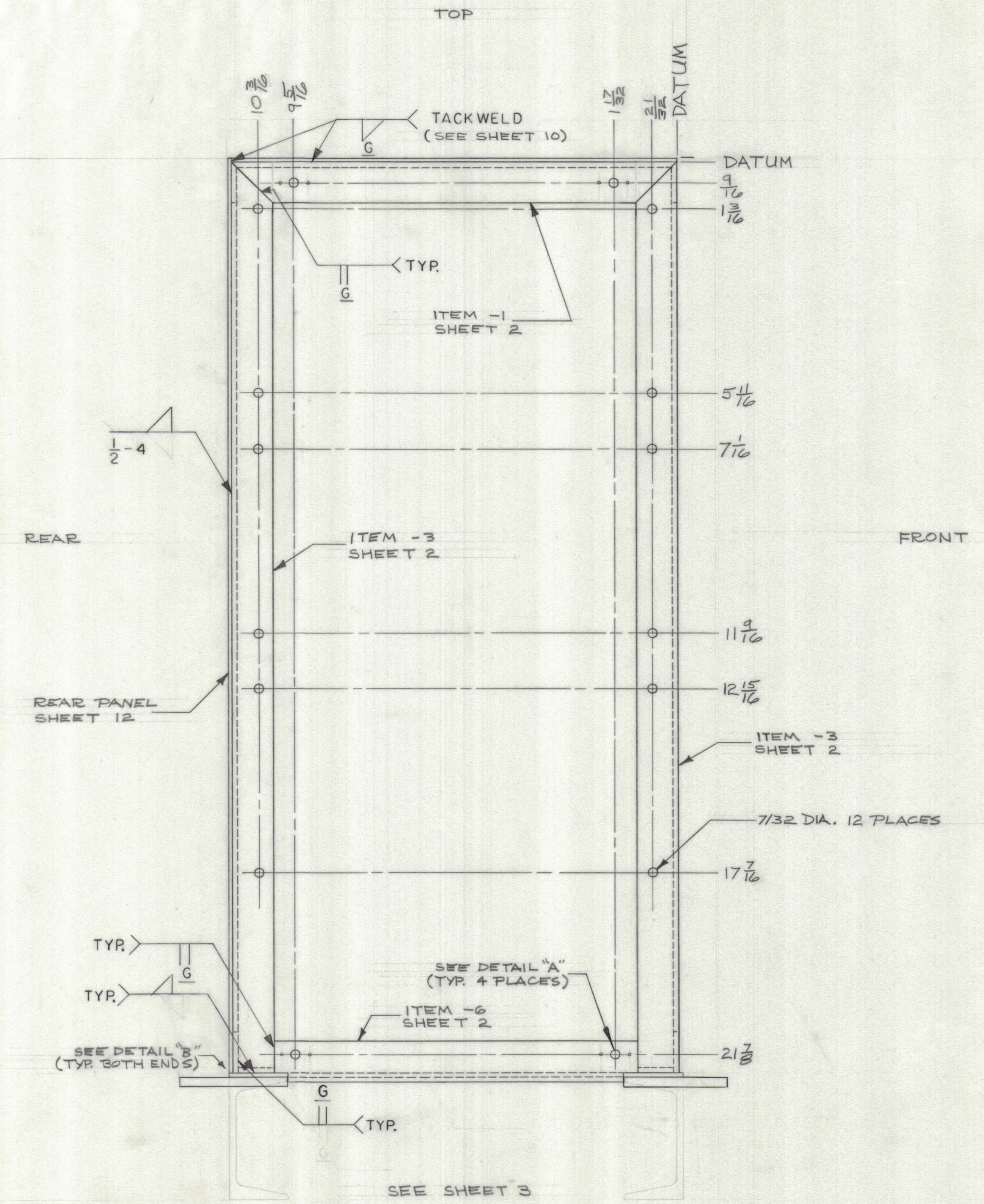

QTY. REQ.	ITEM	PART NO.	DESCRIPTION	SYMBOL
LIST OF MATERIAL				
THE TECHNICAL MATERIEL CORP. MAMARONECK, NEW YORK				
FRAME, LEFT END VIEW BIAS MODULATOR SUPPLY				
SIZE	CODE	IDENT. NO.	DWG. NO.	ISSUE
D		82679	MS 8342	1
SCALE 1/2				SHEET 7 OF

1	SPT-3KVHF	AP-139
QTY / UNIT	MODEL USED ON	ASS'Y NO.
APPLICATION		
CODE		
<small>NOTICE TO PERSONS RECEIVING THIS DRAWING</small> <small>THE TECHNICAL MATERIEL CORPORATION claims proprietary right in the material disclosed herein. This drawing is issued in confidence for engineering information only and may not be reproduced or used to manufacture anything shown hereon without permission from THE TECHNICAL MATERIEL CORPORATION to the user. This drawing is loaned for mutual assistance and is subject to recall at any time.</small>		

UNLESS OTHERWISE SPECIFIED DIMENSIONS ARE IN INCHES AND INCLUDE CHEMICALLY APPLIED OR PLATED FINISHES		FINAL APPROVAL JEP JEP JPM	DATE 3-20-68
TOLERANCES ON		MECH. DES. JEP	DATE 11-5-67
DECIMALS .X ± .05 .XX ± .01 .XXX ± .005		ELECT. DES. [Signature]	DATE 8-17-69
FRACTIONS ± 1/64 ANGLES ± 0° .30'		CHECKED R. Blumeth	DATE 3-20-68
MATERIAL SEE SHEETS 1, 2, 3, 10, & 12		DRAWN ROG	DATE 3-8-68
FINISH SEE SHEET 1			