

4

3

2

1

REVISIONS						
ZONE	LTR	DESCRIPTION	DATE	E.M.N.NO	DRAFT	CHKD APPD

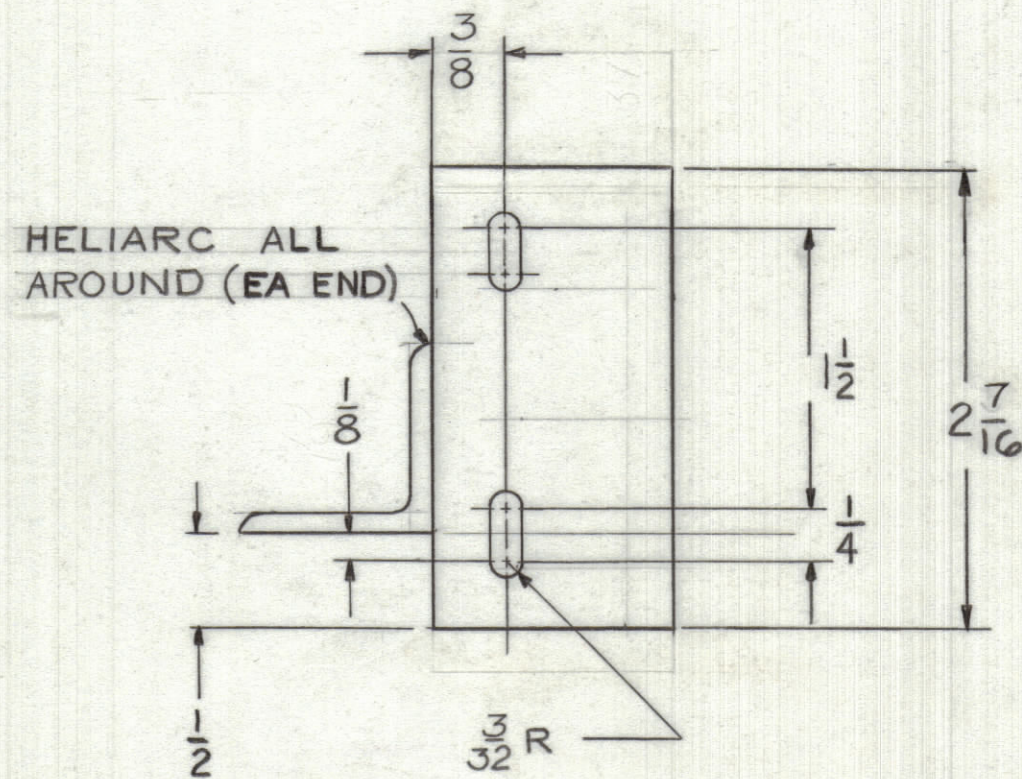
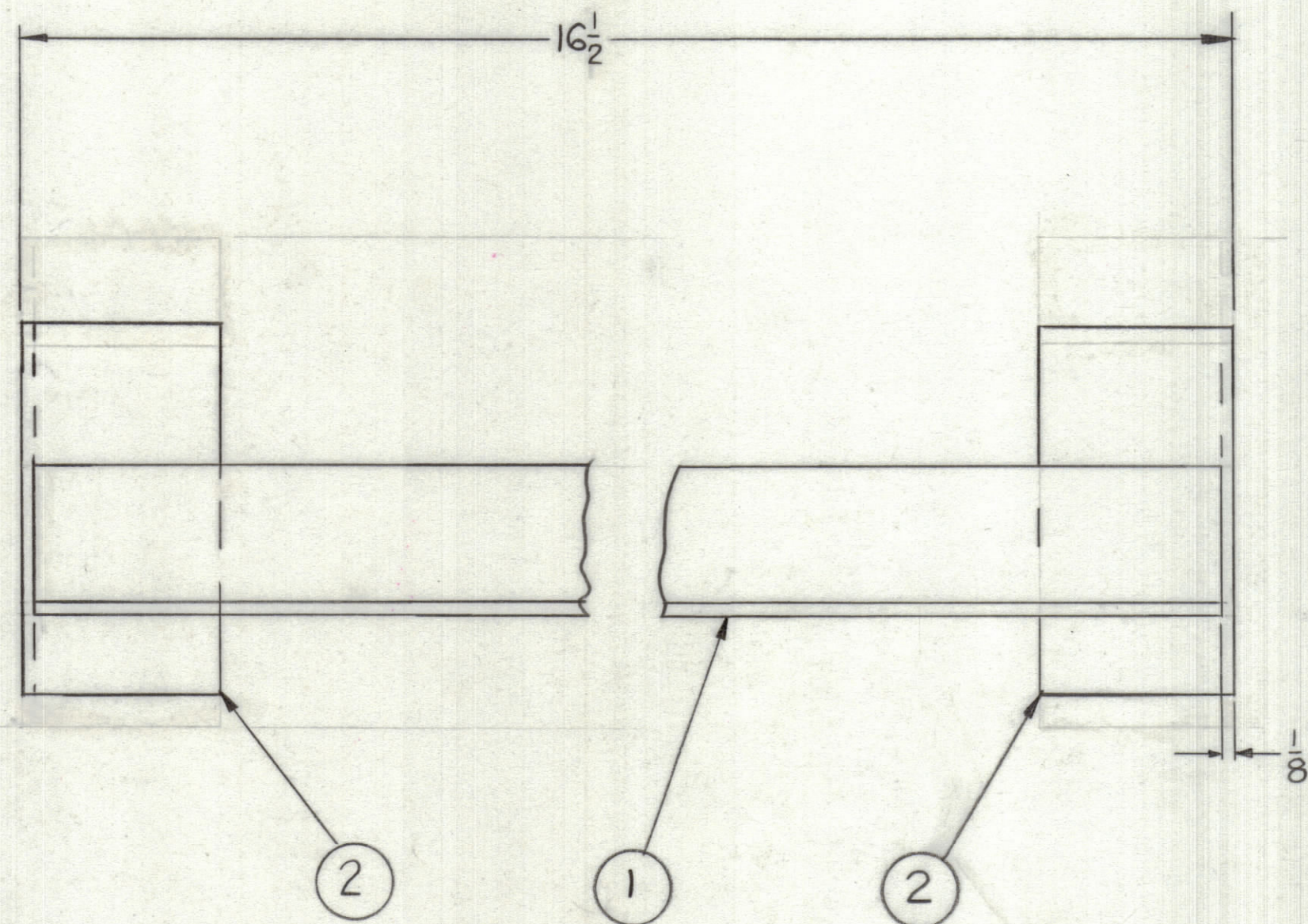

NOTES
 1. THIS DRAWING IS THE PROPERTY OF THE TECHNICAL MATERIEL CORPORATION
 2. IT IS TO BE KEPT IN CONFIDENCE AND NOT REPRODUCED OR USED
 TO MANUFACTURE ANYTHING SHOWN HEREON WITHOUT PERMISSION FROM THE TECHNICAL MATERIEL CORPORATION
 TO THE USER. THIS DRAWING IS LOANED FOR MUTUAL ASSISTANCE AND IS SUBJECT TO RECALL AT ANY TIME.

QTY. REQ.	ITEM	PART NO.	DESCRIPTION	SYMBOL
2	2		ALUM $\angle \frac{1}{8} \times \frac{1}{4} \times \frac{1}{4} \times 2 \frac{7}{16}$	
1	1		ALUM $\angle \frac{1}{8} \times \frac{1}{4} \times \frac{1}{4} \times 16 \frac{1}{4}$	

LIST OF MATERIAL

THE TECHNICAL MATERIEL CORP.
 MAMARONECK, NEW YORK

COMPONENT SUP'T. BRACKET UNITS

UNLESS OTHERWISE SPECIFIED DIMENSIONS ARE IN INCHES AND INCLUDE CHEMICALLY APPLIED OR PLATED FINISHES	FINAL APPROVAL <i>[Signature]</i>	DATE 3-15-68
TOLERANCES ON DECIMALS .X ± .05 .XX ± .01 .XXX ± .005 FRACTIONS ± 1/64 ANGLES ± 0° -30'	MECH. DES. <i>[Signature]</i>	DATE 3-16-68
	ELECT. DES. <i>[Signature]</i>	DATE 3-16-68
	CHECKED <i>[Signature]</i>	DATE 3-20-68
	DRAWN <i>[Signature]</i>	DATE 3-3-68

QTY / UNIT	MODEL USED ON	ASS'Y NO.
APPLICATION		
CODE		
NOTICE TO PERSONS RECEIVING THIS DRAWING THE TECHNICAL MATERIEL CORPORATION claims proprietary right in the material disclosed hereon. This drawing is issued in confidence for engineering information only and may not be reproduced or used to manufacture anything shown hereon without permission from THE TECHNICAL MATERIEL CORPORATION to the user. This drawing is loaned for mutual assistance and is subject to recall at any time.		
MATERIAL NOTED		
FINISH S404-IRIDITE		

SIZE	CODE IDENT.NO.	DWG NO.	ISSUE
C	82679	MS8204	Ø
SCALE: FULL			SHEET 1 OF 1

4

3

2

1

MS8204