

APPLICATION

REVISIONS

QTY	MODEL USED ON	ASS'Y NO.	LTR	DESCRIPTION	DATE	E.M.N.NO	DRAFT	CHKD	APPD

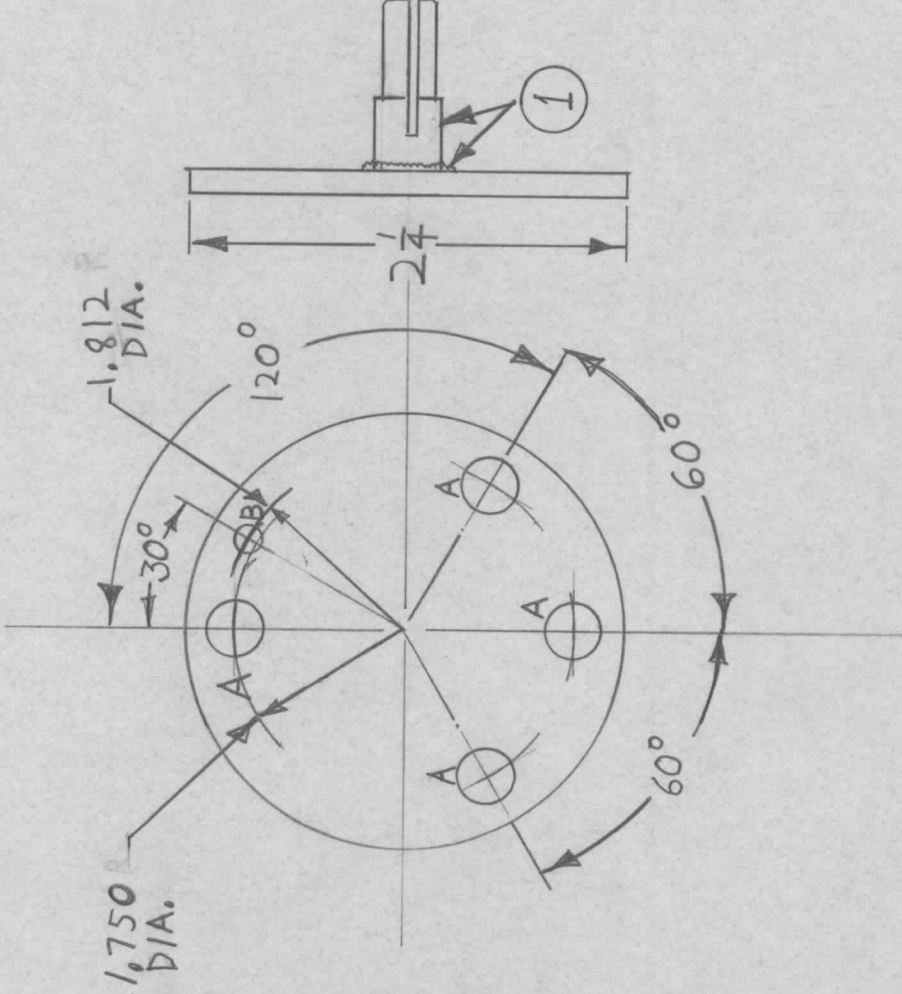

NOTE:
 ① INNER CONNECTOR 1/2 OF
 ANDREWS P/N 34389
 SILVER SOLDER
 AND HEAT TREAT

HOLE CHART		
LFT.	DESCRIPTION	QUAN.
A	9/32 DIA.	4
B	.129 DIA.	1

REQ'D ITEM	PART NUMBER	DESCRIPTION	SYM.
LIST OF MATERIAL			
FINAL APPROVAL <i>SM</i>	DATE 9/11/67	THE TECHNICAL MATERIEL CORP. MAMARONECK, NEW YORK GROUNDING PLATE NO. 384 FIELD ANT.	ISSUE Ø
MECH. DES. L. NOTARANGELO	DATE 8/29/67		
ELECT. DES.	DATE		
CHECKED G. URLANDI	DATE 12-13-67	SIZE A	DWG NO. 40MS8106
DRAWN L. NOTARANGELO	DATE 8/29/67	SCALE	SHEET OF
UNLESS OTHERWISE SPECIFIED DIMENSIONS ARE IN INCHES AND INCLUDE CHEMICALLY APPLIED OR PLATED FINISHES DECIMALS FRACTIONS .X ± .05 TOLS. 1/64 .XX ± .01 ANGLES 0°-30' .XXX ± .005			
MATERIAL .125 HARD COP.			
FINISH			
NOTICE TO PERSONS RECEIVING THIS DRAWING THE TECHNICAL MATERIEL CORPORATION claims proprietary right in the material disclosed hereon. This drawing is issued in confidence for engineering information only and may not be reproduced or used to manufacture anything shown hereon without permission from THE TECHNICAL MATERIEL CORPORATION to the user. This drawing is loaned for mutual assistance and is subject to recall at any time.			