

## APPLICATION

QTY 1

MODEL USED ON  $\Delta$ MC-32

ASSY NO.

LTR  $\emptyset$ 

DESCRIPTION ORIGINAL RELEASE

DATE 1-2-90

E.M.N.NO

DRAFT GDL

CHKD

APPD

## REVISIONS

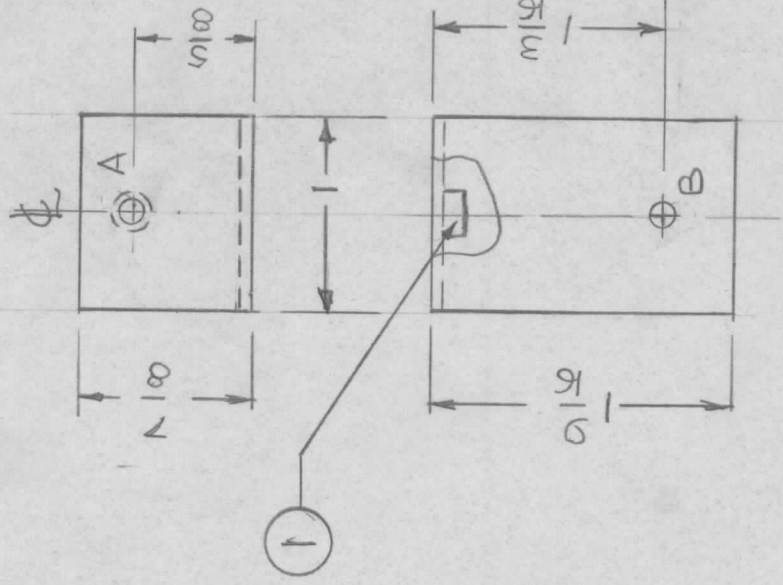

HOLE -

A - .161<sup>N</sup> - .164 DIA

B - 9/64 DIA

REQ'D	ITEM	PART NUMBER	DESCRIPTION	SYM.
1	1	NT129-0440	NUT ROUND	A

## LIST OF MATERIAL

FINAL APPROVAL	DATE
MECH. DES.	DATE
ELECT. DES.	DATE
CHECKED	DATE
DRAWN G.D.L	DATE 1-2-89

THE TECHNICAL MATERIEL CORP.  
MAMARONECK, NEW YORK

BRACKET SUPPORT CHASSIS

NOTICE TO PERSONS RECEIVING THIS DRAWING  
THE TECHNICAL MATERIEL CORPORATION claims proprietary right in the material disclosed hereon. This drawing is issued in confidence for engineering information only and may not be reproduced or used to manufacture anything shown hereon without permission from THE TECHNICAL MATERIEL CORPORATION to the user. This drawing is loaned for mutual assistance and is subject to recall at any time.

SIZE A

CODE IDENT. NO. 82679

DWG NO. MS 7200

ISSUE  $\emptyset$ 

SCALE 1:1

SHEET

OF

APPLICATION

QTY MODEL USED ON ASS'Y NO. LTR

AW 101-4

REVISIONS

DESCRIPTION	DATE	E.M.N.NO	DRAFT	CHKD	APPD
ORIGINAL RELEASE FOR PROD.	1-3-99				
A. NOTE ADDED	3-12-91		G.D.L.		

NOTE  
OBSOLETE  
Replace By  
MS 7255

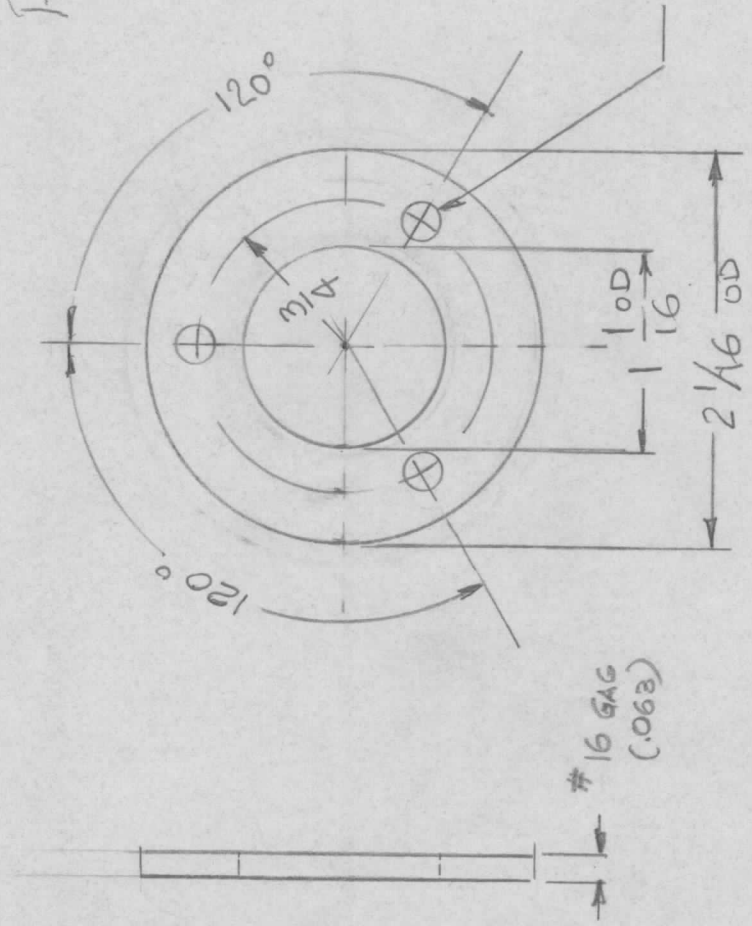

# 16 GAG  
(.063)

13/64 DIA PUNCHED  
HOLES 120° APART (3REQ)

UNLESS OTHERWISE SPECIFIED DIMENSIONS ARE IN INCHES AND INCLUDE CHEMICALLY APPLIED OR PLATED FINISHES	REQ'D ITEM	PART NUMBER	DESCRIPTION	SYM.
DECIMALS .X ± .05 .XX ± .01 .XXX ± .005 FRACTIONS 1/64 ANGLES 0° - 30'	FINAL APPROVAL		<b>LIST OF MATERIAL</b>  <b>THE TECHNICAL MATERIEL CORP.</b> MAMARONECK, NEW YORK  GUY RING ANTENNA	
	MECH. DES.			
	ELECT. DES.			
	CHECKED			
	DRAWN	G.D.L.		
MATERIAL 16 GAG Cold ROLLED SS FINISH PASSIVATE				

SIZE	CODE IDENT. NO.	DWG NO.	ISSUE
A	82679	MS 7203	A
SCALE	1:1	SHEET	OF

NOTICE TO PERSONS RECEIVING THIS DRAWING  
 THE TECHNICAL MATERIEL CORPORATION claims proprietary right in the material disclosed hereon. This drawing is issued in confidence for engineering information only and may not be reproduced or used to manufacture anything shown hereon without permission from THE TECHNICAL MATERIEL CORPORATION to the user. This drawing is loaned for mutual assistance and is subject to recall at any time.

APPLICATION

REVISIONS

QTY	MODEL USED ON	ASSY NO.	LTR	DESCRIPTION	DATE	E.M.N.NO	DRAFT	CHKD	APPD
16	TER-4K/600		Ø	ORIGINAL RELEASE FOR P100.					

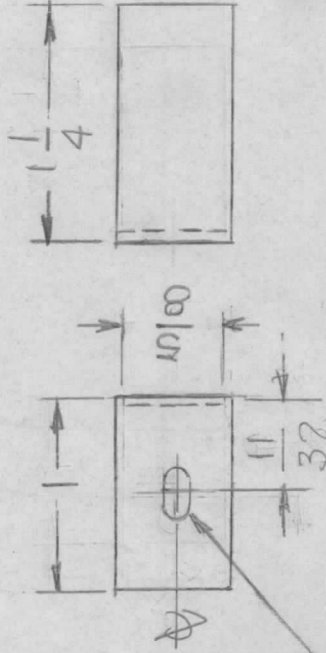

11/64 X 1/4  
SLOT

UNLESS OTHERWISE SPECIFIED DIMENSIONS ARE IN INCHES AND INCLUDE CHEMICALLY APPLIED OR PLATED FINISHES		REQ'D	ITEM	PART NUMBER	DESCRIPTION	SYM.	
DECIMALS	FRACTIONS	LIST OF MATERIAL					
.X ± .05 TOLS.	1/64						
.XX ± .01 ANGLES	0° .30'	FINAL APPROVAL	DATE	THE TECHNICAL MATERIEL CORP.			
.XXX ± .005		MECH. DES.	DATE	MAMARONECK, NEW YORK			
MATERIAL .040 THICK		ELECT. DES.	DATE	RESISTOR HOLDER			
COPPER		CHECKED	DATE	SIZE	CODE IDENT. NO.	DWG NO.	
FINISH		DRAWN G.D.L	DATE 5-11-83	A	82679	MS 7210	
NOTICE TO PERSONS RECEIVING THIS DRAWING				SCALE	1:1	SHEET	OF
THE TECHNICAL MATERIEL CORPORATION claims proprietary right in the material disclosed hereon. This drawing is issued in confidence for engineering information only and may not be reproduced or used to manufacture anything shown hereon without permission from THE TECHNICAL MATERIEL CORPORATION to the user. This drawing is loaned for mutual assistance and is subject to recall at any time.							ISSUE
							Ø

REVISIONS

APPLICATION

QTY	MODEL USED ON	ASS'Y NO.	LTR	DESCRIPTION	DATE	E.M.N.NO	DRAFT	CHKD	APPD
4	BSP-7S		Ø	ORIGINAL RELEASE FOR PROD.	1-16-90		G.D.L		
4	BSP-7								

MARK TMC PART NUMBER  
1/8 HIGH GOTHIC WITH LATEST  
REVISION LETTER

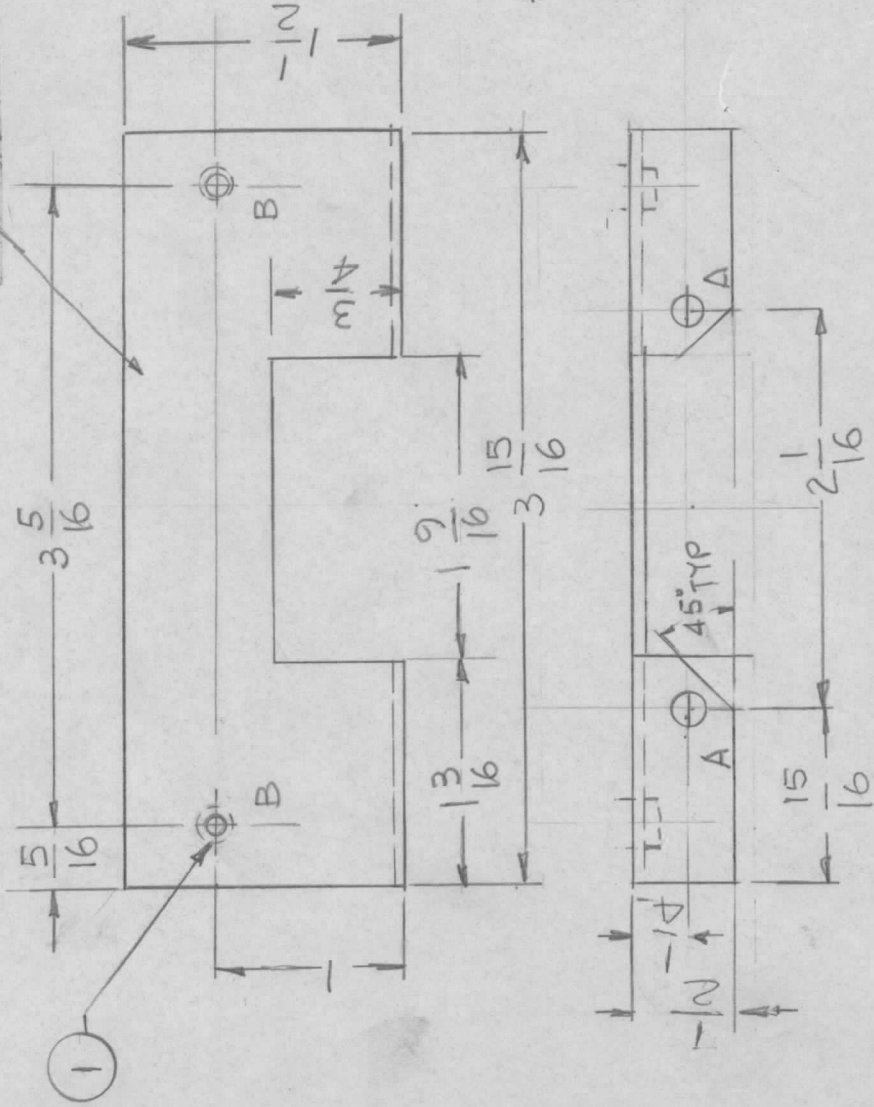

HOLES  
A - 1/16 DIA. 2 REQ.  
B - .161-.164 DIA

2	1	NT 129-040-4	NUT ROUND		
REQ'D	ITEM	PART NUMBER	DESCRIPTION	SYM.	

LIST OF MATERIAL					
THE TECHNICAL MATERIEL CORP. MAMARONECK, NEW YORK					
FINAL APPROVAL	DATE				
<i>gbs</i>	1/15/90				
MECH. DES.	DATE				
ELECT. DES.	DATE				
CHECKED	DATE				
DRAWN	DATE				
G.D.L	9-14-89				
BRACKET, MTG PC.B.D.		SIZE	CODE IDENT. NO.	DWG NO.	ISSUE
		A	82679	MS 7218	Ø
YEL. IRIDITE		SCALE	1:1	SHEET	OF

NOTICE TO PERSONS RECEIVING THIS DRAWING  
THE TECHNICAL MATERIEL CORPORATION claims proprietary right in the material disclosed hereon. This drawing is issued in confidence for engineering information only and may not be reproduced or used to manufacture anything shown hereon without permission from THE TECHNICAL MATERIEL CORPORATION to the user. This drawing is loaned for mutual assistance and is subject to recall at any time.

REVISIONS

APPLICATION

QTY	MODEL USED ON	ASS'Y NO.	LTR	DESCRIPTION	DATE	E.M.N.NO	DRAFT	CHKD	APPD
4	BSP-7		Ø	ORIGINAL RELEASE FOR PROD	1-3/80		G.D.L		
4	BSP-7S								

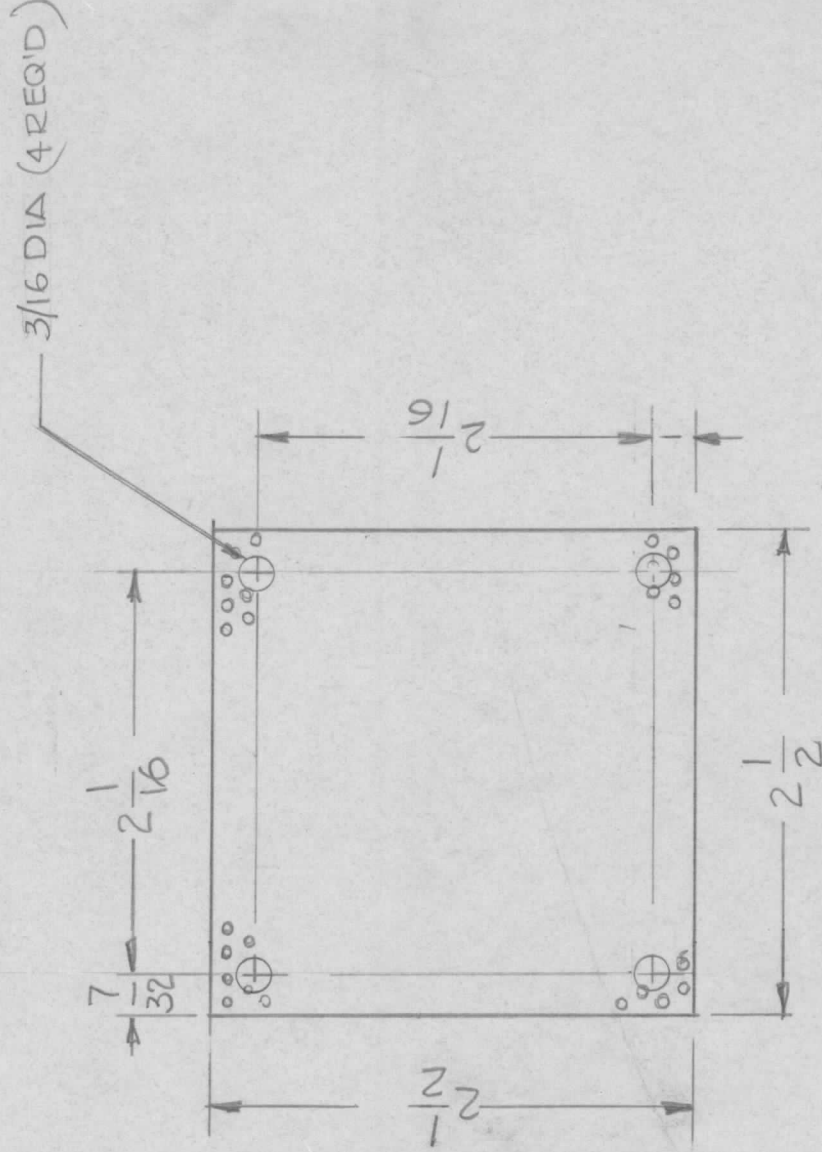

MATERIAL: 3003H14 GAGE 16 ALUM. ANODIZED  
 .050 HOLE DIA. 7/64" C.T.O.C. SPACING

REF: MCMASTER - CARR (CATAL. 95 PAG 2144)

UNLESS OTHERWISE SPECIFIED DIMENSIONS ARE IN INCHES AND INCLUDE CHEMICALLY APPLIED OR PLATED FINISHES	REQ'D ITEM	PART NUMBER	DESCRIPTION	SYM.
DECIMALS .X ± .05 .XX ± .01 .XXX ± .005	FINAL APPROVAL		LIST OF MATERIAL	
FRACTIONS 1/64	MECH. DES.		THE TECHNICAL MATERIEL CORP.	
TOLS. 0°-30'	ELECT. DES.		MAMARONECK, NEW YORK	
MATERIAL SEE NOTE	CHECKED		GRILL, SPEAKER	
FINISH SEE NOTE	DRAWN	G.D.L.		

NOTICE TO PERSONS RECEIVING THIS DRAWING		SIZE	CODE IDENT. NO.	DWG NO.	ISSUE
THE TECHNICAL MATERIEL CORPORATION claims proprietary right in the material disclosed hereon. This drawing is issued in confidence for engineering information only and may not be reproduced or used to manufacture anything shown hereon without permission from THE TECHNICAL MATERIEL CORPORATION to the user. This drawing is loaned for mutual assistance and is subject to recall at any time.		A	82679	MS 7219	Ø
SCALE 1:1		SHEET		OF	

APPLICATION

REVISIONS

QTY	MODEL USED ON	ASS'Y NO.	LTR	DESCRIPTION	DATE	E.M.N.NO	DRAFT	CHKD	APPD
			Ø	ØRIG. RELEASE FOR PROD.	3-20-91		GDL		

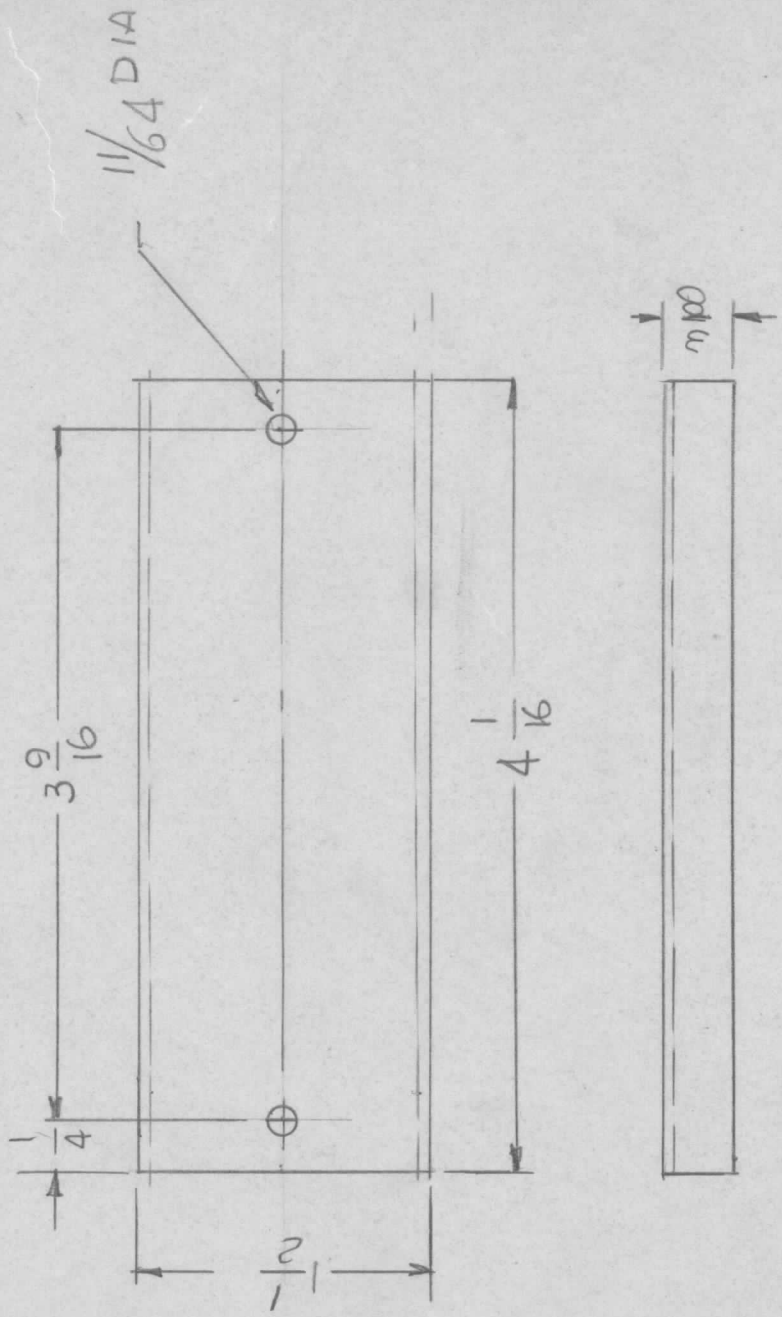

37624  
500  
4062

UNLESS OTHERWISE SPECIFIED DIMENSIONS ARE IN INCHES AND INCLUDE CHEMICALLY APPLIED OR PLATED FINISHES		REQ'D	ITEM	PART NUMBER	DESCRIPTION	SYM.
DECIMALS	FRACTIONS	LIST OF MATERIAL				
.X ± .05	1/64	FINAL APPROVAL	DATE	THE TECHNICAL MATERIEL CORP.		
.XX ± .01	TOLS.	Mech. DES.	DATE	MAMARONECK, NEW YORK		
.XXX ± .005	ANGLES	ELECT. DES.	DATE	BRACKET, XFMR		
	0°-30°	CHECKED	DATE			
MATERIAL 0.62 THK		DRAWN	DATE			
ALUM. 5052-H32		GDL	1-27-89			
FINISH 5404						
YEL IRIDITE						

NOTICE TO PERSONS RECEIVING THIS DRAWING		SIZE	CODE IDENT. NO.	DWG NO.	ISSUE
THE TECHNICAL MATERIEL CORPORATION claims proprietary right in the material disclosed hereon. This drawing is issued in confidence for engineering information only and may not be reproduced or used to manufacture anything shown hereon without permission from THE TECHNICAL MATERIEL CORPORATION to the user. This drawing is loaned for mutual assistance and is subject to recall at any time.		A	82679	MS 7224	Ø
SCALE 1:1	SHEET	OF			

APPLICATION

REVISIONS

QTY	MODEL USED ON	ASSY NO.	LTR	DESCRIPTION	DATE	E.M.N.NO	DRAFT	CHKD	APPD
2	TER 500/1K	ID 478	Ø	ORIGINAL RELEASE FOR PROD.	5-31-94		G.P.L.		GR
2	TER -								

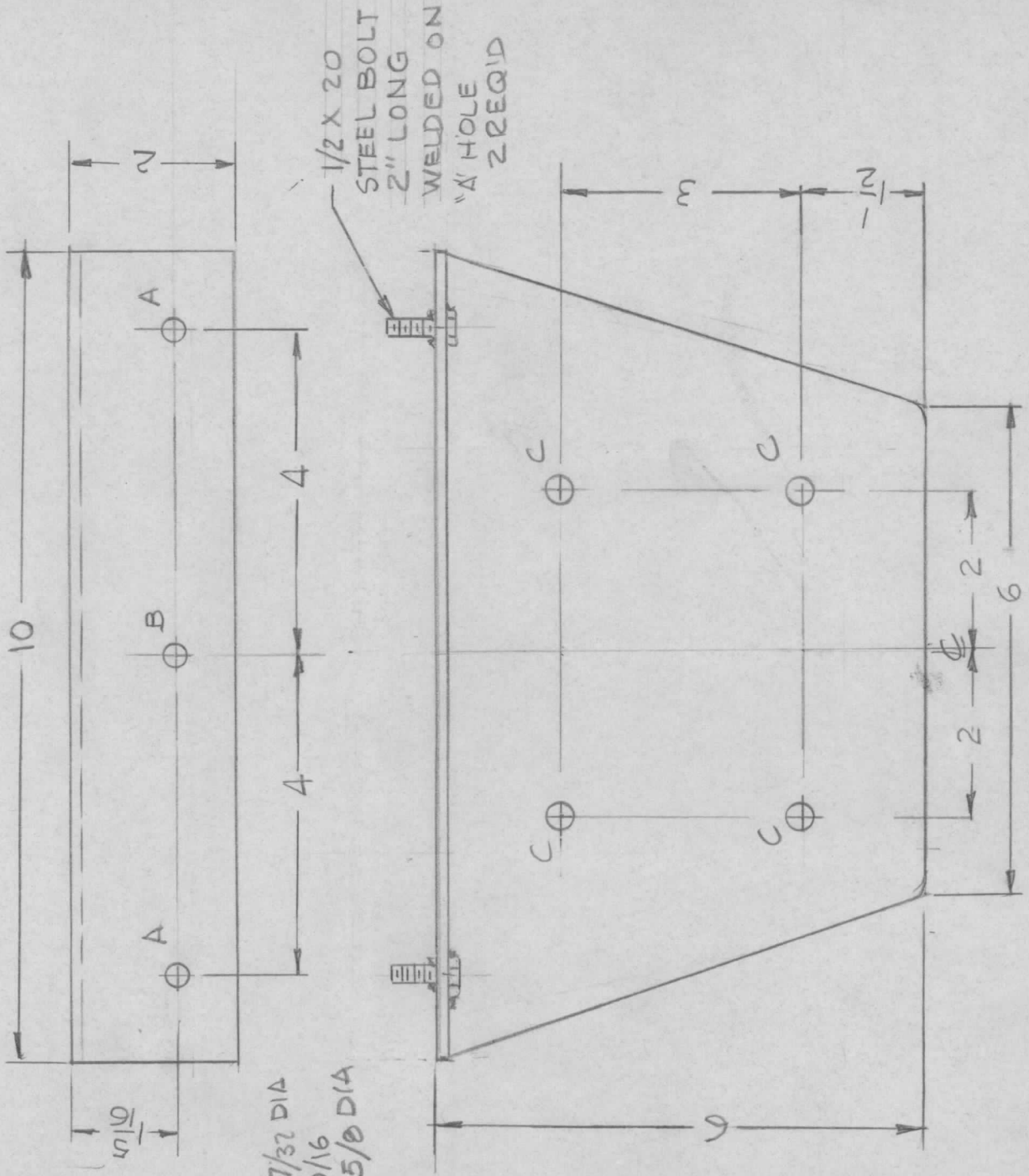

A- 17/32 DIA  
 B- 9/16  
 C- 5/8 DIA

UNLESS OTHERWISE SPECIFIED DIMENSIONS ARE IN INCHES AND INCLUDE CHEMICALLY APPLIED OR PLATED FINISHES	REQ'D ITEM	PART NUMBER	DESCRIPTION	SYM.
DECIMALS .X ± .05 .XX ± .01 .XXX ± .005	FINAL APPROVAL		LIST OF MATERIAL  <b>THE TECHNICAL MATERIEL CORP.</b> MAMARONECK, NEW YORK  BRACKET, POLE MTG.	
FRACTIONS 1/64	MECH. DES.			
TOLS. 0°-30'	ELECT. DES.			
MATERIAL 1/8THK STEEL COLD ROLLED	CHECKED			
FINISH PRIMER PAINT LIGHT GREY TEXTURED	DRAWN			
DATE 5/27/94		DATE 5/27/94		
DATE 3/10/90		DATE 3/10/90		

SIZE <b>A</b>	CODE IDENT. NO. <b>MS 7230</b>	ISSUE
SCALE <b>1/2</b>	SHEET	OF

NOTICE TO PERSONS RECEIVING THIS DRAWING  
 THE TECHNICAL MATERIEL CORPORATION claims proprietary right in the material disclosed hereon. This drawing is issued in confidence for engineering information only and may not be reproduced or used to manufacture anything shown hereon without permission from THE TECHNICAL MATERIEL CORPORATION to the user. This drawing is loaned for mutual assistance and is subject to recall at any time.

REVISIONS

APPLICATION

QTY	MODEL USED ON	ASS'Y NO.	LTR	DESCRIPTION	DATE	E.M.N.NO	DRAFT	CHKD	APPD
1	TER-500/1K	AS867	Ø	ORIG. RELEASE FOR PRODUCTION	3-20-91		G.D.L		

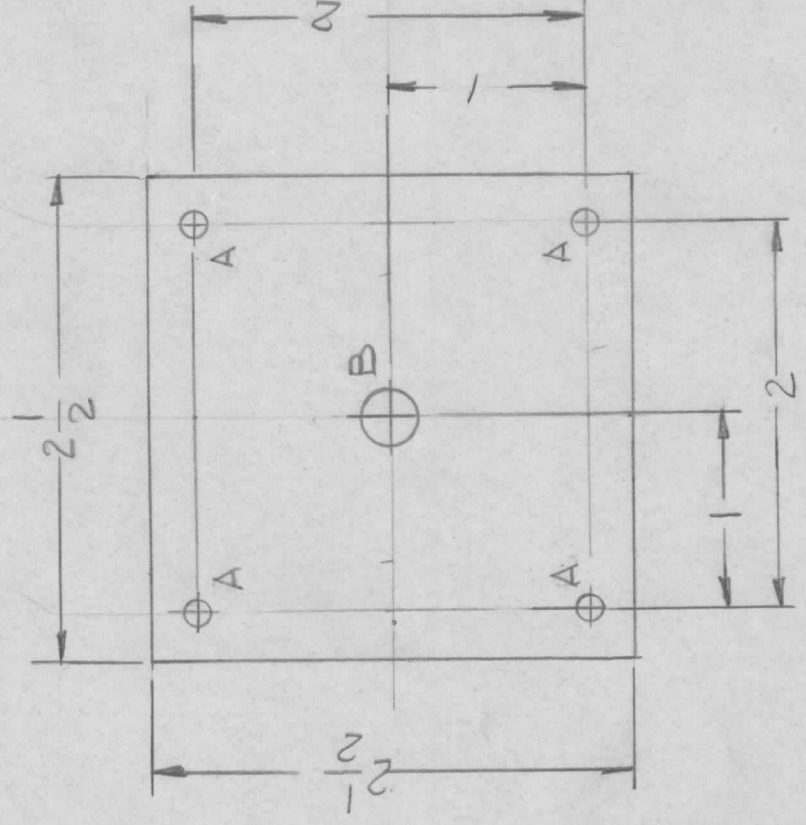

HOLES  
 A - 3/16 DIA 4 REQ'D  
 B - 5/16 DIA

UNLESS OTHERWISE SPECIFIED DIMENSIONS ARE IN INCHES AND INCLUDE CHEMICALLY APPLIED OR PLATED FINISHES	REQ'D	ITEM	PART NUMBER	DESCRIPTION	SYM.
DECIMALS .X ± .05 .XX ± .01 .XXX ± .005				LIST OF MATERIAL	
FRACTIONS 1/64 ANGLES 0°-30°				THE TECHNICAL MATERIEL CORP. MAMARONECK, NEW YORK	
MATERIAL: 063 THK ALY-5052-H32				PLATE MTG. GROUND	
FINISH S404 VEL IRIDITED					
PRIMER PAINT LIGHT GREY TEXTURED					
FINAL APPROVAL <i>EBB</i>					
MECH. DES.					
ELECT. DES.					
CHECKED					
DRAWN G.D.L					
DATE <i>4/1/90</i>					
DATE					
DATE					
DATE					
DATE					
SIZE A	CODE IDENT. NO. 82679	DWG NO. MS 7231			ISSUE Ø
SCALE 1:1			SHEET		OF

NOTICE TO PERSONS RECEIVING THIS DRAWING  
 THE TECHNICAL MATERIEL CORPORATION claims proprietary right in the material disclosed hereon. This drawing is issued in confidence for engineering information only and may not be reproduced or used to manufacture anything shown hereon without permission from THE TECHNICAL MATERIEL CORPORATION to the user. This drawing is loaned for mutual assistance and is subject to recall at any time.



REVISIONS

APPLICATION

QTY	MODEL USED ON	ASSY NO.	LTR	DESCRIPTION	DATE	E.M.N.NO	DRAFT	CHKD	APPD
1	DAC-8		Ø	ORIG. RELEASE FOR PRODUCTION	3-19-91		G.D.L		

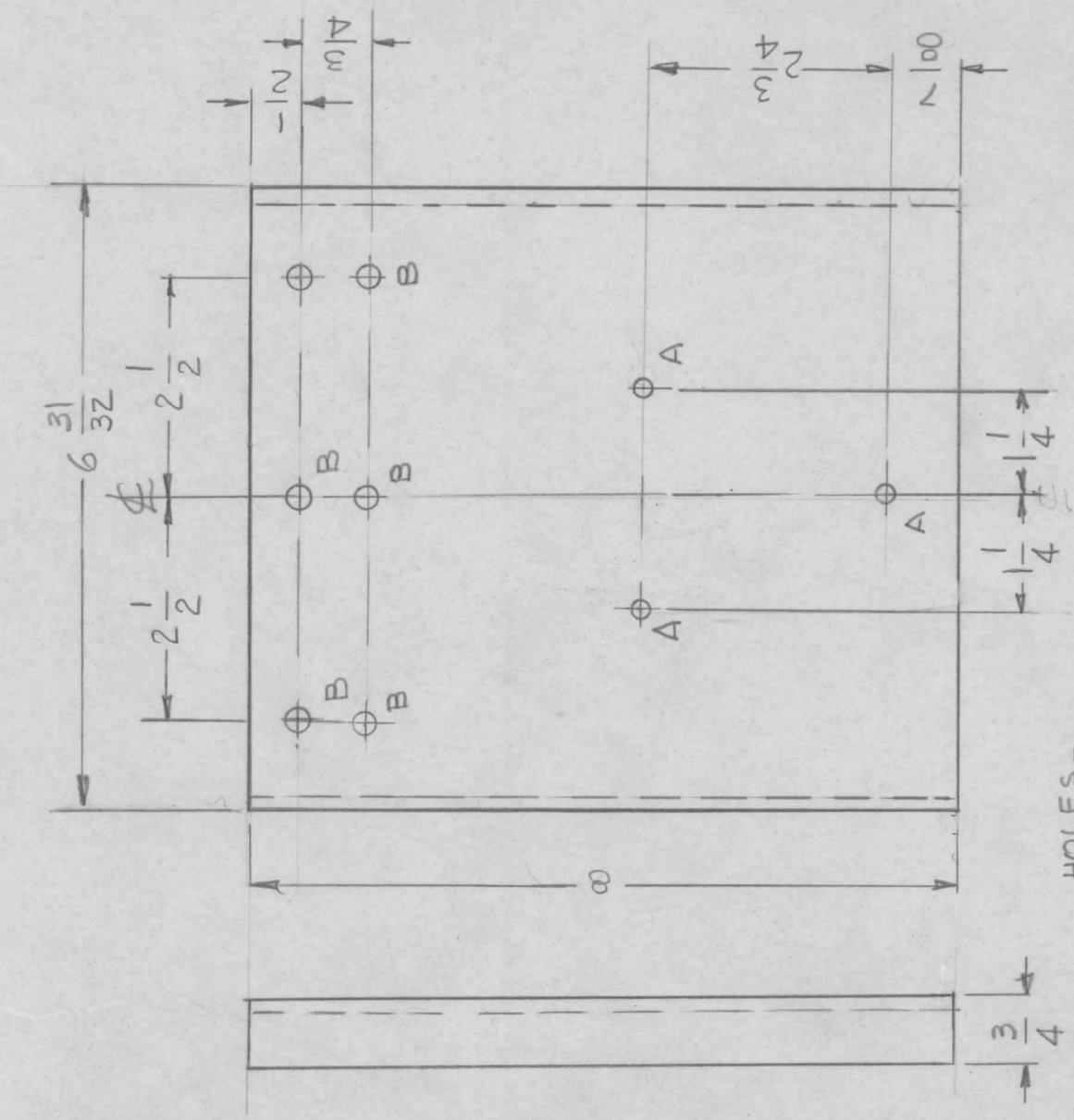

HOLES -  
 A - 9/32 DIA 3REQ'D  
 B - 5/16 DIA 6REQ'D

UNLESS OTHERWISE SPECIFIED DIMENSIONS ARE IN INCHES AND INCLUDE CHEMICALLY APPLIED OR PLATED FINISHES		REQ'D ITEM		PART NUMBER		DESCRIPTION		SYM.	
DECIMALS	FRACTIONS	FINAL APPROVAL	MECH. DES.	DATE	DATE	LIST OF MATERIAL			
.X ± .05	TOLS. 1/64	ØØØ		3/20/91		THE TECHNICAL MATERIEL CORP.			
.XX ± .01	ANGLES 0°-30'					MAMARONECK, NEW YORK			
.XXX ± .005						PLATE MTG. CASE -			
MATERIAL 1/8THK ALUM. 5052-H32						SIZE	CODE IDENT. NO.	DWG NO.	ISSUE
FINISH 5404 - YELLOW IRIDITED						A	82679	MS 7234	Ø
TWO COATS GREY EPOXY						SCALE	SHEET	OF	
						1/2			

NOTICE TO PERSONS RECEIVING THIS DRAWING  
 THE TECHNICAL MATERIEL CORPORATION claims proprietary right in the material disclosed hereon. This drawing is issued in confidence for engineering information only and may not be reproduced or used to manufacture anything shown hereon without permission from THE TECHNICAL MATERIEL CORPORATION to the user. This drawing is loaned for mutual assistance and is subject to recall at any time.

REVISIONS

APPLICATION

QTY	MODEL USED ON	ASS'Y NO.	LTR	DESCRIPTION	DATE	E.M.N.NO	DRAFT	CHKD	APPD
1	AW-101-A		A	REDRAWN & UPDATED	3-21-91		GDL		<i>[Signature]</i>

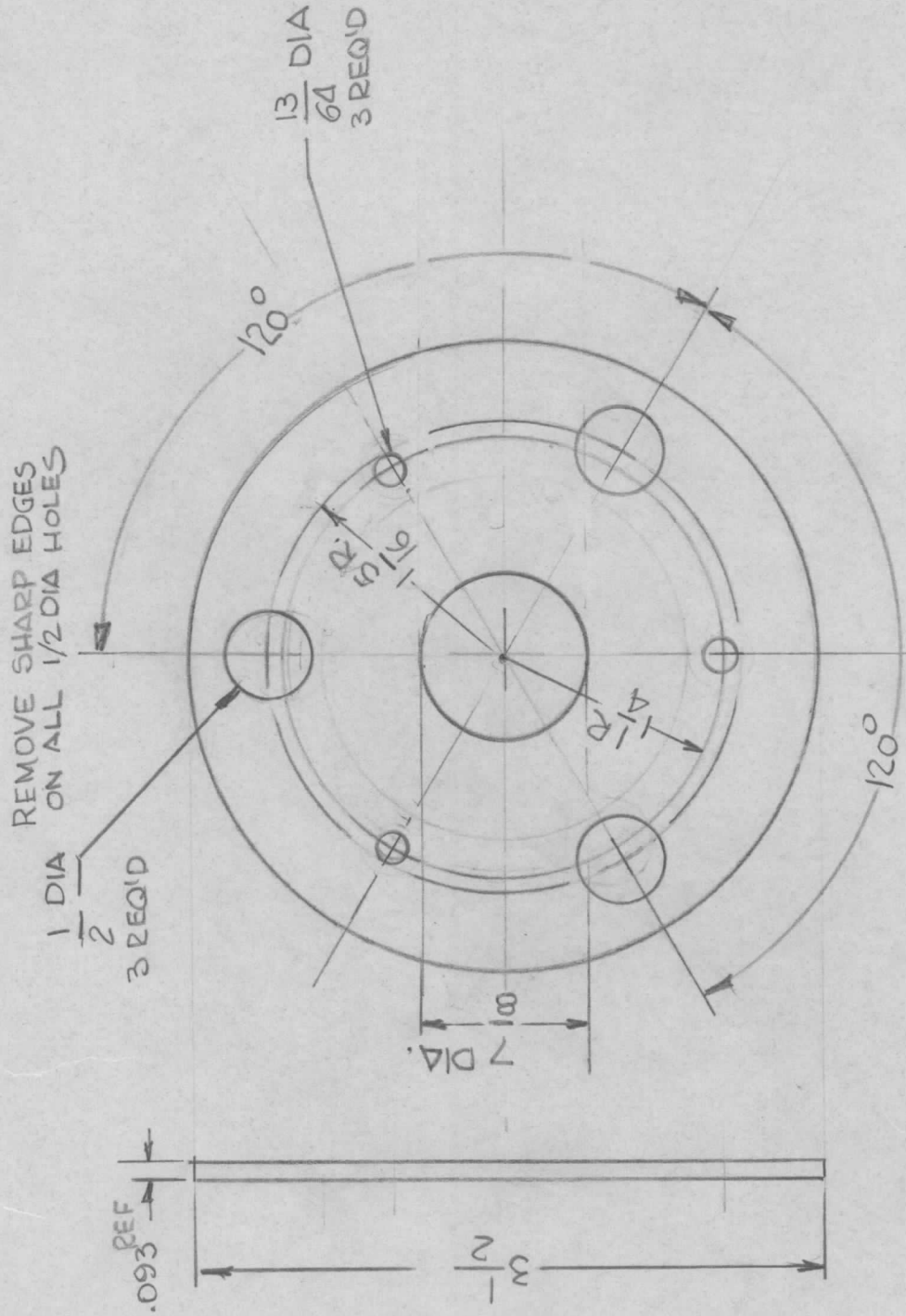

UNLESS OTHERWISE SPECIFIED DIMENSIONS ARE IN INCHES AND INCLUDE CHEMICALLY APPLIED OR PLATED FINISHES		REQ'D	ITEM	PART NUMBER	DESCRIPTION	SYM.
DECIMALS .X ± .05 .XX ± .01 .XXX ± .005		LIST OF MATERIAL				
FRACTIONS 1/64		THE TECHNICAL MATERIEL CORP.				
TOLS. ANGLES 0°-30'		MAMARONECK, NEW YORK				
MATERIAL # 13 GA - STAINLESS STEEL FINISH		GUY RING, ANTENNA				
NOTICE TO PERSONS RECEIVING THIS DRAWING THE TECHNICAL MATERIEL CORPORATION claims proprietary right in the material disclosed hereon. This drawing is issued in confidence for engineering information only and may not be reproduced or used to manufacture anything shown hereon without permission from THE TECHNICAL MATERIEL CORPORATION to the user. This drawing is loaned for mutual assistance and is subject to recall at any time.		SIZE	CODE IDENT. NO.	DWG NO.	ISSUE	
		A	82679	MS7255	A	
		SCALE	1:1	SHEET	OF	

APPLICATION

REVISIONS

QTY	MODEL USED ON	ASS'Y NO.	LTR	DESCRIPTION	DATE	E.M.N.NO	DRAFT	CHKD	APPD
1	AZ 102		Ø	ORIGINAL RELEASE FOR PROD.	1-5-93		G.D.L		

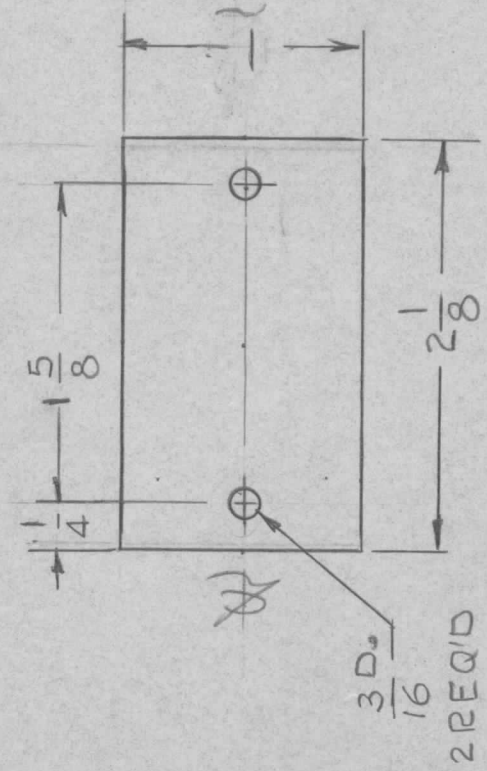

UNLESS OTHERWISE SPECIFIED DIMENSIONS ARE IN INCHES AND INCLUDE CHEMICALLY APPLIED OR PLATED FINISHES	REQ'D	ITEM	PART NUMBER	DESCRIPTION	SYM.
DECIMALS				LIST OF MATERIAL	
FRACTIONS				THE TECHNICAL MATERIEL CORP.	
X ± .05 TOLS. 1/64	FINAL APPROVAL	G.D.B		MAMARONECK, NEW YORK	
.XX ± .01 ANGLES 0° - 30'	MECH. DES.				
.XXX ± .005	ELECT. DES.				
MATERIAL .051 THICK	CHECKED			COVER PLATE	
ALY 5052-H32	DRAWN	G.D.L		POWER BSP	
FINISH S404					
YEL. IRIDITE					

NOTICE TO PERSONS RECEIVING THIS DRAWING		SIZE	CODE IDENT. NO.	DWG NO.	ISSUE
THE TECHNICAL MATERIEL CORPORATION claims proprietary right in the material disclosed hereon. This drawing is issued in confidence for engineering information only and may not be reproduced or used to manufacture anything shown hereon without permission from THE TECHNICAL MATERIEL CORPORATION to the user. This drawing is loaned for mutual assistance and is subject to recall at any time.		A	82679	MS 7265	Ø
SCALE	1:1	SHEET		OF	

APPLICATION		REVISIONS							
QTY	MODEL USED ON	ASS'Y NO.	LTR	DESCRIPTION	DATE	E.M.N.NO	DRAFT	CHKD	APPD
	AZ102B								

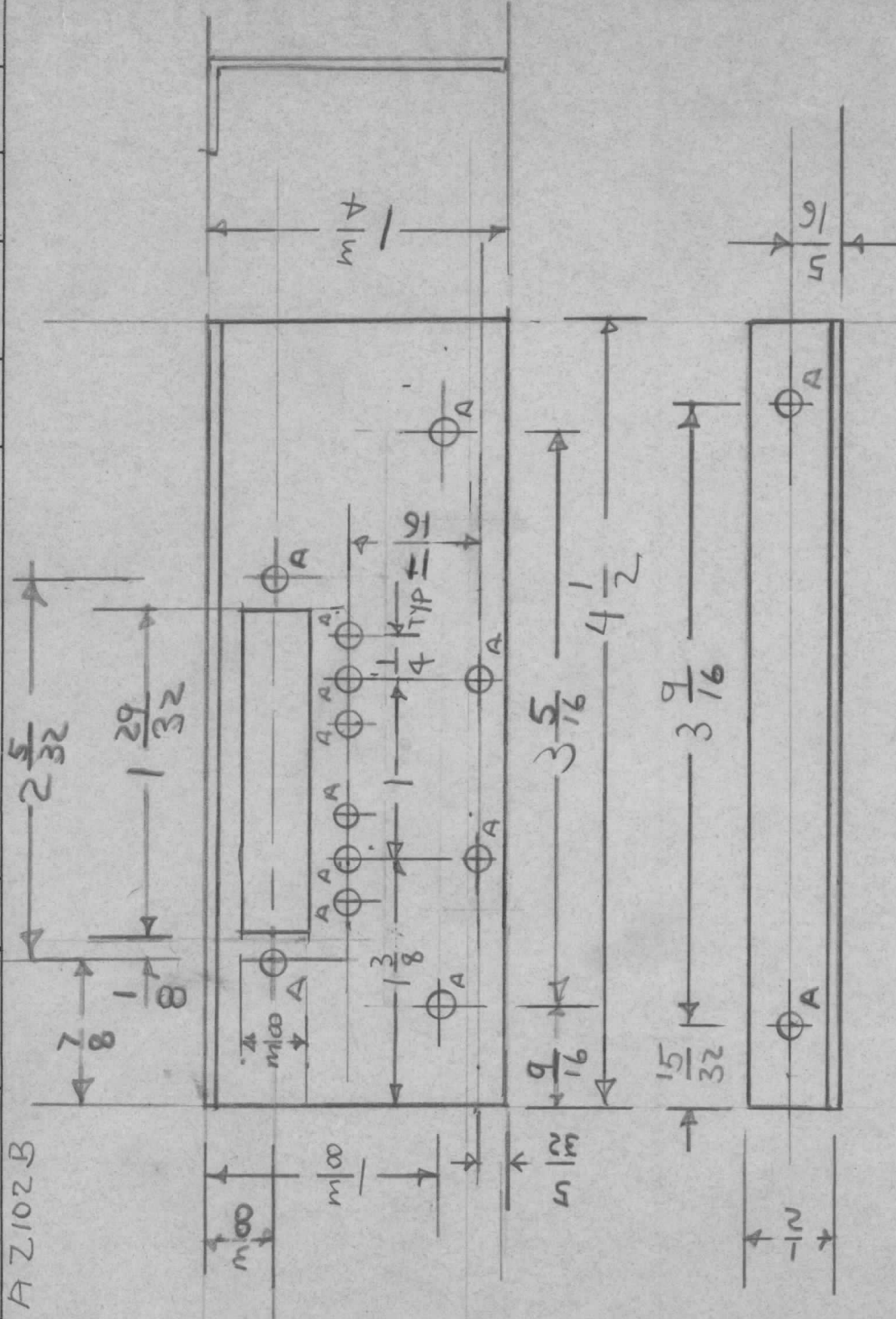

REQ'D ITEM	PART NUMBER	DESCRIPTION	SYM.
LIST OF MATERIAL			
<b>THE TECHNICAL MATERIEL CORP.</b> MAMARONECK, NEW YORK			
FINAL APPROVAL	DATE	BRACKET, CONNECTOR BSP 1,2,3B	
MECH. DES.	DATE		
ELECT. DES.	DATE		
CHECKED	DATE		
DRAWN	DATE		
MATERIAL: 064 FINISH: ALUM.			
VAL IRIDITE			

SIZE	CODE IDENT. NO.	DWG NO.	ISSUE
A	82679	M57275	2
SCALE	SHEET	OF	

**NOTICE TO PERSONS RECEIVING THIS DRAWING**  
 THE TECHNICAL MATERIEL CORPORATION claims proprietary right in the material disclosed hereon. This drawing is issued in confidence for engineering information only and may not be reproduced or used to manufacture anything shown hereon without permission from THE TECHNICAL MATERIEL CORPORATION to the user. This drawing is loaned for mutual assistance and is subject to recall at any time.