

REQ. PER UNIT	USED ON		
	MODEL	ASS'Y. NO.	DATE
2	GPR (S)		1-13-56
2	RTC		1-13-56

MS-788 A

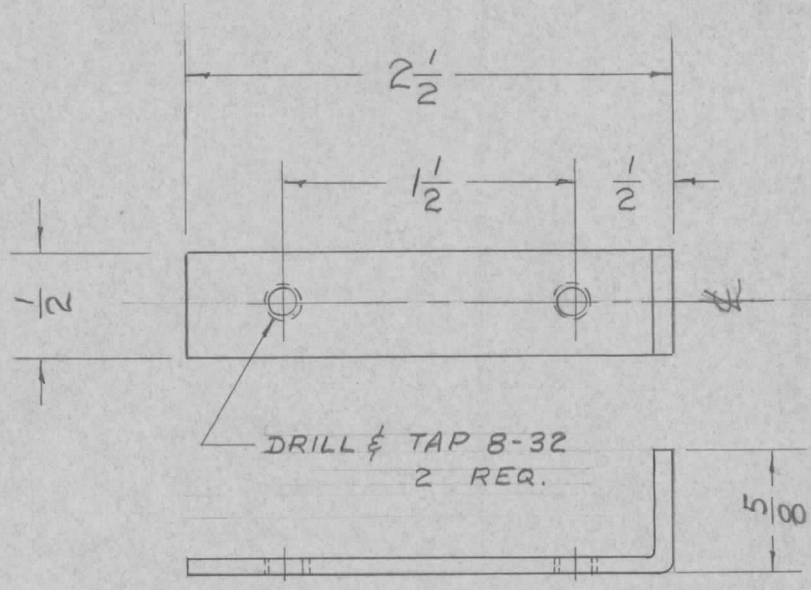

BRASS 8127  
3 x 1/2

ISSUE	ITEM	CHANGED FROM	DATE	CH. NO.	DRAFTS	CHECKER	ENG. APP.	REQ. ITEM	PART NO.	DESCRIPTION	SYMBOL	
										<b>THE TECHNICAL MATERIEL CORP.</b> MAMARONECK. NEW YORK STRAP NUT		
									.081			
									STOCK SIZE			
									ALUMINUM			
									MATERIAL			
A	1	S404 IRIDITE WAS S101 CAUSTIC DIP	12-7 53	1001	JP		EMN					
TOLERANCES			SCALE:					525-H32	—H—	13-13-56	JNO	WDC
DEC. DIM. ±			MAXIMUM ALLOWABLE TOLERANCES HAVE BEEN DETERMINED AND ANY DEVIATIONS WILL BE CAUSE FOR REJECTION. REMOVE ALL BURRS AND SHARP EDGES					TYPE & TEMPER	HEAT TREAT. SPEC.	DRAWN	CHECKED	FINAL APPROVAL
FRAC. DIM. ± YGA								FINISH & SPEC. NO.				
ANGULAR DIM. ±												