

REQ. PER UNIT	USED ON			MS-764	A
	MODEL	ASS'Y. NO.	DATE		
2	TER-3500	A-1378	12-2-55		
2	TER-500	A-1224	10-23-57		

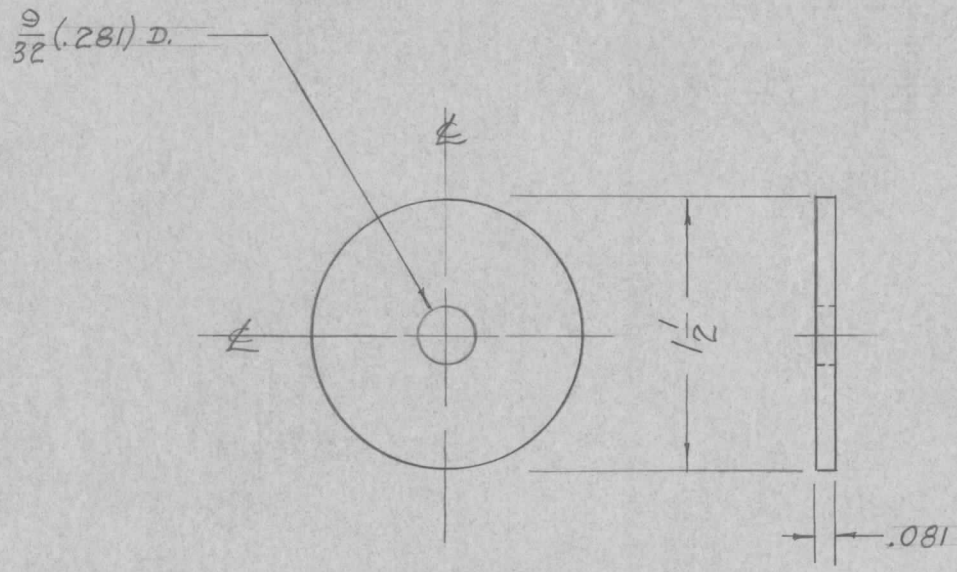

ISSUE	ITEM	CHANGED FROM	DATE	CH. NO.	DRAFTS	CHECKER	ENG. APP.	REQ. ITEM	PART NO.	DESCRIPTION	SYMBOL		
									.081 THICK	THE TECHNICAL MATERIEL CORP. MAMARONECK, NEW YORK			
									STOCK SIZE				
A	1	S404 - IRIDITE WAS S101 - CAUSTIC DIP	12-7 59	1001	P		EMN		ALUMINUM	CONTACT SPARK GAP			
									MATERIAL	TER-3500			
TOLERANCES			SCALE:					525-H3Z	11	13 12-2-55	JADe	APPB	
DEC. DIM. ±			MAXIMUM ALLOWABLE TOLERANCES HAVE BEEN DETERMINED AND ANY DEVIATIONS WILL BE CAUSE FOR REJECTION. REMOVE ALL BURRS AND SHARP EDGES					TYPE & TEMPER		HEAT TREAT. SPEC.	DRAWN	CHECKED	FINAL APPROVAL
FRAC. DIM. ± 1/64								S404 IRIDITE		APPB	WDL	MS-764	A
ANGULAR DIM. ±								FINISH & SPEC. NO.		ELEC. DES. APP.	MECH. DES. APP.		