

| REVISIONS | | | | | | | |
|-----------|-------|------|------|-----|---------------------------------|--------|----------|
| EMN. NO. | DRAFT | CHKD | ZONE | LTR | DESCRIPTION | DATE | APPROVED |
| | GDL | | | | ORIGINAL RELEASE FOR PRODUCTION | 1-5-83 | |

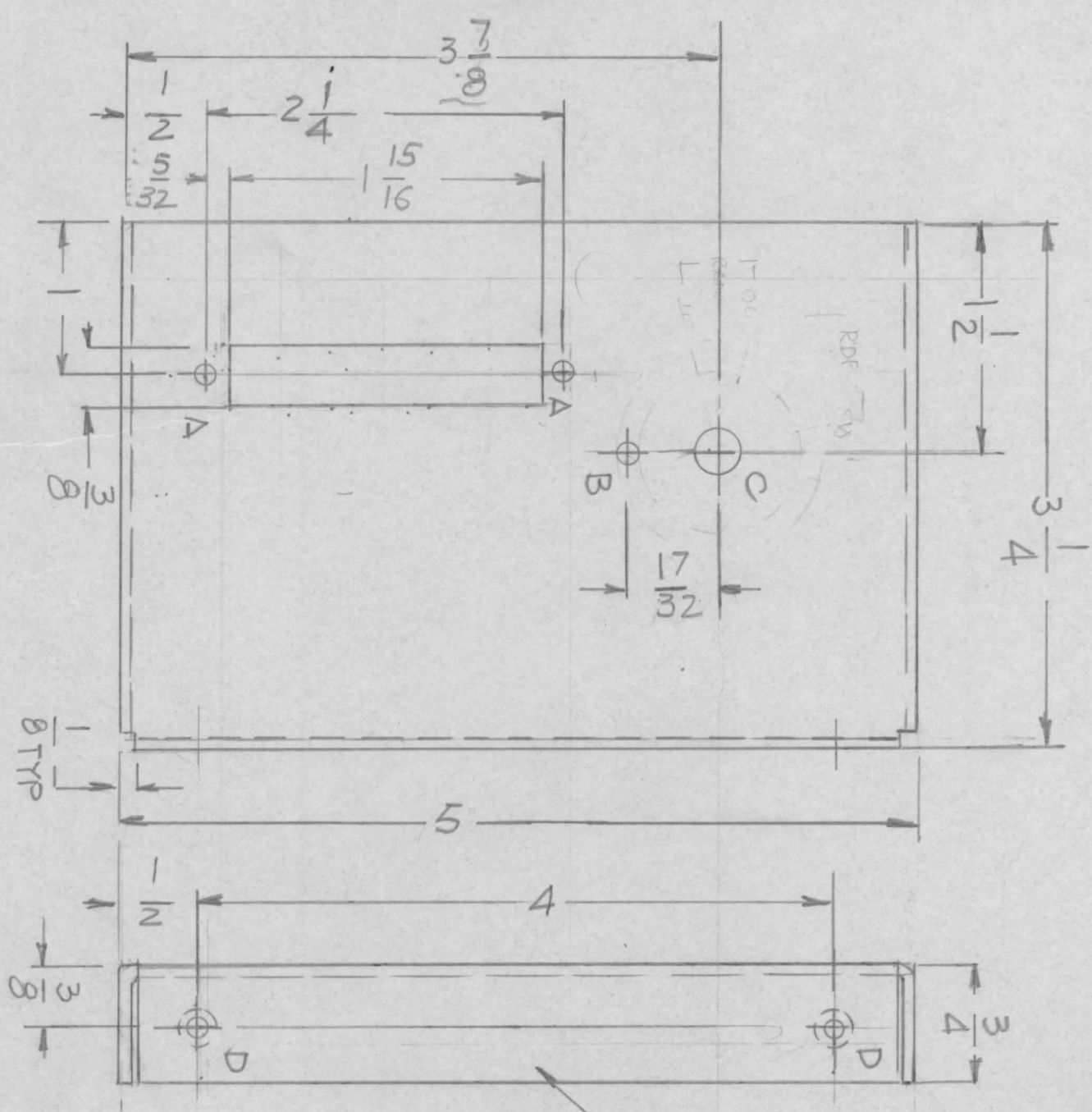

- HOLES
- A - 11/64 DIA 2 REQ'D
 - B - 9/64 DIA
 - C - 13/32 DIA
 - D - .191-.194 DIA 2 REQ'D

| REQ'D | ITEM | PART NUMBER | DESCRIPTION | SYM. |
|-------|------|-------------|-------------|------|
| 2 | 1 | NT129-06324 | NUT ROUND | |

| | | | | | |
|-------------|---|---------------|--------|-----------|--|
| QTY / UNIT | 1 | MODEL USED ON | AX5255 | ASS'Y NO. | |
| APPLICATION | | | | | |
| CODE | | | | | |

| | | |
|---|----------------|--------|
| UNLESS OTHERWISE SPECIFIED DIMENSIONS ARE IN INCHES AND INCLUDE CHEMICALLY APPLIED OR PLATED FINISHES | FINAL APPROVAL | DATE |
| MECH. DES. | G.D.L. | 1-5-83 |
| ELECT. DES. | | |
| CHECKED | | |
| DRAWN | G.D.L. | 8-9-82 |

| | | | |
|------------------------------|-----------------|---------|-------|
| LIST OF MATERIAL | | | |
| THE TECHNICAL MATERIEL CORP. | | | |
| MAMARONECK, NEW YORK | | | |
| BRACKET MTG. SW | | | |
| SIZE | CODE IDENT. NO. | DWG NO. | ISSUE |
| B | 82679 | MS 7096 | |
| SCALE | 1:1 | SHEET | OF |

- UNLESS OTHERWISE SPECIFIED:
1. USE MATERIAL THICKNESS FOR MAXIMUM RADIUS ON ALL BENDS.
 2. ALL ANGULAR BENDS 90 DEGREES.
 3. REMOVE ALL BURRS AND SHARP EDGES.
 4. MOUNT INSERTS AFTER FINISHING.

NOTICE TO PERSONS RECEIVING THIS DRAWING
 THE TECHNICAL MATERIEL CORPORATION claims proprietary right in the material disclosed hereon. This drawing is issued in confidence for engineering information only and may not be reproduced or used to manufacture anything shown hereon without permission from THE TECHNICAL MATERIEL CORPORATION to the user. This drawing is loaned for mutual assistance and is subject to recall at any time.