

REVISIONS						
ZONE	LTR	DESCRIPTION	DATE	E.M.N.NO	DRAFT	CHKD APPD
		DIM. 2.250 WAS 2.500	1-6-80		G.D.L.	

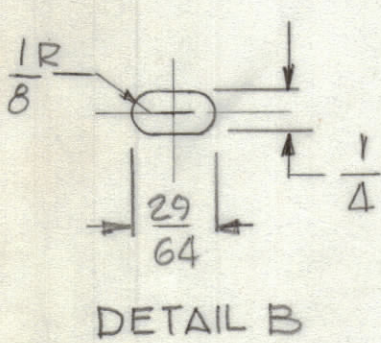
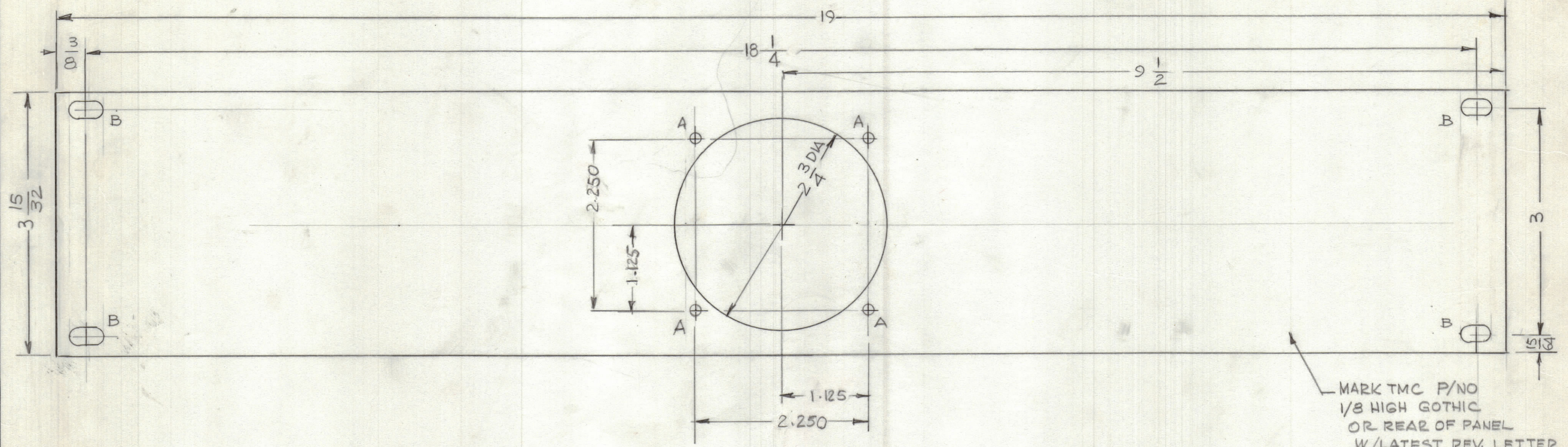

HOLE
 A - 5/32 4 REQ'D
 B - SEE DETAIL 4 REQ'D

FINISH NOTES:
 S404 - YELLOW IRIDITE
 S114 - ZINCO CHROMATE PRIMER } FRONT & EDGES ONLY
 S115 - TMC

MACHINING NOTES
 1- MILL ALL EDGES
 2- PANEL MUST BE FREE OF ALL MACHINING MARKS, GOUGES & SCRATCHES.
 IF NECESSARY, SAND FRONT OF PANEL WITH NO. 120 GRIT SAND PAPER.

GPT-750/E5		
QTY / UNIT	MODEL USED ON	ASS'Y NO.
APPLICATION		
CODE		
NOTICE TO PERSONS RECEIVING THIS DRAWING		
THE TECHNICAL MATERIEL CORPORATION claims proprietary right in the material disclosed hereon. This drawing is issued in confidence for engineering information only and may not be reproduced or used to manufacture anything shown hereon without permission from THE TECHNICAL MATERIEL CORPORATION to the user. This drawing is loaned for mutual assistance and is subject to recall at any time.		

UNLESS OTHERWISE SPECIFIED DIMENSIONS ARE IN INCHES AND INCLUDE CHEMICALLY APPLIED OR PLATED FINISHES

TOLERANCES ON

DECIMALS	FRACTIONS
.X ± .05	± 1/64
.XX ± .01	ANGLES
.XXX ± .005	± 0° -30'

MATERIAL 3/16 THK ALUM 5052-H32

FINISH SEE NOTE

QTY. REQ.	ITEM	PART NO.	DESCRIPTION	SYMBOL
LIST OF MATERIAL				
THE TECHNICAL MATERIEL CORP. MAMARONECK, NEW YORK				
FRONT, PANEL (SWR-1K)				
SIZE	CODE IDENT. NO.	DWG NO.	ISSUE	
C	82679	MS6955	X ₁	
SCALE			SHEET	OF

FINAL APPROVAL	DATE
MECH. DES.	DATE
ELECT. DES.	DATE
CHECKED	DATE
DRAWN G.D.L.	DATE 6-13-79