

APPLICATION

QTY MODEL USED ON ASSY NO.

- TTR-1000J

LTR

REVISIONS

DESCRIPTION

DATE

E.M.N.NO

DRAFT

CHKD

APPD

ORIGINAL RELEASE FOR PRODUCTION

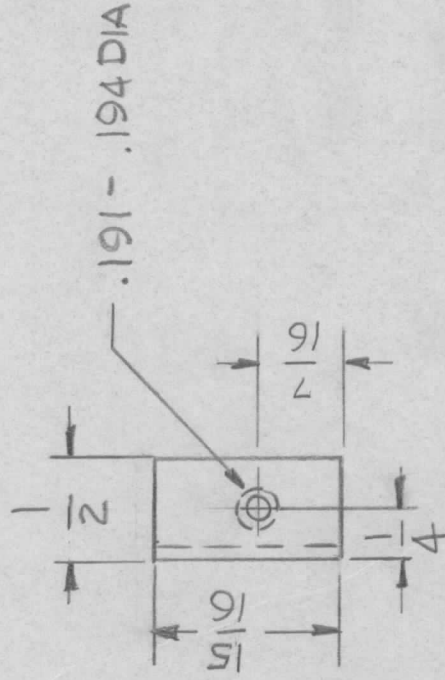
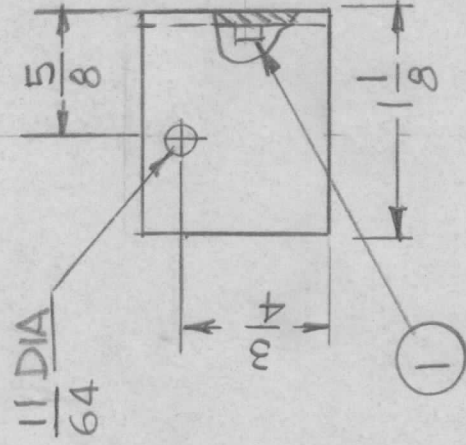

MS 6876-1
(1 REQ'D)

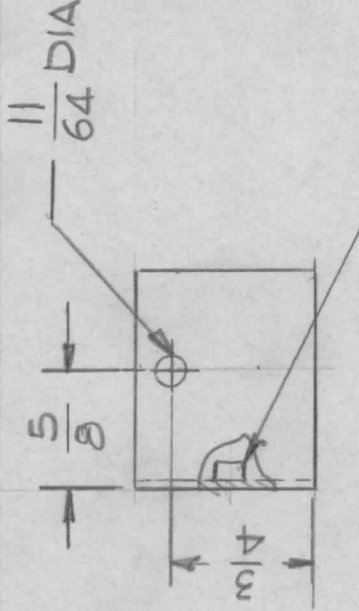
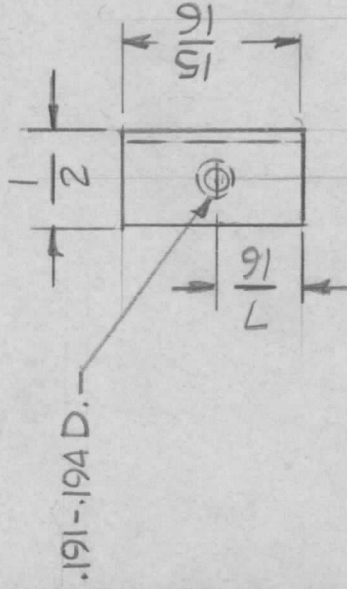

MS 6876-2
(1 REQ'D)

2 1 NT129-0632-4 NUT, ROUND SWAGE

UNLESS OTHERWISE SPECIFIED DIMENSIONS ARE IN INCHES AND INCLUDE CHEMICALLY APPLIED OR PLATED FINISHES

DECIMALS FRACTIONS
X ± .05 TOLS. 1/64
.XX ± .01 ANGLES
.XXX ± .005 0°-30'

MATERIAL .063 THK
AUM. 5052-H32

FINISH S404

YEL. IRIDITE

REQ'D ITEM PART NUMBER DESCRIPTION SYM.

FINAL APPROVAL DATE
MECH. DES. DATE
ELECT. DES. DATE
CHECKED DATE
DRAWN G.D.L. DATE 3-13-78

LIST OF MATERIAL

THE TECHNICAL MATERIEL CORP.
MAMARONECK, NEW YORK

BRACKET, MTG. SW.

NOTICE TO PERSONS RECEIVING THIS DRAWING
THE TECHNICAL MATERIEL CORPORATION claims proprietary right in the material disclosed hereon. This drawing is issued in confidence for engineering information only and may not be reproduced or used to manufacture anything shown hereon without permission from THE TECHNICAL MATERIEL CORPORATION to the user. This drawing is loaned for mutual assistance and is subject to recall at any time.

SIZE CODE IDENT. NO. DWG NO.

A 82679 MS 6876 -

ISSUE

SCALE 1:1 SHEET OF