

REVISIONS					
E.M.N.NO	DRAFT	CHKD	ZONE	LTR	
DESCRIPTION				DATE	APPROVED

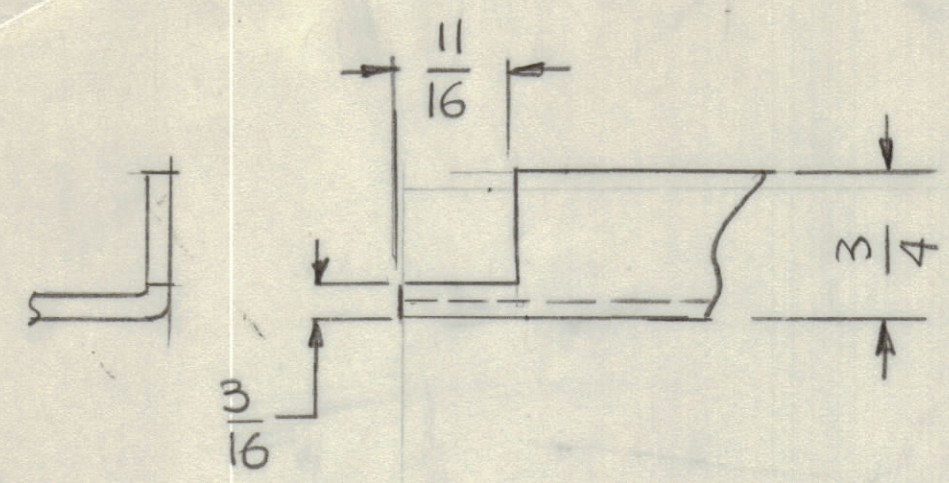

BEND PANEL BEFORE MACHINING
(4 CORNERS)

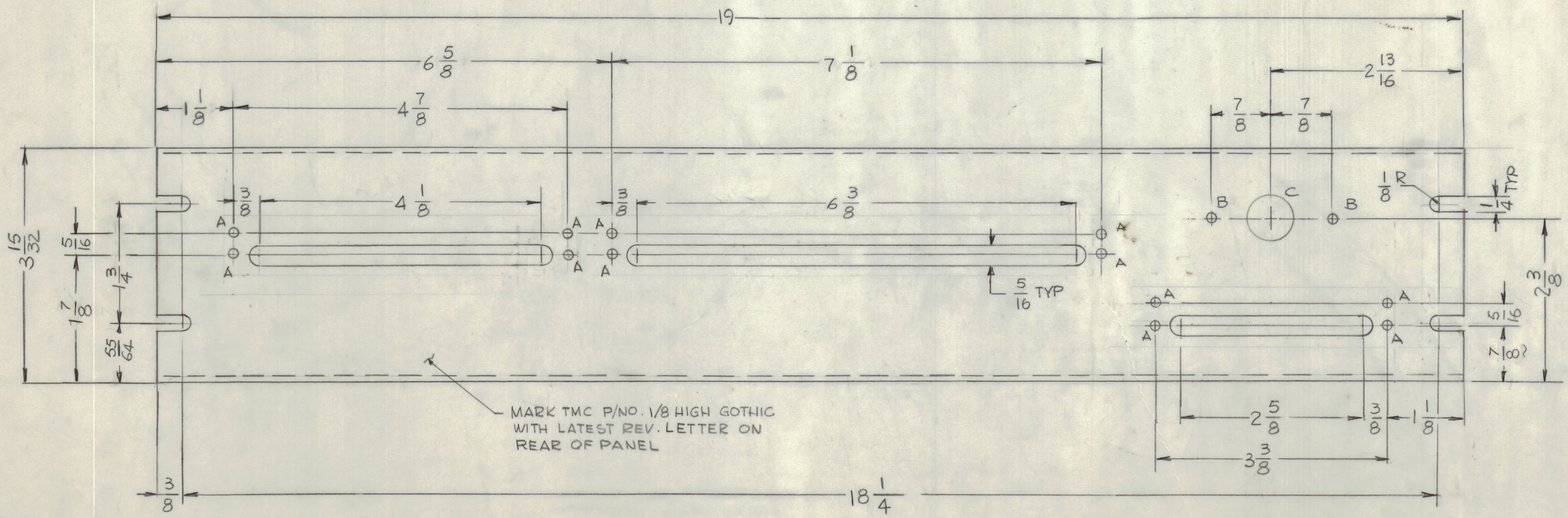

MARK TMC P/NO. 1/8 HIGH GOTHIC
WITH LATEST REV. LETTER ON
REAR OF PANEL

- HOLES
- A - 5/32 DIA 12 REQ
 - B - 11/64 DIA 2 REQ
 - C - 2/32 DIA 1 REQ

MACHINING:

1. MILL ALL EDGES.
2. HOLES MUST BE DRILLED, UNLESS OTHERWISE SPECIFIED.
3. LATERAL BOW OF PANEL MUST BE KEPT TO .031 TOLERANCE.
4. PANEL MUST BE FREE OF ALL MACHINING MARKS, GOUGES AND SCRATCHES. IF NECESSARY, SAND FRONT OF PANEL WITH NO. 120 GRIT SANDPAPER.

REF: LD3066

1	TTR-1KC	AX5217
QTY / UNIT	MODEL USED ON	ASS'Y NO.
	APPLICATION	
	CODE	
<small>NOTICE TO PERSONS RECEIVING THIS DRAWING</small> <small>THE TECHNICAL MATERIEL CORPORATION claims proprietary right in the material disclosed hereon. This drawing is issued in confidence for engineering information only and may not be reproduced or used to manufacture anything shown hereon without permission from THE TECHNICAL MATERIEL CORPORATION to the user. This drawing is loaned for mutual assistance and is subject to recall at any time.</small>		

UNLESS OTHERWISE SPECIFIED
DIMENSIONS ARE IN INCHES
AND INCLUDE CHEMICALLY APPLIED
OR PLATED FINISHES

TOLERANCES ON

DECIMALS FRACTIONS
.X ± .05 ± 1/64
.XX ± .01 ANGLES
.XXX ± .005 ± 0° -30'

MATERIAL .081THK ALUM
3052-H32

FINISH SA04
VEL IRIDITE

QTY. REQ.	ITEM	PART NO.	DESCRIPTION	SYMBOL
LIST OF MATERIAL				
THE TECHNICAL MATERIEL CORP. MAMARONECK, NEW YORK				
INTERFACE RACK PANEL				
FINAL APPROVAL		DATE		
MECH. DES.		DATE		
ELECT. DES.		DATE		
CHECKED		DATE		
DRAWN		DATE		
GDL		12-30-76		
SIZE	CODE	IDENT NO.	DWG NO.	ISSUE
D	82679		MS6767	X
SCALE 1:1				SHEET OF