

4

3

2

1

NOTES:

UNLESS OTHERWISE SPECIFIED:

- 1. USE MATERIAL THICKNESS FOR MAXIMUM RADIUS ON ALL BENDS.
- 2. ALL ANGULAR BENDS 90 DEGREES.
- 3. REMOVE ALL BURRS AND SHARP EDGES.
- 4. MOUNT INSERTS AFTER FINISHING.

MARK TMC PART NUMBER
1/8 HIGH GOTHIC WITH LATEST
REVISION LETTER

OPPOSITE SIDE IDENTICAL

REVISIONS					DATE	APPROVED
E.M.N.NO	DRAFT	CHKD	ZONE	LTR	DESCRIPTION	
	RF			X	EXP RELEASE	1-27-71
	W			Ø	ORIGINAL RELEASE FOR PRODUCTION	6/18/71 <i>R.F.G.</i>

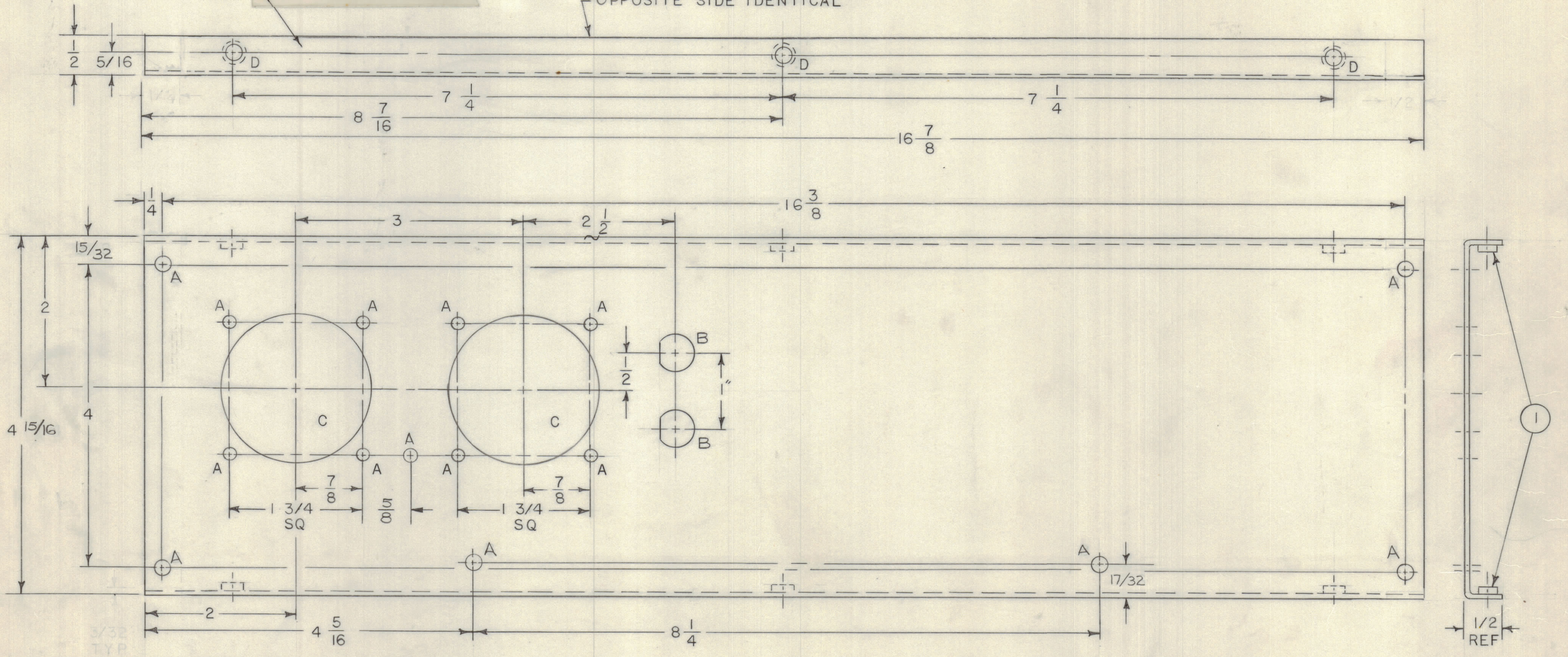

HOLE	DESCRIPTION	REQD
A	11/64 DIA	15
B	SEE DETAIL	2
C	2 1/16 DIA	2
D	.191-.194 DIA	6

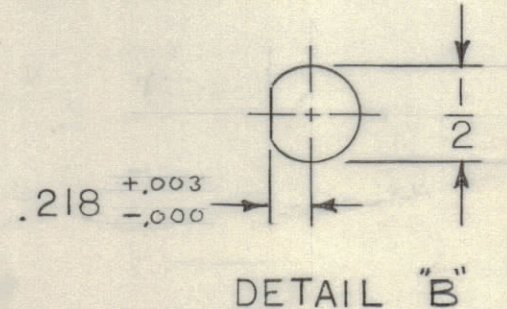

1	AX5130	
QTY / UNIT	MODEL USED ON	ASS'Y NO.
APPLICATION		
CODE		

NOTICE TO PERSONS RECEIVING THIS DRAWING
 THE TECHNICAL MATERIEL CORPORATION claims proprietary right in the material disclosed hereon. This drawing is issued in confidence for engineering information only and may not be reproduced or used to manufacture anything shown hereon without permission from THE TECHNICAL MATERIEL CORPORATION to the user. This drawing is loaned for mutual assistance and is subject to recall at any time.

REF. LD 2469

UNLESS OTHERWISE SPECIFIED
 DIMENSIONS ARE IN INCHES
 AND INCLUDE CHEMICALLY APPLIED
 OR PLATED FINISHES

TOLERANCES ON

DECIMALS	FRACTIONS
.X ± .05	± 1/64
.XX ± .01	ANGLES
.XXX ± .005	± 0° -30'

6	1	NT-129-0632-4	NUT, ROUND, SWAGE TYPE	D
QTY. REQ.	ITEM	PART NO.	DESCRIPTION	SYMBOL
F BUDETTI LIST OF MATERIAL				
FINAL APPROVAL		DATE	THE TECHNICAL MATERIEL CORP.	
<i>S.B.</i>		6/18/71	MAMARONECK, NEW YORK	
MECH. DES.		DATE	PLATE, REAR	
<i>A. Petronica</i>		6-18-71		
ELECT. DES.		DATE		
<i>R. Forlano</i>		6-18-71		
CHECKED		DATE		
DRAWN		DATE		
R FORLANO		1-27-71		
MATERIAL .064 THK ALUM 5052-H32			SIZE	CODE IDENT NO.
FINISH S404 YEL IRIDITE			C	82679
			DWG NO.	MS 6204
			ISSUE	Ø
SCALE			SHEET 1 OF 1	

4

3

2

1

MS 6204