

IF IT IS FOUND DESIRABLE TO CHANGE ANY TOLERANCE OR OTHER DETAIL SPECIFIED ON THIS DRAWING NOTIFY THE PURCHASER PROMPTLY.

MAXIMUM ALLOWABLE TOLERANCES HAVE BEEN DETERMINED AND DEVIATIONS WILL BE CAUSE FOR REJECTION. REMOVE ALL BURRS AND SHARP EDGES

MS-690 A

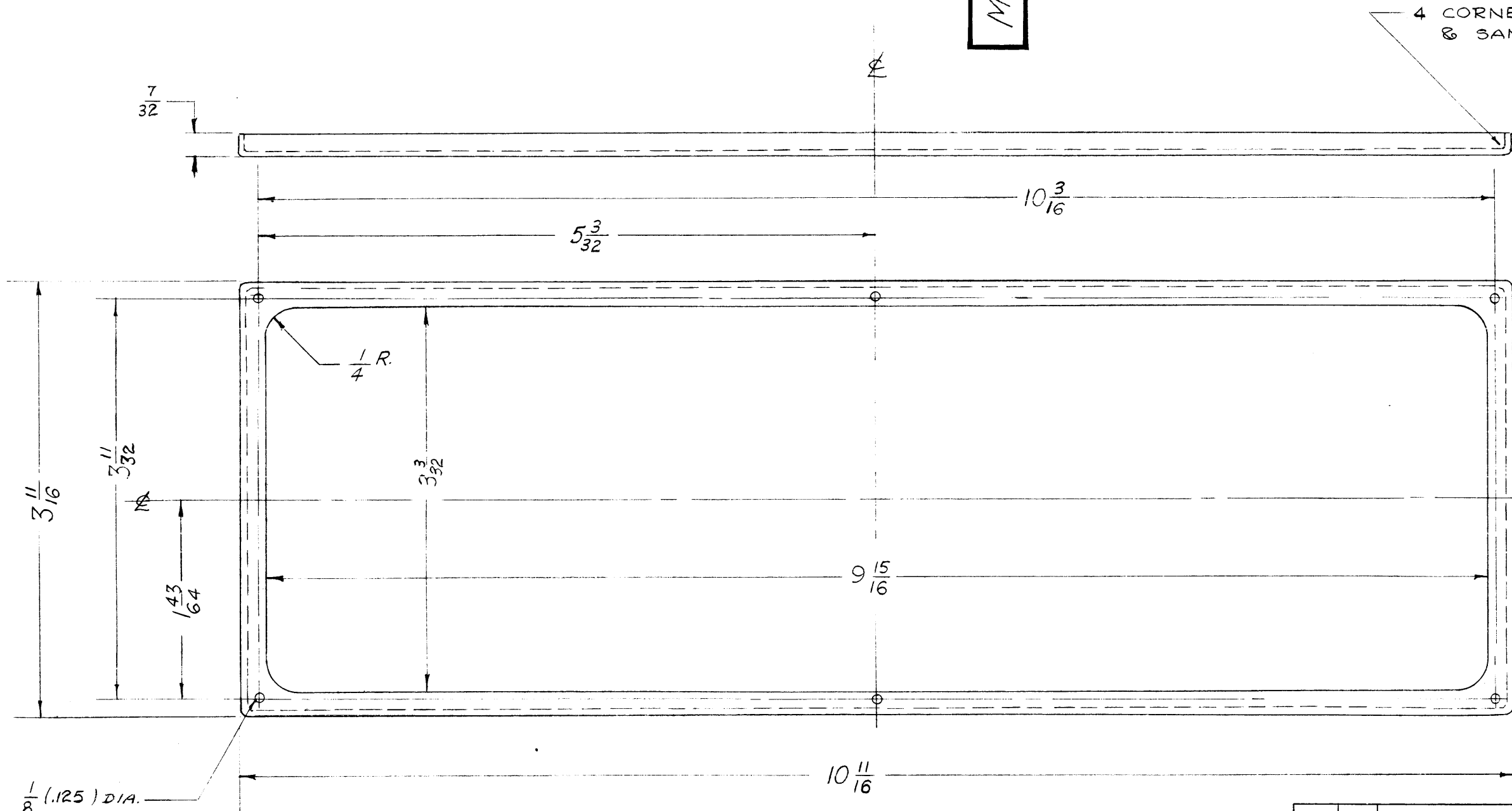

NOTICE TO PERSONS RECEIVING THIS DRAWING

THE TECHNICAL MATERIEL CORPORATION claims proprietary right in the material disclosed hereon. This drawing is issued in confidence for engineering information only and may not be reproduced or used to manufacture anything shown hereon without permission from THE TECHNICAL MATERIEL CORPORATION to the user. This drawing is loaned for mutual assistance and is subject to recall at any time.

Property of:
THE TECHNICAL MATERIEL CORPORATION
 MAMARONECK, NEW YORK

FINISH NOTE:
 S-404 YELLOW IRIDITE
 S-114-ZINC CHROMATE PRIMER
 S-115-SMOOTH GRAY ENAMEL

REQ.	ITEM	PART NO.	DESCRIPTION	SYMBOL
		.040 THK.	THE TECHNICAL MATERIEL CORP. MAMARONECK, NEW YORK	
		STOCK SIZE		
	ALUMINUM	#	BEZEL, FRONT PANEL	
		MATERIAL	WEIGHT PER PC.	
		52 S - H32	GPT	
		TYPE & TEMPER		
		#		
		HEAT TREAT. SPEC.		
		SEE NOTE		
		FINISH & SPEC. NO.		

A	1	S-404 WAS S-101	12/1/58	1001	AL		EMN
ISSUE	ITEM	CHANGED FROM	DATE	CN. NO.	DRAFTS	CHECKER	ENG. APP.
TOLERANCES		SCALE:					
ALL OTHERS	DEC. DIM. ±	DRILL, PUNCH, COMMERCIAL STOCK					
	FRAC. DIM. ±	SIZES AND MANUFACTURERS					
	ANGULAR DIM. ±	TOLERANCES ARE NOT INCLUDED.					

1	RTF-2	F/P		11-19-58
1	RTF			9-22-55
REQ. PER UNIT	MODEL	PROJECT NO.	ASS'Y. NO.	DATE
USED ON				