

IF IT IS FOUND DESIRABLE TO CHANGE ANY TOLERANCE OR OTHER DETAIL SPECIFIED ON THIS DRAWING NOTIFY THE PURCHASER PROMPTLY.
 MAXIMUM ALLOWABLE TOLERANCES HAVE BEEN DETERMINED AND DEVIATIONS WILL BE CAUSE FOR REJECTION. REMOVE ALL BURRS AND SHARP EDGES.

NOTICE TO PERSONS RECEIVING THIS DRAWING

THE TECHNICAL MATERIEL CORPORATION claims proprietary right in the material disclosed herein. This drawing is issued in confidence for engineering information only and may not be reproduced or used to manufacture anything shown herein without permission from THE TECHNICAL MATERIEL CORPORATION to the user. This drawing is loaned for mutual assistance and is subject to recall at any time.

Property of:
 THE TECHNICAL MATERIEL CORPORATION
 MAMARONECK, NEW YORK

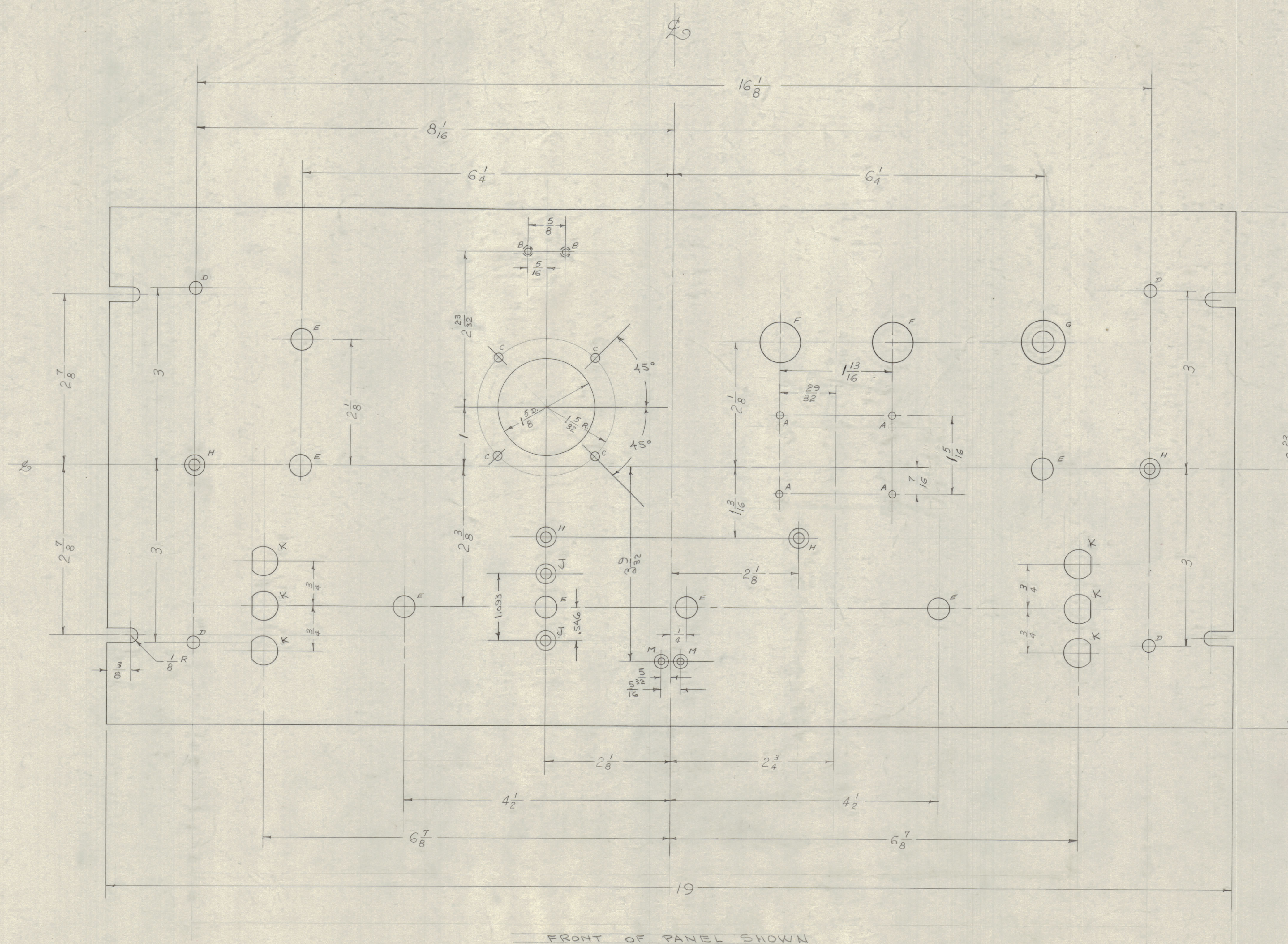

Symbol	Description	Quantity	Holes Req.
A	#47 (OTS) DRILL	4	"
B	DRILL & TAP A-40	2	"
C	#11 (.171) D.	4	"
D	#1 (.218) D.	4	"
E	#25 (.390) D.	7	"
F	#45 (.703) D.	2	"
G	#25 DRILL 3/4 C BORE 1/16 DEEP	1	"
H	SEE DETAIL #8 FHS	4	"
J	#11 " " #6 FHS	2	"
K	1/2" D HOLE	6	"
M	SEE DETAIL #4 FHS	2	"

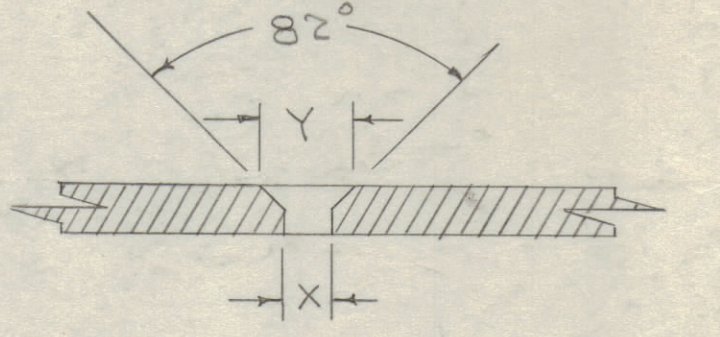

Dim	#4 FHS	#6 FHS	#8 FHS
X	#31 (.120)	#27 (.144)	#18 (.169)
Y	.230	.284	.337

Tol. ±.005

DIH. SHOWN ARE AFTER PAINTING
 DETAIL FOR H - J & M HOLES.

NOTE: FINISH
 S-404 IRIDITE
 S-114 ZINC CHROMATE PRIMER
 S-115 SMOOTH GRAY ENAMEL
 OR - PRIME & PAINT TO CUSTOMERS SPECIFICATION.

FRONT OF PANEL SHOWN

ISSUE	ITEM	CHANGED FROM	DATE	CN. NO.	DRAFTS	CHECKER	ENG. APP.
B	1	S-404 VEL. IRIDITE WAS	12/6/57	1001	AB	EMN	
A	2	S-101 CAUSTIC DIP					
A	1	2 HOLES MOVED	8-8-55	1	AB	WOL	
A	1	2 HOLES WERE #50 DR					

TOLERANCES
 DEC. DIM. ±.005
 FRAC. DIM. ± 1/64
 ANGULAR DIM. ±

DRILL PUNCH, COMMERCIAL STOCK SIZES AND MANUFACTURERS TOLERANCES ARE NOT INCLUDED.

REF. DNG. LD-225

REQ. PER UNIT	MODEL	PROJECT NO.	ASSY. NO.	DATE	SYMBOL
1	FSS			6-23-55	MS-659 B

REQ. ITEM	PART NO.	DESCRIPTION	SYMBOL
	3/16 THK.	THE TECHNICAL MATERIEL CORP. MAMARONECK, NEW YORK	
	ALUMINUM -H-	PANEL, FRONT	
	MATERIAL	WEIGHT PER PC.	FSS
	24S T3		
	TYPE & TEMPER		
	HEAT TREAT. SPEC.		
	SEE NOTE		
	FINISH & SPEC. NO.		