

APPLICATION

REVISIONS

QTY	MODEL USED ON	ASS'Y NO.	LTR	DESCRIPTION	DATE	E.M.N.NO	DRAFT	CHKD	APPD
1	SPER-1F3		Ø	ORIG. RELEASE FOR PROD.	11-27-68		R.G.		

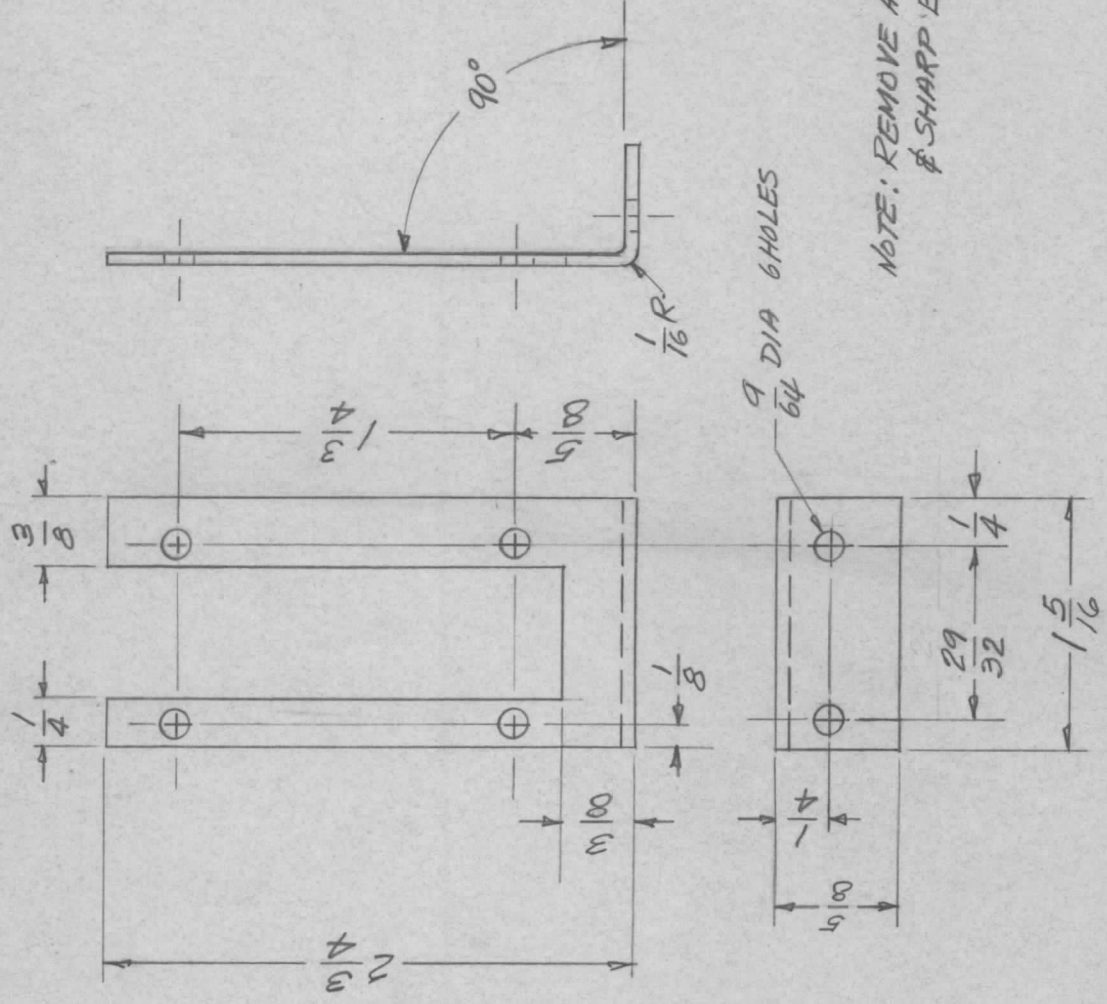

UNLESS OTHERWISE SPECIFIED DIMENSIONS ARE IN INCHES AND INCLUDE CHEMICALLY APPLIED OR PLATED FINISHES		REQ'D ITEM	PART NUMBER	DESCRIPTION	SYM.
DECIMALS X ± .05 .XX ± .01 .XXX ± .005		ANGER		LIST OF MATERIAL	
FRACTIONS 1/64		FINAL APPROVAL <i>J. Anger</i>	DATE 11/27/68	THE TECHNICAL MATERIEL CORP.	
ANGLES 0°-30°		MECH. DES. <i>J. Anger</i>	DATE 11/29/68	MAMARONECK, NEW YORK	
MATERIAL .051 THICK		ELECT. DES. <i>J. Anger</i>	DATE 11/29/68	BRACKET, RELAY MOUNTING	
5052-H32 ALUMINUM		CHECKED	DATE 11/20/68		
FINISH S404 IRIDITE-14		DRAWN <i>J. Anger</i>			
2 AL COAT					
NOTICE TO PERSONS RECEIVING THIS DRAWING		SIZE	CODE IDENT. NO.	DWG NO.	ISSUE
THE TECHNICAL MATERIEL CORPORATION claims proprietary right in the material disclosed hereon. This drawing is issued in confidence for engineering information only and may not be reproduced or used to manufacture anything shown hereon without permission from THE TECHNICAL MATERIEL CORPORATION to the user. This drawing is loaned for mutual assistance and is subject to recall at any time.		A	82679	MS 5445	Ø
		SCALE	1:1	SHEET	1 OF 1