

REVISIONS						
ZONE	LTR	DESCRIPTION	DATE	E.M.N.NO	DRAFT	CHKD APPD
	X2	REDRAWN W/O CHANGE	11-22-67	+	HG	MS
	Ø	ORIGINAL RELEASE FOR PRODUCTION	2-19-69		RG	MS

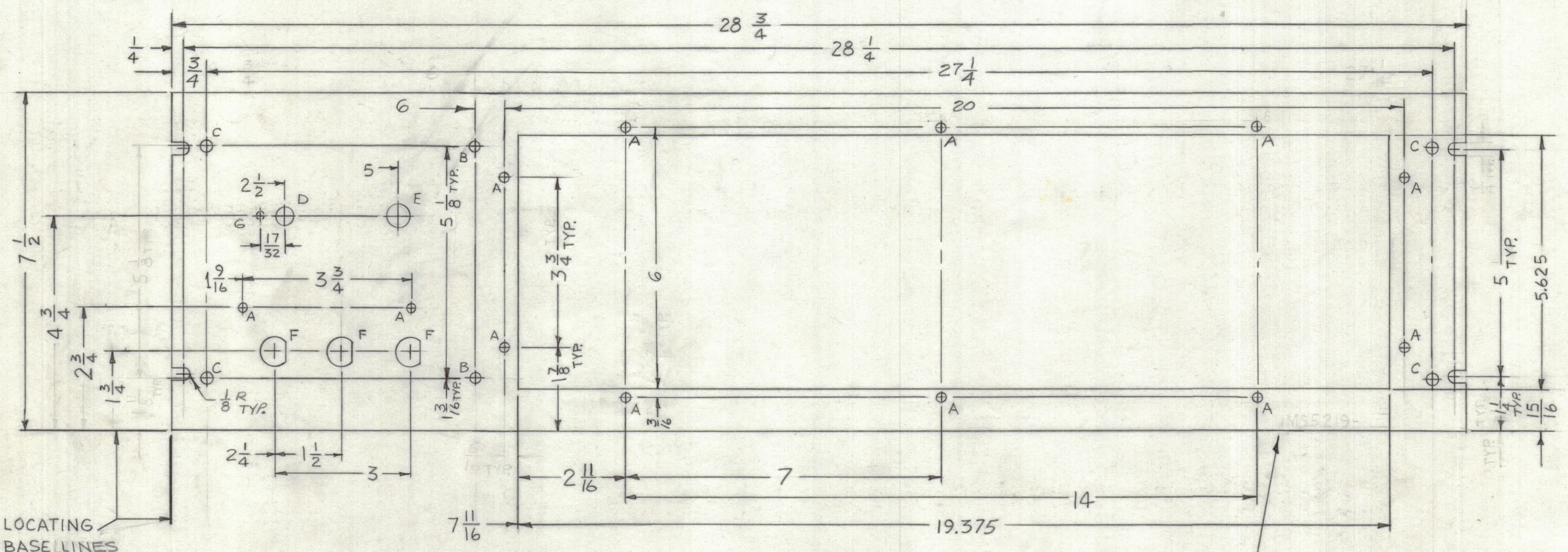

FRONT VIEW

MARK TMC P/N (MS5219- ) 1/8 HIGH GOTHIC W/LATEST REV. LETTER, ON REAR OF PANEL

HOLE	DESCRIPTION	REQ
A	11/64 DIA.	12
B	13/64 DIA.	2
C	15/64 DIA.	4
D	3/8 DIA.	1
E	1/2 DIA.	1
F	SEE DETAIL	3
G	1/8 DIA. C'BORE 1/8 DEEP FROM REAR	1

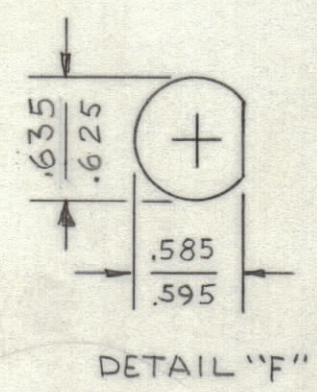

TMC P/N	DESCRIPTION	USED ON
MS5219-1	AS SHOWN	GPT-10KRL GPT-40KEL
MS5219-2	OMIT 'E' HOLE	GPT-10KLF

**MACHINING:**

- MILL ALL EDGES.
- HOLES MUST BE DRILLED, UNLESS OTHERWISE SPECIFIED.
- LATERAL BOW OF PANEL MUST BE KEPT TO .031 TOLERANCE.
- PANEL MUST BE FREE OF ALL MACHINING MARKS, GOUGES AND SCRATCHES. IF NECESSARY, SAND FRONT OF PANEL WITH NO. 120 GRIT SANDPAPER.

**FINISH NOTES:**

- S404 - IRIDITE 14-2 AL-COAT.
- S114 - ZINC CHROMATE PRIMER } FRONT AND
- S115 - SMOOTH GRAY ENAMEL } EDGES ONLY

QTY / UNIT	SEE CHART	ASS'Y NO.
	MODEL USED ON	
APPLICATION		
CODE	S401-451	
A		

NOTICE TO PERSONS RECEIVING THIS DRAWING  
 THE TECHNICAL MATERIEL CORPORATION claims proprietary right in the material disclosed hereon. This drawing is issued in confidence for engineering information only and may not be reproduced or used to manufacture anything shown hereon without permission from THE TECHNICAL MATERIEL CORPORATION to the user. This drawing is loaned for mutual assistance and is subject to recall at any time.

REF: LD2256 (REF CHART)

QTY. REQ.	ITEM	PART NO.	DESCRIPTION	SYMBOL
	F. BUDETTI		LIST OF MATERIAL SK060040-LD2200-MS2201	
FINAL APPROVAL		DATE	<b>THE TECHNICAL MATERIEL CORP.</b> MAMARONECK, NEW YORK  <b>PANEL, FRONT, EXC. DRAWER</b>	
MECH. DES.		DATE		
ELECT. DES.		DATE		
CHECKED		DATE		
DRAWN		DATE		
TOLERANCES ON				
DECIMALS		FRACTIONS		
.X ± .05		± 1/64		
.XX ± .01		ANGLES		
.XXX ± .005		± 0° -30'		
MATERIAL 1/8 ALUMINUM				
2024-T3				
FINISH		SEE NOTES		
SCALE	1:2	CODE IDENT. NO.	DWG NO.	ISSUE
		C 82679	MS5219	Ø
SHEET			OF	