

IF IT IS FOUND DESIRABLE TO CHANGE ANY TOLERANCE OR OTHER DETAIL SPECIFIED ON THIS DRAWING NOTIFY THE PURCHASER PROMPTLY.

MAXIMUM ALLOWABLE TOLERANCES HAVE BEEN DETERMINED AND DEVIATIONS WILL BE CAUSE FOR REJECTION. REMOVE ALL BURRS AND SHARP EDGES

MS-522 A

REQ  
PER  
UNIT

USED ON

REQ PER UNIT	MODEL	PROJECT NO.	ASS'Y. NO.	DATE
2	KS-85X	J-227	A-742	4-27-54

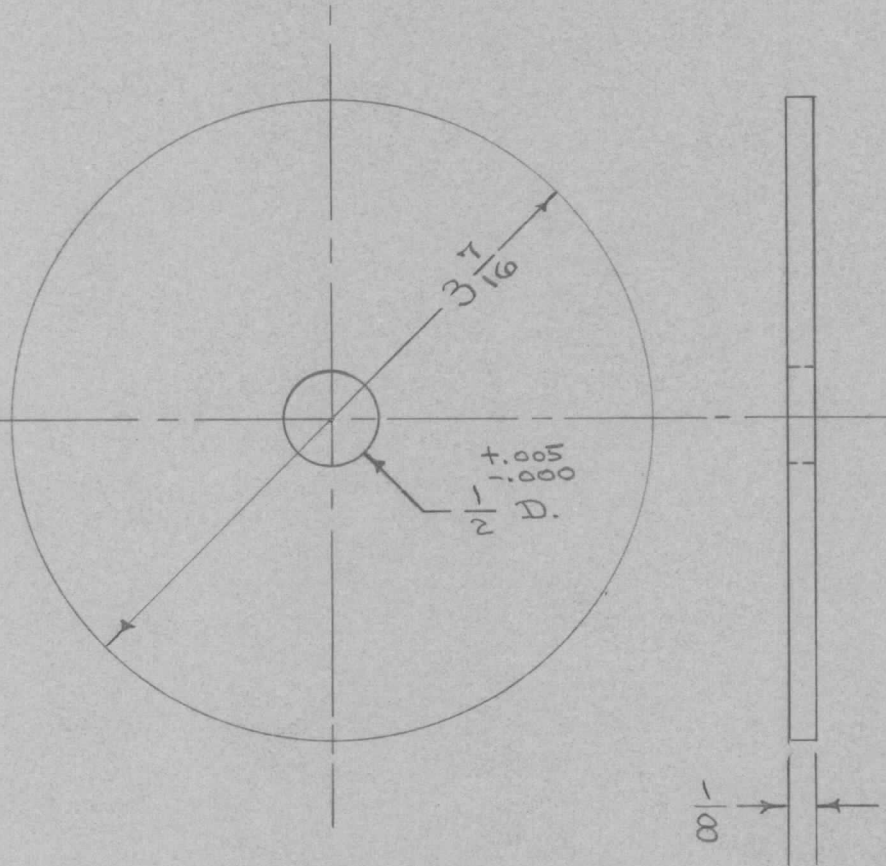

REQ.	ITEM	PART NO.	DESCRIPTION	SYMBOL
		Y8 THICK	THE TECHNICAL MATERIEL CORP. MAMARONECK, NEW YORK	
		STOCK SIZE		
	ALUMINUM	— II —	SIDE PLATE, REEL	
	MATERIAL	WEIGHT PER PC.		
		2A S-T 3		
		TYPE & TEMPER	C.D.D. 4-27-54	WE
		HEAT TREAT. SPEC.	DRAWN	ELEC. DES. APP. MECH. DES. APP.
		FINISH & SPEC. NO.	JAD	WE
			CHECKED	FINAL APPROVAL
				MS-522 A

A	1	S404 - IRIDITE WAS S101 - CAUSTIC DIP	12-7 59	1001	P	EMN	
ISSUE	ITEM	CHANGED FROM	DATE	CN. NO.	DRAFTS	CHECKER	ENG. APP.
TOLERANCES			SCALE				
ALL OTHERS	DEC. DIM. $\pm 1/64$ FRAC. DIM. $\pm .005$ ANGULAR DIM. $\pm$		DRILL, PUNCH, COMMERCIAL STOCK SIZES AND MANUFACTURERS TOLERANCES ARE NOT INCLUDED.				