

IF IT IS FOUND DESIRABLE TO CHANGE ANY TOLERANCE OR OTHER DETAIL SPECIFIED ON THIS DRAWING NOTIFY THE PURCHASER PROMPTLY.

MS-521

MAXIMUM ALLOWABLE TOLERANCES HAVE BEEN DETERMINED AND DEVIATIONS WILL BE CAUSE FOR REJECTION. REMOVE ALL BURRS AND SHARP EDGES

| REQ. PER. UNIT | USED ON | | | |
|----------------|---------|-------------|------------|---------|
| | MODEL | PROJECT NO. | ASS'Y. NO. | DATE |
| 1 | KS-85-X | J-227 | A-500 | 4-26-54 |

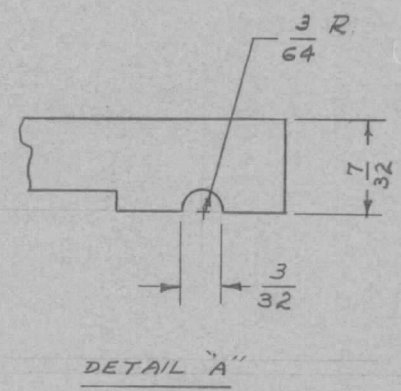
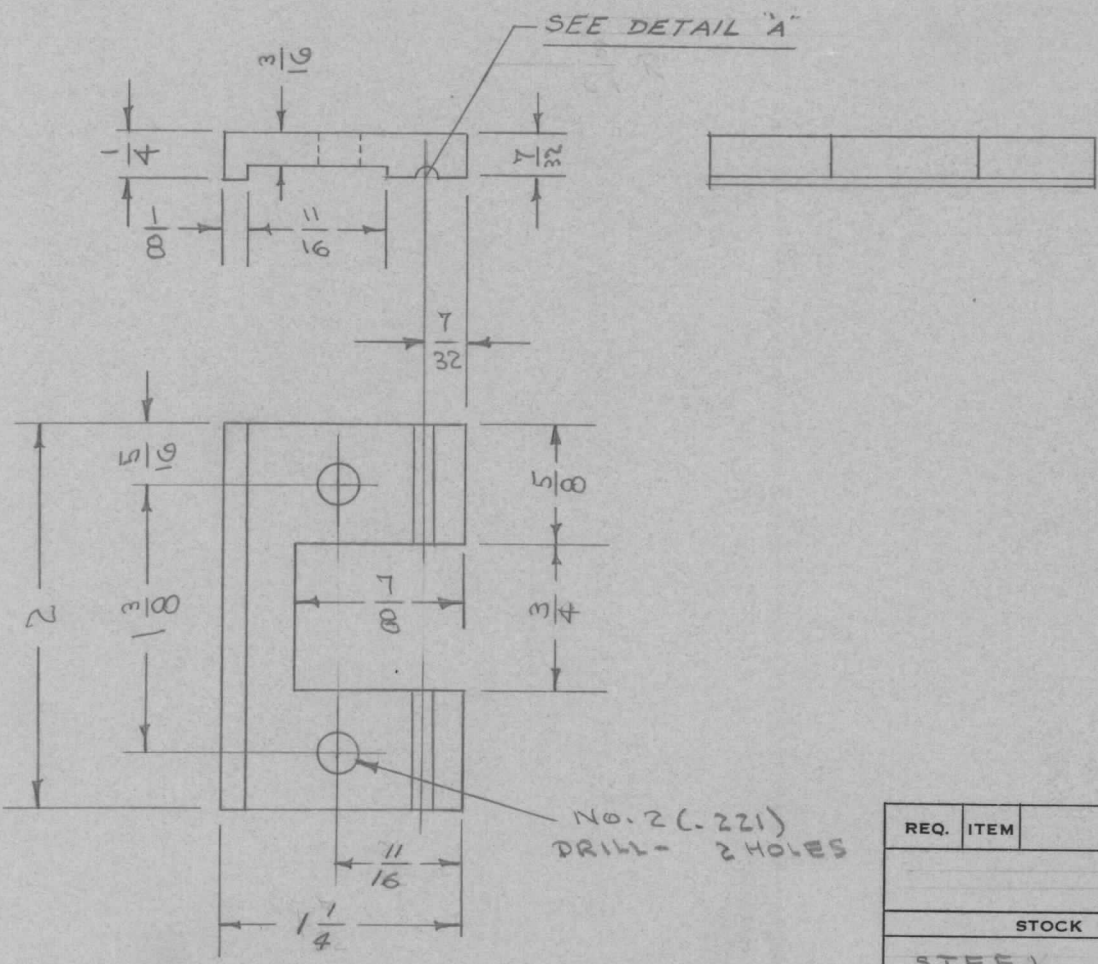

| REQ. | ITEM | PART NO. | DESCRIPTION | SYMBOL |
|------|------|--------------------|---|---------------------------------|
| | | | THE TECHNICAL MATERIEL CORP. MAMARONECK, NEW YORK | |
| | | STEEL | CLAMP - MOVABLE | |
| | | MATERIAL | WEIGHT PER PC. | |
| | | TYPE & TEMPER | C.D.D. 4-26-54 | |
| | | HEAT TREAT. SPEC. | DRAWN | ELEC. DES. APP. MECH. DES. APP. |
| | | FINISH & SPEC. NO. | CHECKED | FINAL APPROVAL |
| | | | MS-521 | |

| ISSUE | ITEM | CHANGED FROM | DATE | CN. NO. | DRAFTS | CHECKER | ENG. APP. |
|------------|--|--------------|---|---------|--------|---------|-----------|
| TOLERANCES | | | SCALE | | | | |
| ALL OTHERS | DEC. DIM. ± FRAC. DIM. ± 1/64 ANGULAR DIM. ± | | DRILL, PUNCH, COMMERCIAL STOCK SIZES AND MANUFACTURERS TOLERANCES ARE NOT INCLUDED. | | | | |