

HOLES:

A. 1/4 DIA. (11 REQ.)

B- DELETED

C- 1/4 X 1/2 SLOT (1 REQ.)

REQ. PER UNIT	USED ON			MS5052	A
	MODEL	ASS'Y. NO.	DATE		
1	TLAA-2.5K	AS128	8-26-66		

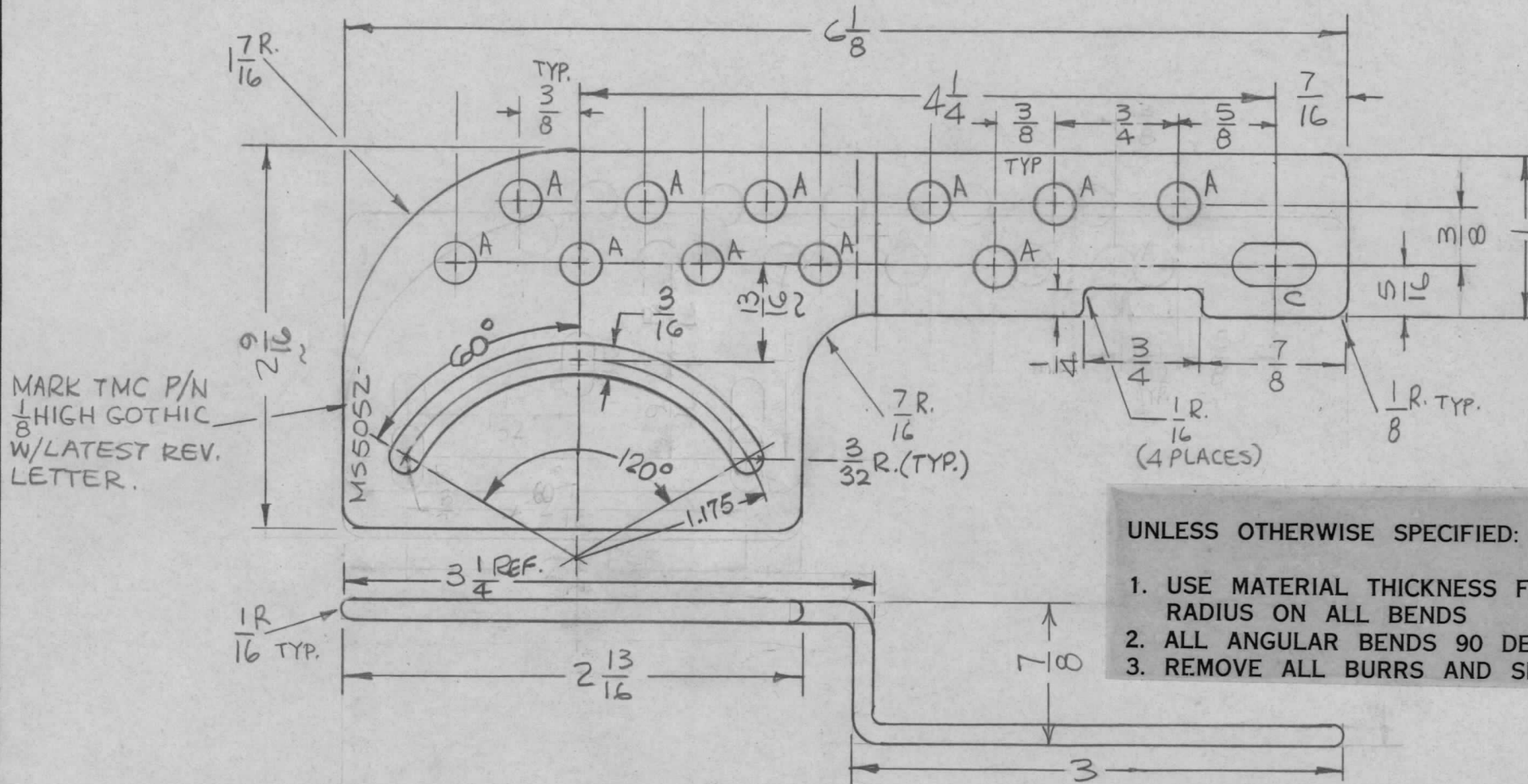

- UNLESS OTHERWISE SPECIFIED:
1. USE MATERIAL THICKNESS FOR MAXIMUM RADIUS ON ALL BENDS
 2. ALL ANGULAR BENDS 90 DEGREES
 3. REMOVE ALL BURRS AND SHARP EDGES

A	CHGD. 3 SLOTTED HOLES TO CIRCULAR SLOT	3-2-67	17886	HEA	WFB	WFB	REQ. ITEM	PART NO.	F. BUDETTI	DESCRIPTION	SYMBOL	
Ø	ORIGINAL RELEASE FOR PRODUCTION	11-11-66	44	WFB		HEA	1/8 THICK		THE TECHNICAL MATERIEL CORP. MAMARONECK, NEW YORK			
X/	NOTCH WAS 3/16 X 1/2	11/10/66	X1	HEA		WFB	STOCK SIZE		STRAP, ELECTRICAL			
X	EXP. RELEASE	8-26-66	X	WFB		HEA	ALUMINUM					
SYM	DESCRIPTION	DATE	CH. NO.	DRAFTS	CHECKER	ENG. APP.	MATERIAL					
UNLESS OTHERWISE SPECIFIED DIMENSIONS ARE IN INCHES AND INCLUDE CHEMICALLY APPLIED OR PLATED FINISHES		SCALE		1			5052-H32		WFB	WFB	WFB	
DECIMALS .X ± .05 .XX ± .01 .XXX ± .005		FRACTIONS ± 1/64 ANGLES ± 0° 30'		CODE A		TYPE & TEMPER S245 SILVER PLATE S423 SILVER KOTE		HEAT TREAT. SPEC.		DRAWN WFB	CHECKED WFB	FINAL APPROVAL WFB
TOLERANCES						FINISH & SPEC. NO.		ELEC. DES. APP.		MECH. DES. APP.		
										MS5052 A		