

| | | | | |
|---------------|----------|------------|---------|----------|
| REQ. PER UNIT | USED ON | | | MS5037 Q |
| | MODEL | ASS'Y. NO. | DATE | |
| 1 | TLAA-25K | AS128 | 8-11-66 | |

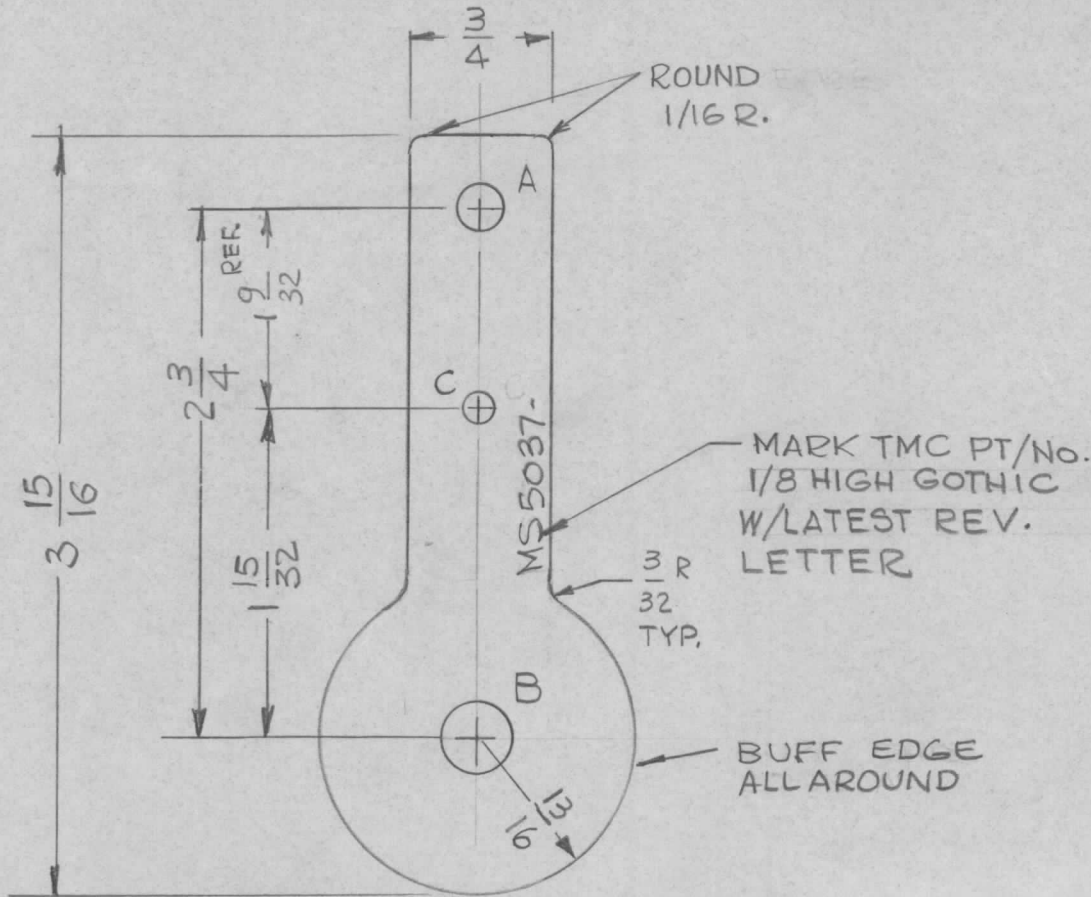

| HOLE | DESCRIPTION | REQ. |
|------|-------------|------|
| A | 1/4 DIA. | 1 |
| B | 13/32 DIA. | 1 |
| C | 11/64 DIA. | 1 |

- NOTE -
ALL EDGES TO BE 1/32 R.

| | | | | | | |
|---|---------------------------------|---|---------|--------|---------|-----------|
| Q | ORIGINAL RELEASE FOR PRODUCTION | 11.11.66 | WHD | File | | |
| X3 | "BUFF" NOTE ADDED | 8-24-66 | JBC | QCB | | |
| X2 | "B" HOLE WAS 3/8 DIA | 8-18-66 | JBC | | | |
| X1 | NOTE ADDED | 8-13-66 | G.D.L. | | | |
| X | EXPER. RELEASE | 8-11-66 | G.D.L. | QCB | | |
| SYM | DESCRIPTION | DATE | CH. NO. | DRAFTS | CHECKER | ENG. APP. |
| UNLESS OTHERWISE SPECIFIED DIMENSIONS ARE IN INCHES AND INCLUDE CHEMICALLY APPLIED OR PLATED FINISHES | | SCALE | | 1:1 | | |
| DECIMALS .X ± .05 .XX ± .01 .XXX ± .005 | TOLERANCES | FRACTIONS ± 1/64 ANGLES ± 0° 30' | CODE | A | | |

| REQ. ITEM | PART NO. | BUDETTI | DESCRIPTION | SYMBOL |
|-----------|--------------------|-------------------|--|----------|
| | 1/8 THK. | | THE TECHNICAL MATERIEL CORP. MAMARONECK. NEW YORK | |
| | STOCK SIZE | | ALUMINUM | |
| | | | WIPER, BAND SWITCH | |
| | | | | |
| | 5052-H32 | G.D.L. | QCB | QCB |
| | TYPE & TEMPER | HEAT TREAT. SPEC. | DRAWN | CHECKED |
| | S245 SILVER PLATE | S423 SILVER KOTE | QCB | QCB |
| | FINISH & SPEC. NO. | ELEC. DES. APP. | MECH. DES. APP. | |
| | | | | MS5037 Q |