

REVISIONS				DATE	APPROVED
EMN NO	DRAFT	CHKD	ZONE	LTR	DESCRIPTION
2197A	GDL			Δ	REDDAWN & REVISED WAS ON SIZE "A"
					3.14.82

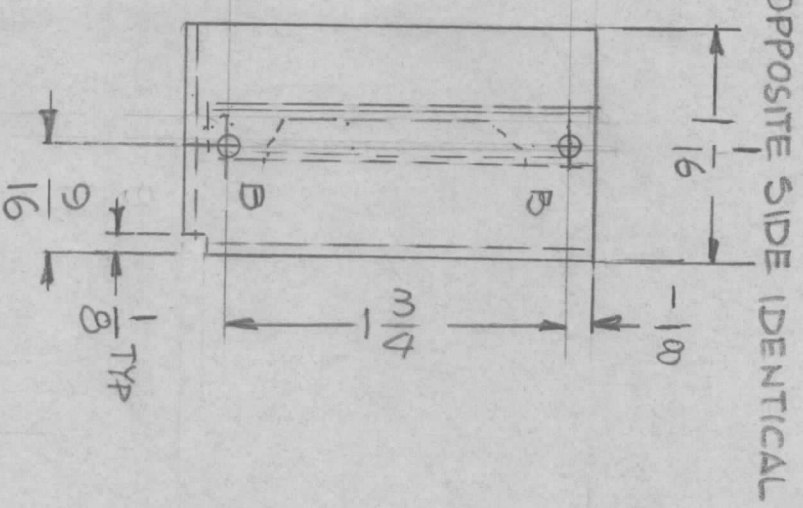
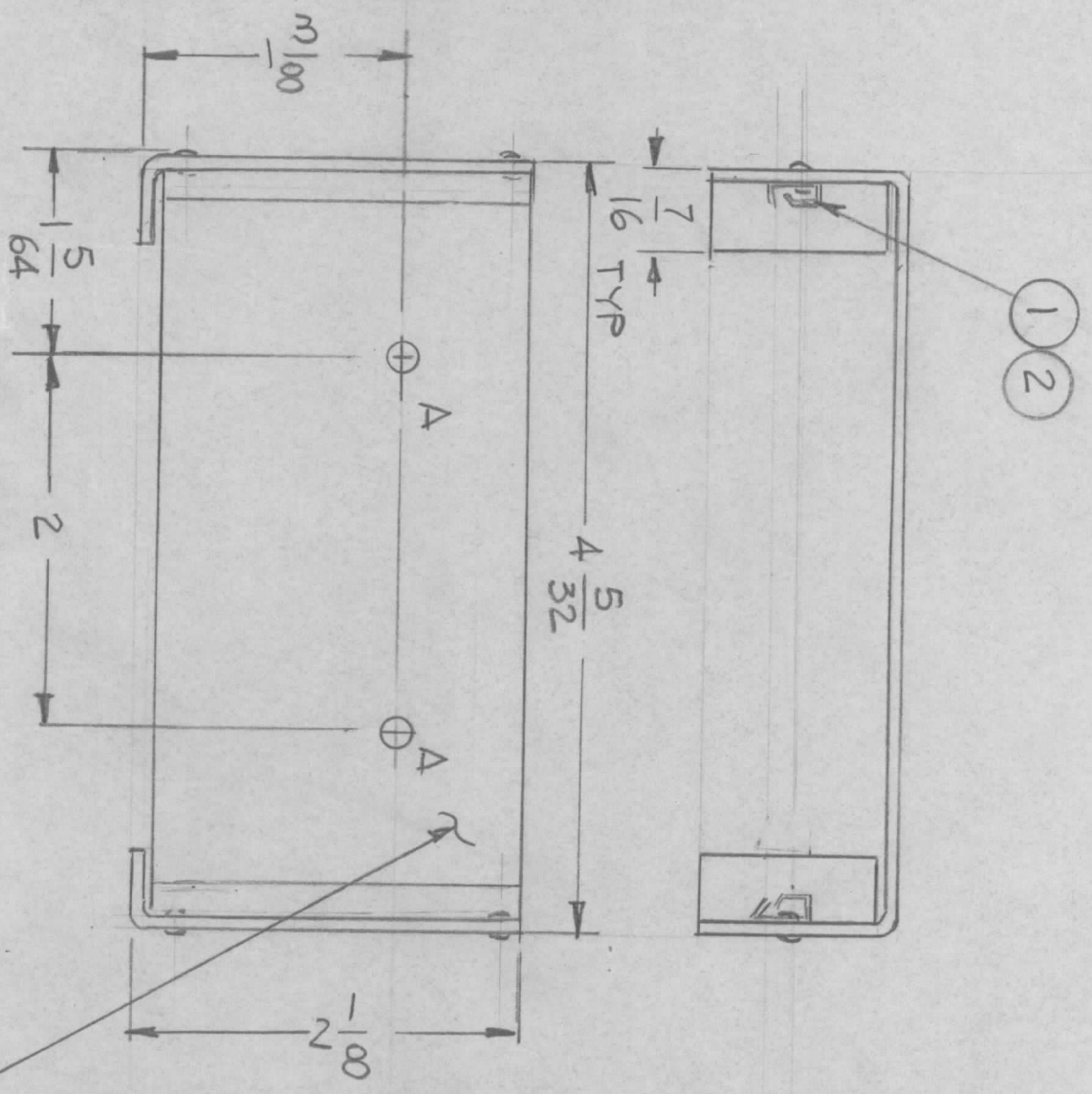

- HOLES -
 A - 11/64 DIA 2 REQ'D
 B - .067 DIA 4 REQ'D

MARK TMC P/NO 1/8 HIGH
 GOTHIC W/LATEST REV.
 LETTER

REQ'D ITEM	PART NUMBER	DESCRIPTION	SYM.
4	2 EY100-5	EYELET, FLAT FLANGE	
2	1 CU157-2	RETAINER PC BD	

LIST OF MATERIAL
THE TECHNICAL MATERIEL CORP.
 MAMARONECK, NEW YORK

BRKT, MOUNTING
 RISER CARD

- UNLESS OTHERWISE SPECIFIED:
1. USE MATERIAL THICKNESS FOR MAXIMUM RADIUS ON ALL BENDS.
 2. ALL ANGULAR BENDS 90 DEGREES.
 3. REMOVE ALL BURRS AND SHARP EDGES.
 4. MOUNT INSERTS AFTER FINISHING.

QTY / UNIT	CFD-2	ASSY NO.	A5521
MODEL USED ON		APPLICATION	
CODE			

NOTICE TO PERSONS RECEIVING THIS DRAWING
 THE TECHNICAL MATERIEL CORPORATION claims proprietary right in the material disclosed hereon. This drawing is issued in confidence for engineering information only and may not be reproduced or used to manufacture anything shown hereon without permission from THE TECHNICAL MATERIEL CORPORATION to the user. This drawing is loaned for mutual assistance and is subject to recall at any time.

DECIMALS	FRACTIONS	TOLS.	ANGLES
.X ± .05	1/64	.XX ± .01	90° .30'
.XXX ± .005			
MATERIAL	FINISH		
ALUM. 5052-H32	S404		
	YEL IRIDITE		

FINAL APPROVAL	DATE
MECH. DES.	DATE
ELECT. DES.	DATE
CHECKED	DATE
DRAWN	DATE

SIZE	CODE IDENT. NO.	DWG NO.	ISSUE
B	82679	MS 4931	A
SCALE	1 : 1		SHEET OF