

REQ. PER UNIT	USED ON			MS4885 \emptyset
	MODEL	ASS'Y. NO.	DATE	
1	CAB-20A		1-5-66	

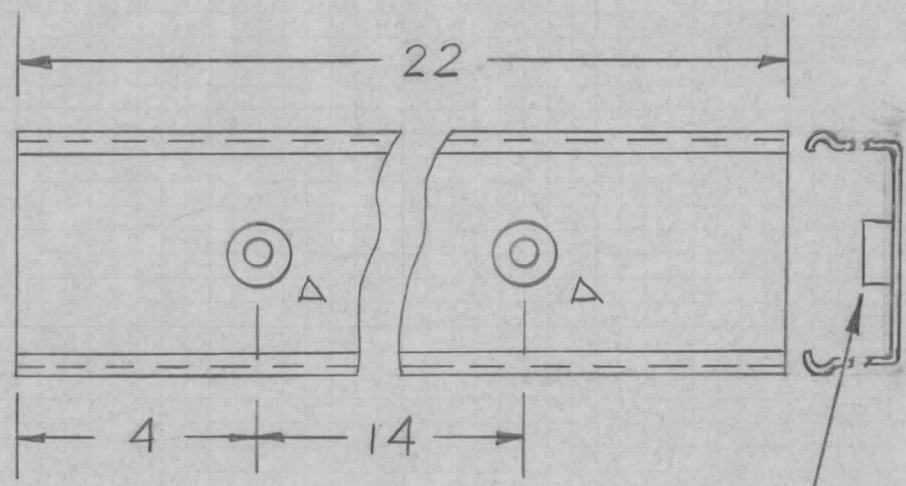

HOLE
 Δ -.191-.194 DIA. REQ. 2

① MOUNT IN ALL "A" HOLES

		2		1		NT129-632-4		NUT, SWAGE			
		REQ. ITEM		PART NO.		DESCRIPTION		PE10666		SYMBOL	
		TMC #		PO160		STOCK SIZE		THE TECHNICAL MATERIEL CORP.		MAMARONECK. NEW YORK	
		AC STRIP									
\emptyset ORIGINAL RELEASE FOR PRODUCTION		3-15-66		A		Jc					
SYM DESCRIPTION		DATE		CH. NO.		DRAFTS		CHECKER		ENG. APP.	
UNLESS OTHERWISE SPECIFIED DIMENSIONS ARE IN INCHES AND INCLUDE CHEMICALLY APPLIED OR PLATED FINISHES		SCALE									
DECIMALS .X \pm .05 .XX \pm .01 .XXX \pm .005		FRACTIONS \pm 1/64 ANGLES \pm 0° 30'		CODE A							
TOLERANCES								M.H.S 1-5-66		JCB	
								DRAWN		CHECKED	
								TYPE & TEMPER		HEAT TREAT. SPEC.	
								FINISH & SPEC. NO.		ELEC. DES. APP.	
								MECH. DES. APP.		3-15-66	
										MS4885 \emptyset	