

- HOLE -  
A - 11/64 DIA. 2 REQ.

REQ. PER UNIT	USED ON			MS4872	A
	MODEL	ASS'Y. NO.	DATE		
1	TOC-7	A5434	2-16-66		

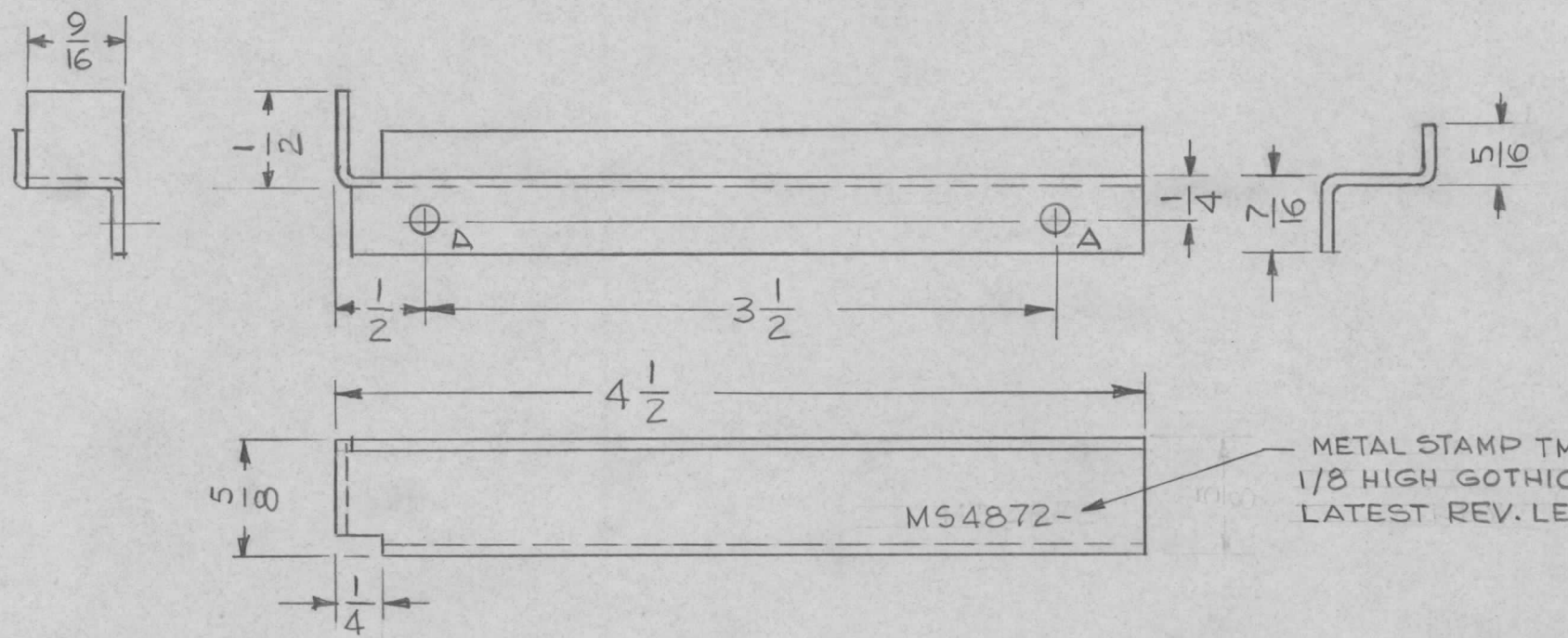

METAL STAMP TMC P/No. 1/8 HIGH GOTHIC, WITH LATEST REV. LETTER

~ FINISH NOTE ~  
1-5104 PASSIVATE  
2-5114 ZINC CHROMATE PRIMER  
3-5115 SMOOTH GRAY ENAMEL

UNLESS OTHERWISE SPECIFIED:

1. USE MATERIAL THICKNESS FOR MAXIMUM RADIUS ON ALL BENDS
2. ALL ANGULAR BENDS 90 DEGREES
3. REMOVE ALL BURRS AND SHARP EDGES

REQ.	ITEM	PART NO.	POSE	DESCRIPTION	SYMBOL	
		16 GA (.063)		THE TECHNICAL MATERIEL CORP. MAMARONECK, NEW YORK		
		STAINLESS STEEL			BRACKET, MTG. RIGHT SIDE	
A	DELE. FINISH NOTES 2 & 3	5/2/66	16191	HCA	<i>[Signature]</i>	
Ø	ORIGINAL RELEASE FOR PRODUCTION	3/28/66	-	HCA	<i>[Signature]</i>	
SYM	DESCRIPTION	DATE	CH. NO.	DRAFTS	CHECKER	ENG. APP.
UNLESS OTHERWISE SPECIFIED DIMENSIONS ARE IN INCHES AND INCLUDE CHEMICALLY APPLIED OR PLATED FINISHES		SCALE		1:1		
DECIMALS .X ± .05 .XX ± .01 .XXX ± .005	TOLERANCES	FRACTIONS ± 1/64 ANGLES ± 0° 30'	CODE	A		
SEE NOTES		FINISH & SPEC. NO.		ELEC. DES. APP.	MECH. DES. APP.	MS4872 A