

MOUNT 1/4-20 WELD NUT
IN "B" HOLES AS SHOWN
AFTER FINISHING

REQ. PER UNIT	USED ON			MS4802	A
	MODEL	ASS'Y. NO.	DATE		
1	GPT-40KEF	AP118	1/14/66		

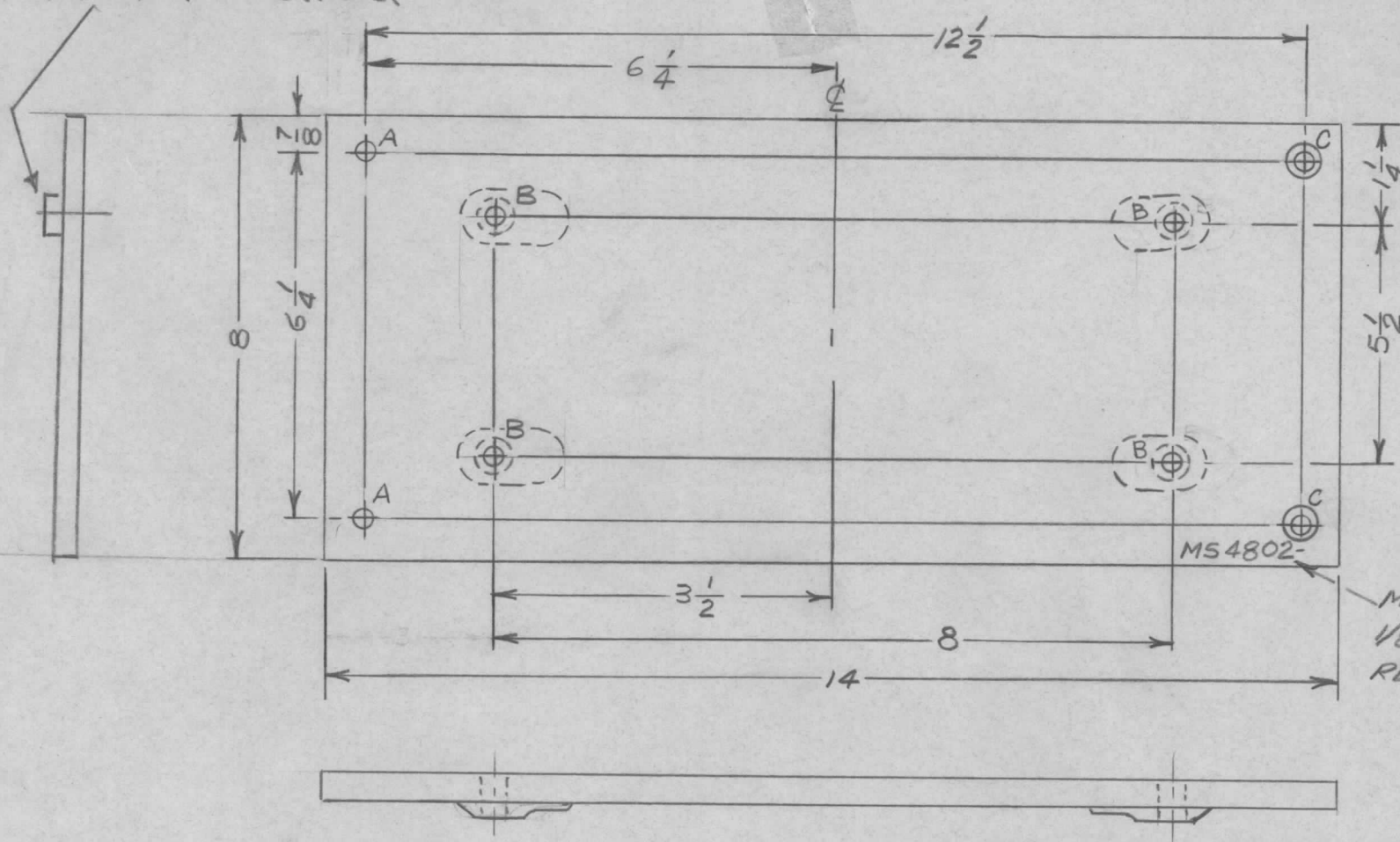

HOLES
A-5/16 DIA. (2 REQ.)
B-1/4-20 WELD NUT (4 REQ.)
C-DRILL .270 DIA.
C'SINK 82° TO .520 DIA. (2 REQ.)

METAL STAMP TMC P/N
1/8 HIGH GOTHIC W/LATEST
REVISION LETTER.

REQ.	ITEM	PART NO.	BUDETTI	DESCRIPTION	SYMBOL			
		3/16 THICK STOCK SIZE		THE TECHNICAL MATERIEL CORP. MAMARONECK, NEW YORK				
A	LOCATION OF WELD NUTS ADDED	10-3-66	16965					
Ø	ORIG. RELEASE FOR PROD.	1-26-66	Ø					
		HOT ROLLED STEEL PLATE		PLATE, MTG. XFMR				
SYM	DESCRIPTION	DATE	CH. NO.	DRAFTS	CHECKER	ENG. APP.		
UNLESS OTHERWISE SPECIFIED DIMENSIONS ARE IN INCHES AND INCLUDE CHEMICALLY APPLIED OR PLATED FINISHES		SCALE						
DECIMALS .X ± .05 .XX ± .01 .XXX ± .005	TOLERANCES	FRACTIONS ± 1/64 ANGLES ± 0° 30'	CODE					
				TYPE & TEMPER	HEAT TREAT. SPEC.	DRAWN	CHECKED	FINAL APPROVAL
				COPPER FLASH		DA		MS4802 A
				FINISH & SPEC. NO.		ELEC. DES. APP.	MECH. DES. APP.	