

REQ. PER UNIT	USED ON			MS4796 \emptyset
	MODEL	ASS'Y. NO.	DATE	
1	PSP 350B		10-27-65	

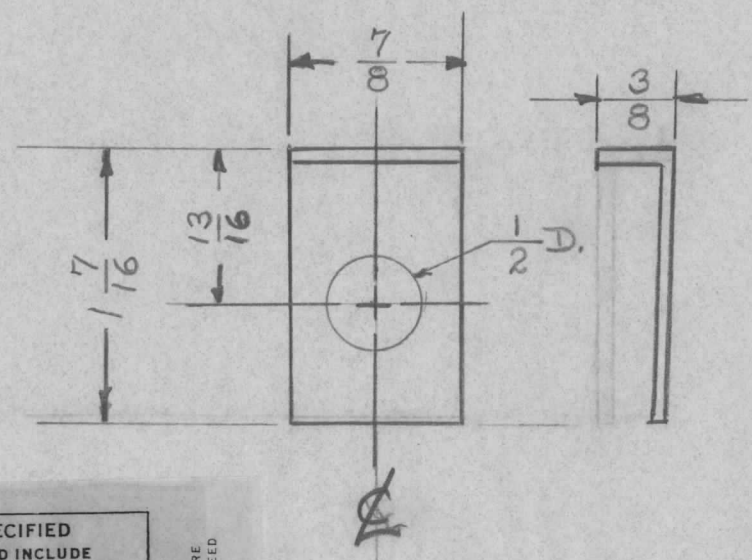

UNLESS OTHERWISE SPECIFIED
DIMENSIONS ARE IN INCHES AND INCLUDE
CHEMICALLY APPLIED OR PLATED FINISHES

DECIMALS	TOLERANCES	FRACTIONS
.X \pm .05		\pm 1/64
.XX \pm .01		ANGLES
.XXX \pm .005		\pm 0° 30'

CUT HERE
GUARANTEED
2-66

REQ. ITEM	PART NO.	DESCRIPTION	SYMBOL
	.064	THE TECHNICAL MATERIEL CORP. MAMARONECK, NEW YORK	\emptyset
	STOCK SIZE		
	ALUMINUM	BRACKET, COVER SUPPORT	
	MATERIAL		
ISSUE	CHANGED FROM	DATE	CH. NO. DRAFTS CHECKER ENG. APP.
	ORIGINAL RELEASE	10/27/65	File
TOLERANCES		SCALE:	
DEC. DIM. \pm	MAXIMUM ALLOWABLE TOLERANCES HAVE BEEN DETERMINED AND ANY DEVIATIONS WILL BE CAUSE FOR REJECTION.		
FRAC. DIM. \pm	REMOVE ALL BURRS AND SHARP EDGES		
ANGULAR DIM. \pm			
	5052-H32	FS 10/27/65	10/27/65
	TYPE & TEMPER	HEAT TREAT. SPEC.	DRAWN
	S404 YEL IRIDITE		CHECKED
	FINISH & SPEC. NO.	ELEC. DES. APP.	MECH. DES. APP.
			MS-4796 \emptyset