

HOLE	DESCRIPTION	QTY
A	.161-.164 DIA.	4
B	SEE DETAIL	8

REVISIONS						
SYM	DESCRIPTION	DATE	E.M.N. NO.	DRAFT	CHKD	APPD
Ø	ORIGINAL RELEASE FOR PRODUCTION	4-22-65		HCA		
A	2"B" DETAILS RELOCATED	6-22-65	14334	DVV	<i>Q/B</i>	<i>JEE</i>

MS4530

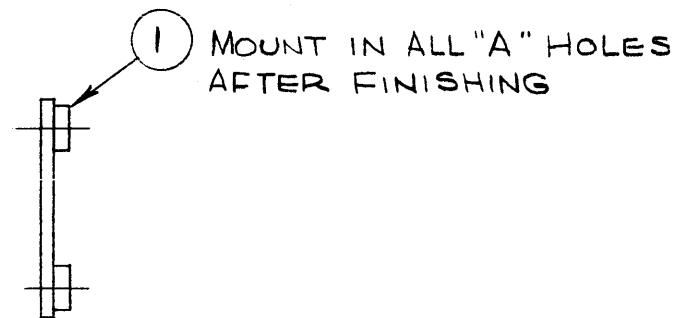
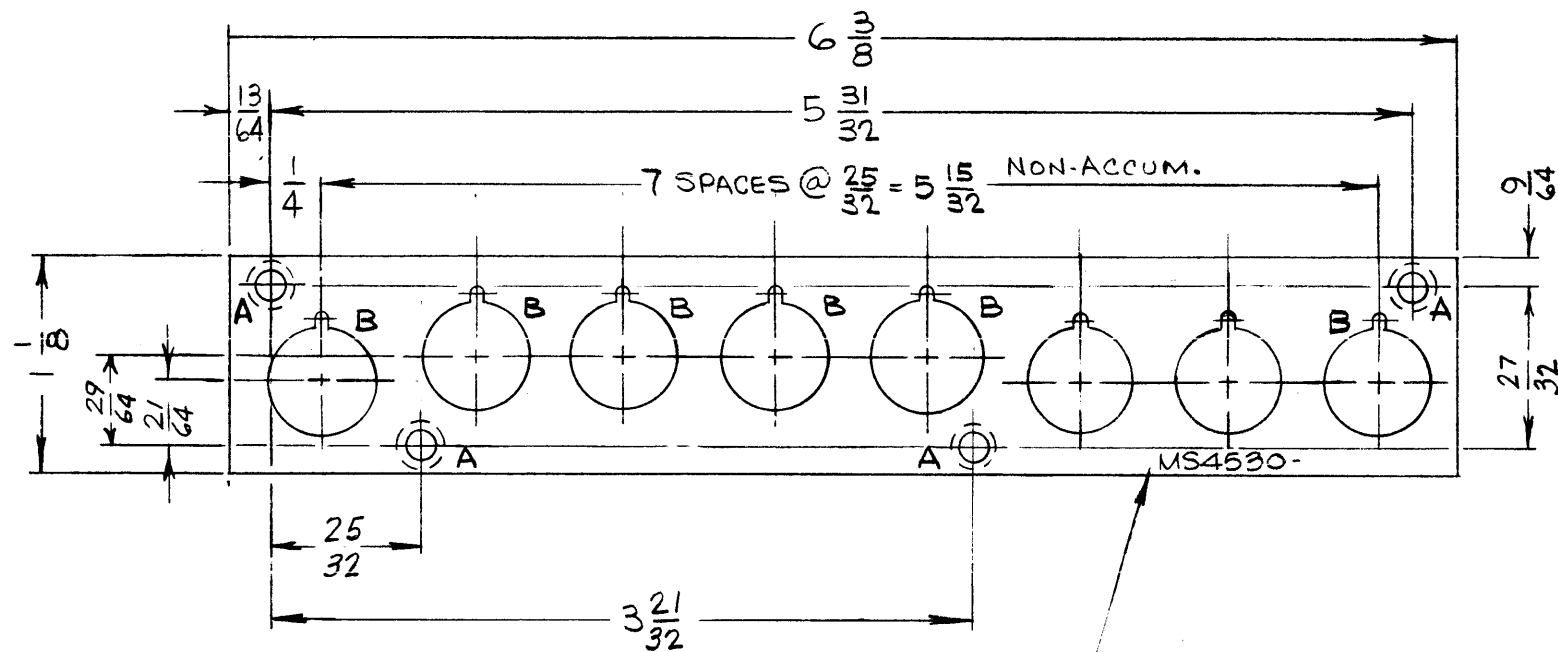

METAL STAMP TMC PART NO. 1/8 HIGH GOTHIC.
W/LATEST REVISION LETTER

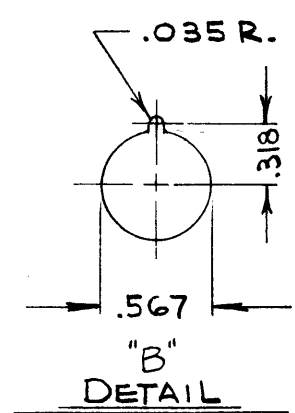

NOTES

1	LRCM-1	AX568
Q'TY./UNIT	MODEL USED ON	ASS'Y. NO.
SCALE 1:1	CODE	
THE CONTENTS OF THIS DRAWING ARE THE EXCLUSIVE PROPERTY OF THE TECHNICAL MATERIEL CORP. ITS UNAUTHORIZED USE OR REPRODUCTION IN WHOLE OR IN PART IS STRICTLY FORBIDDEN.		

4	1	NT129-440-4	NUT, PLN, SPLINE	
REQ'D.	ITEM	PART NUMBER	DESCRIPTION	SYMBOL
M. ZETENA LIST OF MATERIAL				
MATERIAL 080 ALUMINUM 5052 H32			THE TECHNICAL MATERIEL CORP. MAMARONECK, NEW YORK	
FINISH S404 YELLOW IRIDITE			TITLE PLATE, PUSHBUTTON SUPPORT XMTR	
UNLESS OTHERWISE SPECIFIED DIMENSIONS ARE IN INCHES AND INCLUDE CHEMICALLY APPLIED OR PLATED FINISHES				
DECIMALS .X ± .05 .XX ± .01 .XXX ± .005	TOLERANCES		FRACTIONS ± 1/64 ANGLES ± 0° 30'	
DRAWN H. AUSTIN	DATE 4-22-65	FINAL APPROVAL <i>JEE</i>	DATE 4/23/65	
CHECKED <i>Q/B</i>	DATE 4/22/65	MS4530		A
ELECT. DES.	DATE	SHEET		REV. LTR.
MECH. DES. <i>M.F.3</i>	DATE 4-23-65			