

HOLES:

A - 5/8 DIA
B - 3/8 DIA

REQ.

1
1

REQ. PER UNIT	USED ON		
	MODEL	ASS'Y. NO.	DATE
1	AP126		3-24-65

MS4459 Q

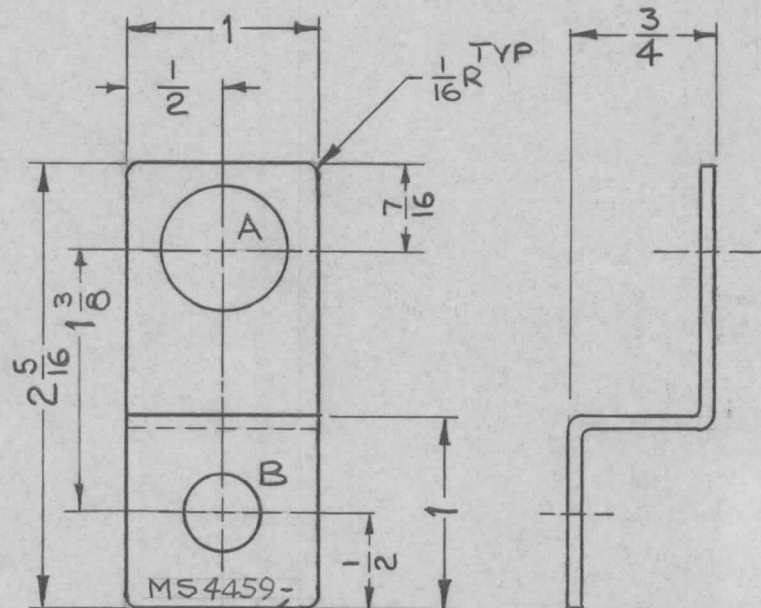

METAL STAMP
TMC P/N, 1/8 HIGH GOTHIC WITH
LATEST REVISION LETTER

UNLESS OTHERWISE SPECIFIED:

1. USE MATERIAL THICKNESS FOR MAXIMUM RADIUS ON ALL BENDS
2. ALL ANGULAR BENDS 90 DEGREES
3. REMOVE ALL BURRS AND SHARP EDGES

REQ.	ITEM	PART NO.	DESCRIPTION				SYMBOL
		.064 THK	THE TECHNICAL MATERIEL CORP.				
		STOCK SIZE	MAMARONECK, NEW YORK				
Q	ORIGINAL RELEASE FOR PRODUCTION	8.25.66	Q	RME			
X		3.24.65	X	ATB			
SYM	DESCRIPTION	DATE	CH. NO.	DRAFTS	CHECKER	ENG. APP.	
UNLESS OTHERWISE SPECIFIED DIMENSIONS ARE IN INCHES AND INCLUDE CHEMICALLY APPLIED OR PLATED FINISHES		SCALE 1:1					
DECIMALS .X ± .05 .XX ± .01 .XXX ± .005	TOLERANCES	FRACTIONS ± 1/64 ANGLES ± 0° 30'	CODE A				
5052 H32		3.24.65	WOB	HOC	OTB	MA	
S404 YELL. IRIDITE							
FINISH & SPEC. NO.		ELEC. DES. APP.	MECH. DES. APP.		MS4459	Q	