

| | | | | | |
|---------------|---------|------------|---------|--------|---|
| REQ. PER UNIT | USED ON | | | MS4456 | Ø |
| | MODEL | ASS'Y. NO. | DATE | | |
| 2 | RFTA-1 | | 3-10-65 | | |

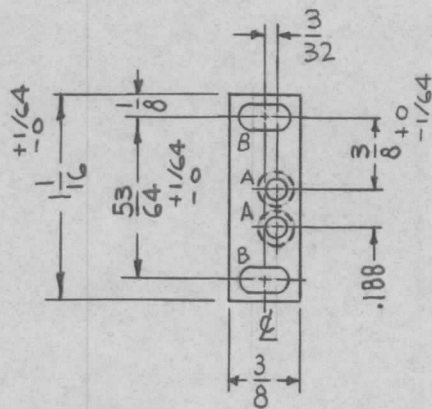

HOLES:

A ~ DRILL .090 DIA. C'SINK 82° X .177 DIA. (2REQ.)

B ~ 1/4 X 1/8 SLOTS (2REQ.)

| REQ. ITEM | PART NO. | F. BUDETTI | DESCRIPTION | SYMBOL | | | | | | | | |
|-------------------------------------------------------------------------------------------------------|-------------|------------------------------|------------------------------|-------------------|---------|-------------------|-----------------|-----|-----------------|-----|----------------|---|
| | .050 THICK | | THE TECHNICAL MATERIEL CORP. | | | | | | | | | |
| | STOCK SIZE | | MAMARONECK. NEW YORK | | | | | | | | | |
| Ø | ALUMINUM | | PLATE, MTG, SWITCH | | | | | | | | | |
| | MATERIAL | | | | | | | | | | | |
| SYM | DESCRIPTION | DATE | CH. NO. | DRAFTS | CHECKER | ENG. APP. | 5052-H32 | SRG | QC | OSB | MS4456 | Ø |
| UNLESS OTHERWISE SPECIFIED DIMENSIONS ARE IN INCHES AND INCLUDE CHEMICALLY APPLIED OR PLATED FINISHES | | | | | | | SCALE | 1:1 | DRAWN | | FINAL APPROVAL | |
| DECIMALS | TOLERANCES | FRACTIONS | CODE | TYPE & TEMPER | | HEAT TREAT. SPEC. | ELEC. DES. APP. | | MECH. DES. APP. | | | |
| .X ± .05 .XX ± .01 .XXX ± .005 | | ± 1/64 ANGLES ± 0° 30' | A | S404 YEL. IRIDITE | | | | | | | | |