

REQ. PER UNIT	USED ON			MS 4341 Ø
	MODEL	ASS'Y. NO.	DATE	
2	GPT-10K()7		2-5-65	

HOLES	DESCRIPTION	REQ.
A	3/16 X 3/8 SLOT	1
B	.191-.194 DIA.	2

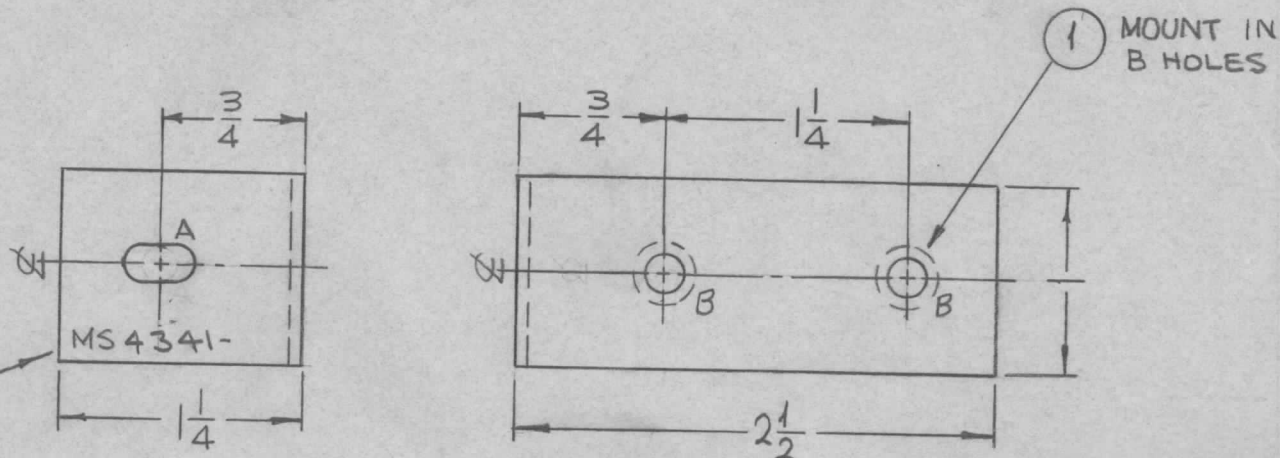

METAL STAMP TMC
PART NO., 1/8 HIGH
GOTHIC W/LATEST REV.
LETTER.

UNLESS OTHERWISE SPECIFIED:

1. USE MATERIAL THICKNESS FOR MAXIMUM RADIUS ON ALL BENDS
2. ALL ANGULAR BENDS 90 DEGREES
3. REMOVE ALL BURRS AND SHARP EDGES
4. MOUNT INSERTS AFTER FINISHING

SYM	DESCRIPTION	DATE	CH. NO.	DRAFTS	CHECKER	ENG. APP.	REQ. ITEM	PART NO.	DESCRIPTION	SYMBOL	
Ø	ORIGINAL RELEASE	8-20-65	Ø	GDL			2	1	NT129-632-4	NUT, PLAIN, SPLINE	B
X	EXP. RELEASE	2-5-65	X	SRG					1081 THICK	F. BUDETTI	
									STOCK SIZE	DESCRIPTION	
									ALUMINUM	THE TECHNICAL MATERIEL CORP. MAMARONECK, NEW YORK	
									MATERIAL	BRACKET, SHIELD MTG	
									5052-H32	SRG	
									TYPE & TEMPER	CHECKED	
									HEAT TREAT. SPEC.	FINAL APPROVAL	
									S404 YEL. IRIDITE		
									FINISH & SPEC. NO.	ELEC. DES. APP.	
										MECH. DES. APP.	
											MS 4341 Ø