

MAT'L - 1/8 THICK ALUMINUM
5052-H32

METAL STAMP TMC PART NO.
(MS4284) 1/8 HIGH GOTHIC
W/LATEST REV. LETTER
ON REAR.

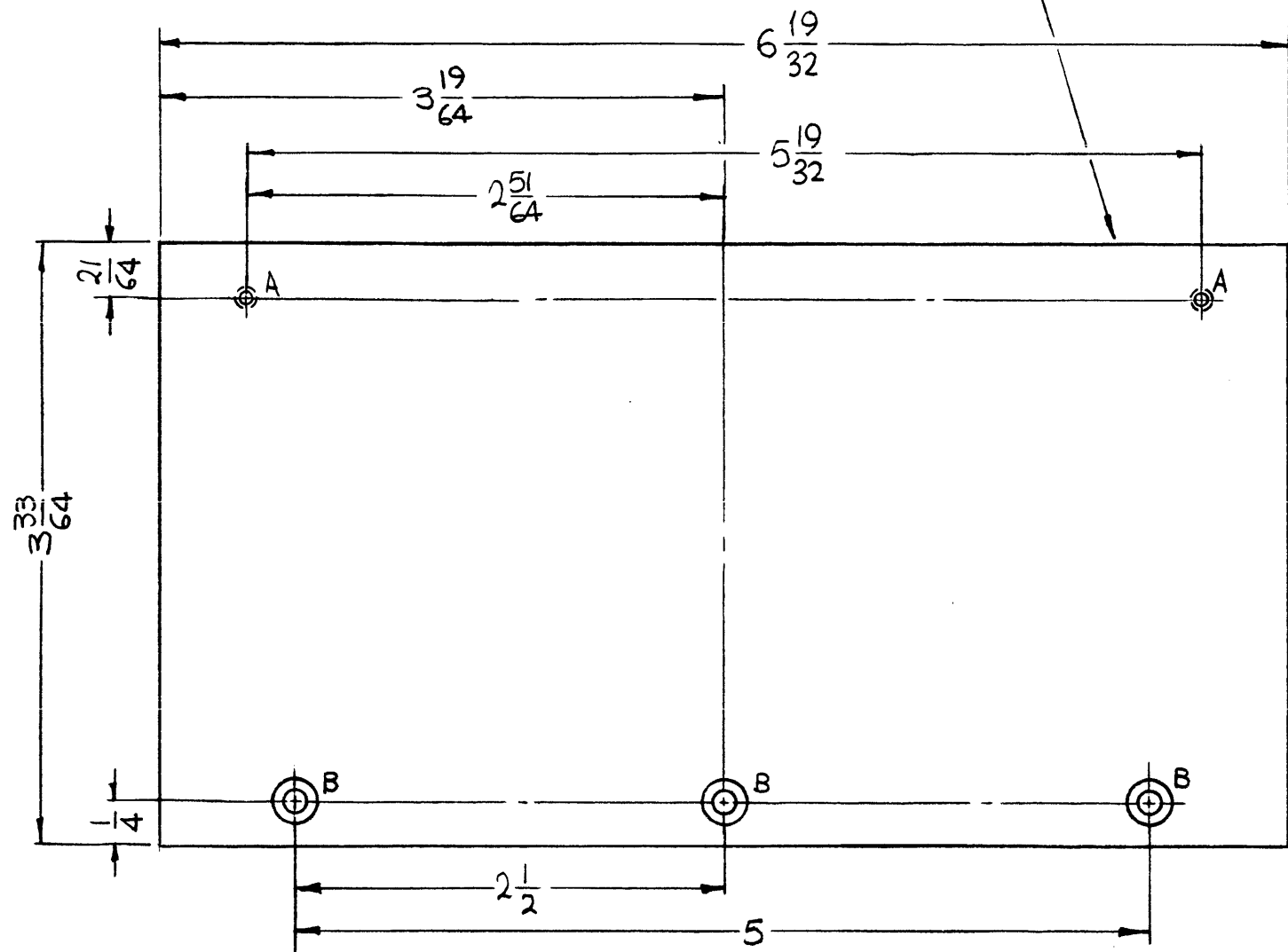

DOOR
FRONT VIEW

MACHINING:

1. MILL ALL EDGES.
2. HOLES MUST BE DRILLED, UNLESS OTHERWISE SPECIFIED.
3. LATERAL BOW OF DOOR MUST BE KEPT TO .031 TOLERANCE.
4. DOOR MUST BE FREE OF ALL MACHINING MARKS, GOUGES AND SCRATCHES. IF NECESSARY, SAND FRONT OF DOOR WITH NO. 120 GRIT SANDPAPER.

FINISH NOTES:

1. S404 - IRIDITE 14-2 AL-COAT.
2. S114 - ZINC CHROMATE PRIMER) FRONT AND
3. S115 - SMOOTH GRAY ENAMEL) REAR

NOTES

1	TSTE-10K	
Q'TY./UNIT	MODEL USED ON	ASS'Y. NO.
SCALE 1:1	CODE A	
THE CONTENTS OF THIS DRAWING ARE THE EXCLUSIVE PROPERTY OF THE TECHNICAL MATERIEL CORP. ITS UNAUTHORIZED USE OR REPRODUCTION IN WHOLE OR IN PART IS STRICTLY FORBIDDEN.		

MS4284

REVISIONS					
SYM	DESCRIPTION	DATE	E.M.N. NO.	DRAFT	CHKD APPD
X1	FINISH WAS ONLY FOR FRONT	4-22-65	X1	SRG	CA
Ø	ORIGINAL RELEASE FOR PRODUCTION	4-26-67	Ø	CV	

MAT'L ~ .040 THICK ALUMINUM
5052-H32

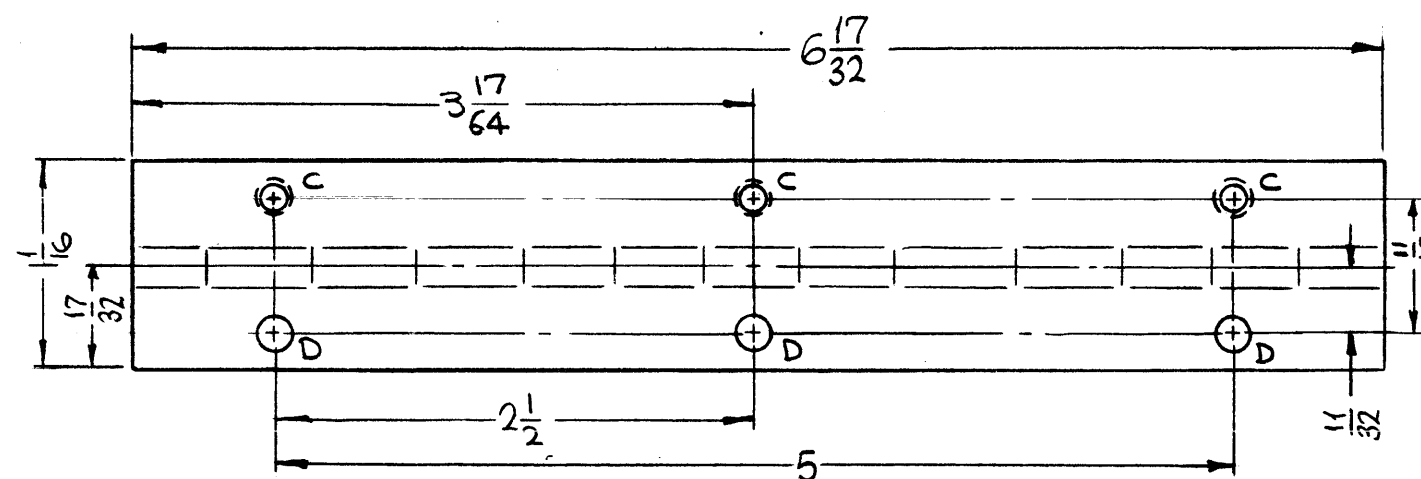

HINGE
FRONT VIEW

HOLES	DESCRIPTION	REQ.
A	DR. # TAP FOR G-32	2
B	DR. 1/8 DIA. C'SINK 82° X .250 D	3
C	DR. 1/8 DIA. C'SINK 82° X .171 DIA.	3
D	11/64 DIA.	3

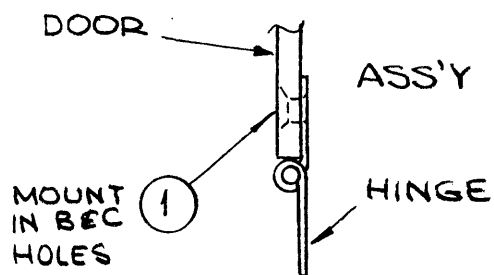

3	1	AN426AD4-3	RIVET	B, C
REQ'D.	ITEM	PART NUMBER	DESCRIPTION	SYMBOL
F. BUDETTI LIST OF MATERIAL				
MATERIAL SEE DWG			THE TECHNICAL MATERIEL CORP. MAMARONECK, NEW YORK	
FINISH SEE NOTES			TITLE DOOR, PANEL, FRONT	
UNLESS OTHERWISE SPECIFIED DIMENSIONS ARE IN INCHES AND INCLUDE CHEMICALLY APPLIED OR PLATED FINISHES			DRAWN SRG	DATE 4-15-65
			CHECKED	DATE
			ELECT. DES.	DATE
			MECH. DES.	DATE
			FINAL APPROVAL MS4284	
			DATE 4/25/67	
			SHEET	
			REV. LTR.	