

REQ. PER UNIT	USED ON			MS4144	Ø
	MODEL	ASS'Y. NO.	DATE		
1	RAK106	A-4021			

-HOLE-  
A-.191-.194 DIA. 3 REQ.

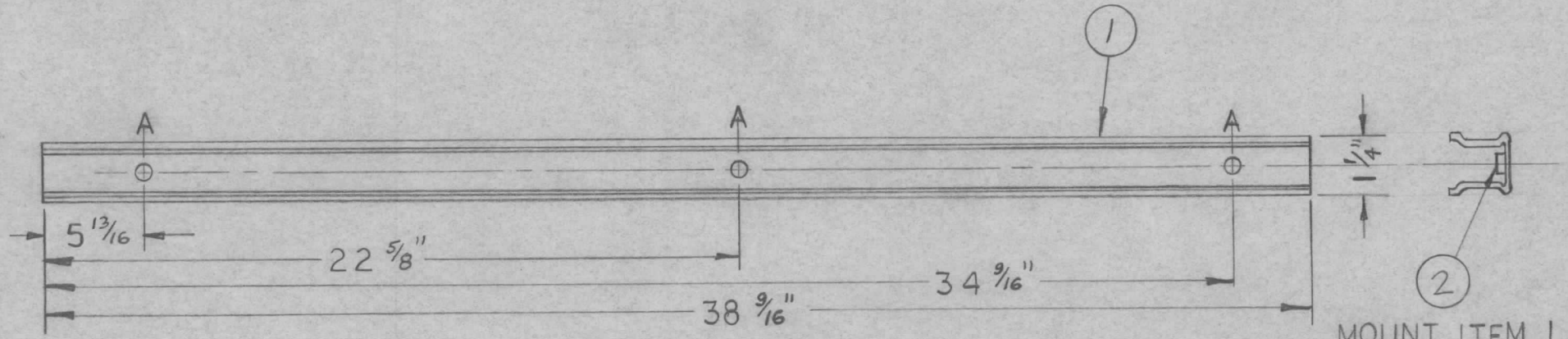

MOUNT ITEM 1 IN A HOLES AS SHOWN AFTER FINISHING.

MATERIAL: ...  
... MODIFIED AS SHOWN.

3	2	NT129-632-3	NUT, ROUND, SWAGE TYPE									
1	1	PO-160	CHANNEL (MODIFIED AS SHOWN)									
REQ. ITEM	PART NO.		DESCRIPTION	SYMBOL								
STOCK SIZE			THE TECHNICAL MATERIEL CORP. MAMARONECK, NEW YORK									
SEE NOTE												
MATERIAL			AC STRIP CHANNEL									
ISSUE	ITEM	CHANGED FROM	DATE	CH. NO.	DRAFTS	CHECKER	ENG. APP.	DRAWN	CHECKED	FINAL APPROVAL		
			12/8/65					I.J.	J.D. 12/8/65	M. H. King		
TOLERANCES			SCALE: NONE			TYPE & TEMPER		HEAT TREAT. SPEC.		FINISH & SPEC. NO.		
DEC. DIM. ±			MAXIMUM ALLOWABLE TOLERANCES HAVE BEEN DETERMINED AND ANY DEVIATIONS WILL BE CAUSE FOR REJECTION. REMOVE ALL BURRS AND SHARP EDGES							MS4144		
FRAC. DIM. ±												
ANGULAR DIM. ±												