

REQ. PER UNIT	USED ON			MS4126	Ø
	MODEL	ASS'Y. NO.	DATE		
2	COPA-2		11-5-64		

METAL STAMP TMC PART NO.
(MS4126-) 1/8 HIGH GOTHIC
W/LATEST REV. LETTER

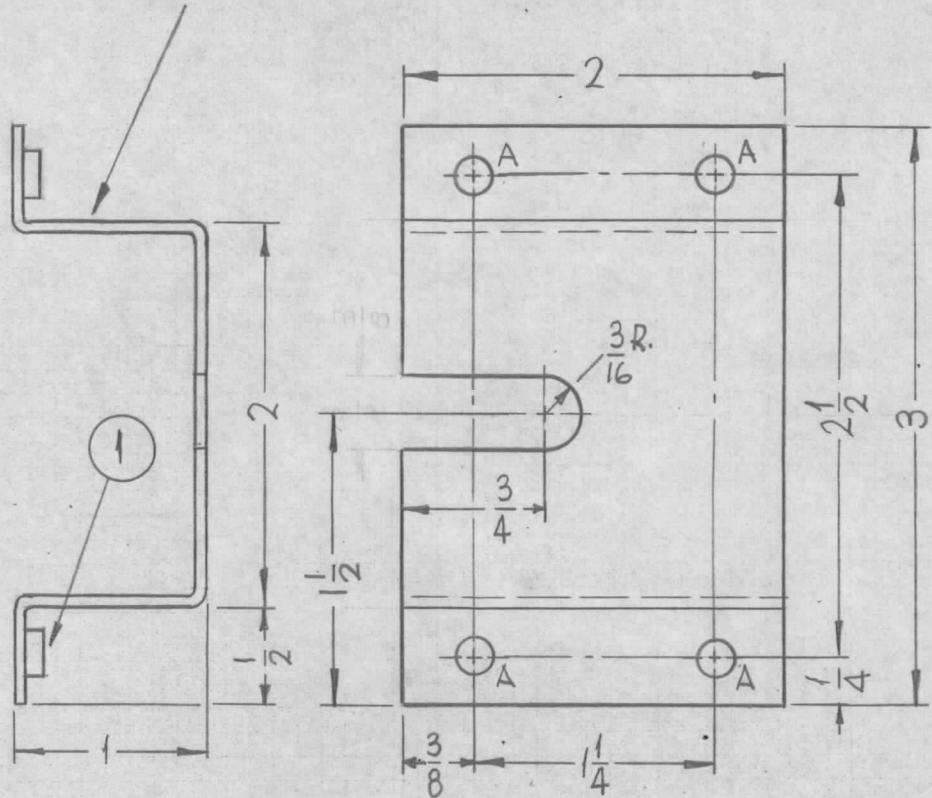

HOLE	DESCRIPTION	REQ
A	.191-194 DIA	4

- UNLESS OTHERWISE SPECIFIED:
1. USE MATERIAL THICKNESS FOR MAXIMUM RADIUS ON ALL BENDS
 2. ALL ANGULAR BENDS 90 DEGREES
 3. REMOVE ALL BURRS AND SHARP EDGES
 4. MOUNT INSERTS AFTER FINISHING

4	1	NT-129-632-4	NUT, PLAIN, SPLINE		A
REQ. ITEM	PART NO.		STURMER DESCRIPTION		SYMBOL
Ø	ORIGINAL RELEASE FOR PRODUCTION		.064 THICK STOCK SIZE		THE TECHNICAL MATERIEL CORP. MAMARONECK. NEW YORK
X	EXP. RELEASE		ALUMINUM		BRACKET, MTG, REEL ROD
SYM	DESCRIPTION		MATERIAL		
UNLESS OTHERWISE SPECIFIED DIMENSIONS ARE IN INCHES AND INCLUDE CHEMICALLY APPLIED OR PLATED FINISHES		SCALE	5052-H32	SRG	@11-16-64
		1:1	TYPE & TEMPER	HEAT TREAT. SPEC.	DRAWN
DECIMALS .X ± .05 .XX ± .01 .XXX ± .005		FRACTIONS ± 1/64 ANGLES ± 0° 30'	S404 YELLOW IRIDITE		CHECKED
TOLERANCES		CODE	FINISH & SPEC. NO.		FINAL APPROVAL
		A			MS4126 Ø
			ELEC. DES. APP.	MECH. DES. APP.	