

HOLES	DESCRIPTION	REQ.
A	11/64 DIA.	2
B	15/64 DIA.	4
C	3/8 DIA.	1
D	25/32 DIA.	2
E	.161-.164 DIA.	4

MS 3751

REVISIONS						
SYM	DESCRIPTION	DATE	E.M.N. NO.	DRAFT	CHKD	APFD
X	EXP. RELEASE	10-10-66	X		WV	
X1	4"A OBS. 2-3/8 LIP WAS 1/2	10-12-66	X1		WV	
Ø	ORIGINAL RELEASE FOR PRODUCTION					
A	DET. "D" DELETED, "E" HOLES Added	9/14/67	18507	JA	HQ	FB
B	1-1/4 X 3/16 (TYP) ADDED (NOTCH)	9-28-67	18528	H.G.		FB

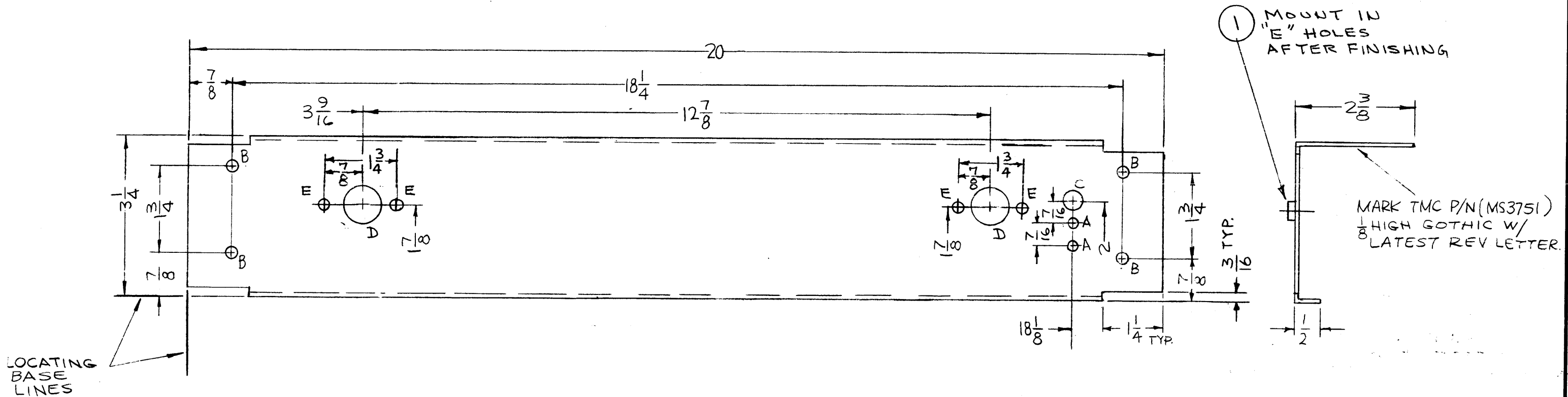

- UNLESS OTHERWISE SPECIFIED:
- USE MATERIAL THICKNESS FOR MAXIMUM RADIUS ON ALL BENDS
 - ALL ANGULAR BENDS 90 DEGREES
 - REMOVE ALL BURRS AND SHARP EDGES

NOTES

1	RAK-110-2	BMA 154
Q'TY./UNIT	MODEL USED ON	ASS'Y. NO.
SCALE 1:2	CODE A	

THE CONTENTS OF THIS DRAWING ARE THE EXCLUSIVE PROPERTY OF THE TECHNICAL MATERIEL CORP. ITS UNAUTHORIZED USE OR REPRODUCTION IN WHOLE OR IN PART IS STRICTLY FORBIDDEN.

4	1	NT129-440-3	NUT, PLAIN, SPLINE	
REQ'D.	ITEM	PART NUMBER	DESCRIPTION	SYMBOL
F. BUDETTI LIST OF MATERIAL				
MATERIAL 1/8 THICK ALUM. 5052-H32			THE TECHNICAL MATERIEL CORP. MAMARONECK, NEW YORK	
FINISH S404 YEL. IRIDITE			TITLE PANEL, FIXED FILTER	
UNLESS OTHERWISE SPECIFIED DIMENSIONS ARE IN INCHES AND INCLUDE CHEMICALLY APPLIED OR PLATED FINISHES			DRAWN 10-7-66	FINAL APPROVAL 3/1/67
			CHECKED 2-28-67	
			ELECT. DES.	MS3751
			MECH. DES.	B
			DATE 2/2/67	SHEET
				REV. LTR.