

SLOTS
A- 3/16 X 1/4 (3REQ.)

MS-3645

REVISIONS						
SYM	DESCRIPTION	DATE	E.M.N. NO.	DRAFT	CHKD	APFD
Ø	ORIGINAL RELEASE FOR PRODUCTION	5-6-64		SRG		

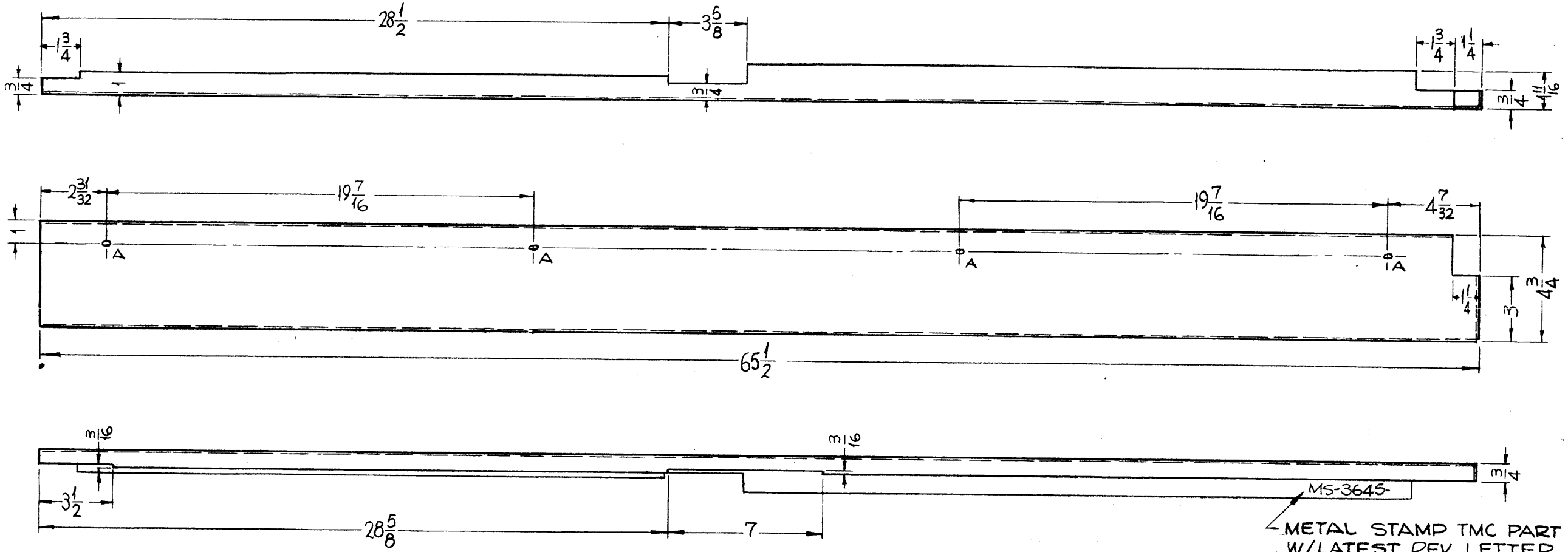

MS-3645
METAL STAMP TMC PART NO.
W/LATEST REV. LETTER.
1/8" HIGH GOTHIC.

UNLESS OTHERWISE SPECIFIED:

- USE MATERIAL THICKNESS FOR MAXIMUM RADIUS ON ALL BENDS
 - ALL ANGULAR BENDS 90°
 - REMOVE ALL BURRS AND SHARP EDGES
- FINISH:
S-371 DEGREASING
S-114 ZINC CHROMATE PRIMER
BLUE WRINKLE

NOTES

1	GPT-200K	
Q'TY./UNIT	MODEL USED ON	ASS'Y. NO.
SCALE 3/16 = 1"	CODE A	

THE CONTENTS OF THIS DRAWING ARE THE EXCLUSIVE PROPERTY OF THE TECHNICAL MATERIEL CORP. ITS UNAUTHORIZED USE OR REPRODUCTION IN WHOLE OR IN PART IS STRICTLY FORBIDDEN.

REQ'D.	ITEM	PART NUMBER	DESCRIPTION	SYMBOL
F. BUDETTI LIST OF MATERIAL				
MATERIAL 20 GA MILD STEEL			THE TECHNICAL MATERIEL CORP. MAMARONECK, NEW YORK	
FINISH SEE NOTE			TITLE TRIM, BOTTOM, FRONT	
UNLESS OTHERWISE SPECIFIED DIMENSIONS ARE IN INCHES AND INCLUDE CHEMICALLY APPLIED OR PLATED FINISHES			DRAWN SRG	DATE 12-30-63
			CHECKED JCB	DATE 5/6/64
			ELECT. DES.	DATE
			MECH. DES.	DATE
			FINAL APPROVAL <i>[Signature]</i> <i>[Signature]</i>	
			DATE 8/20/69	
			MS-3645	
			SHEET	
			REV. LTR.	