

MS-3578 A

REVISIONS

SYM	DESCRIPTION	DATE	E.M.N. NO.	DRAFT	CHKD	APFD
A	IT. 1 & 2 ADD., PICT. W/NOTE SHOWING IT. & 2 ADDED	7.22.64	11839	WB	@	TKA

MATERIAL NOTE:
PERFORATED AREA
.084 DIA. HOLES
ON 1/8 CENTERS
STAGGERED

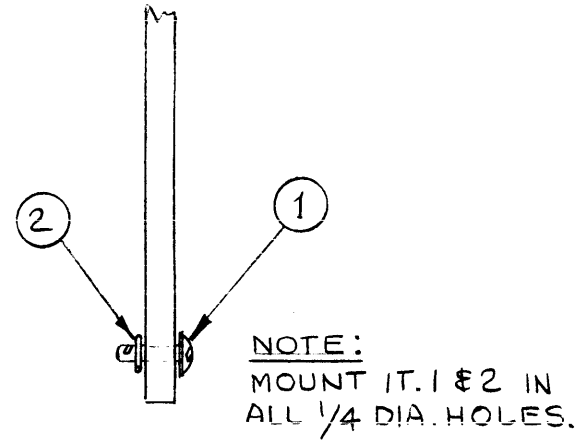
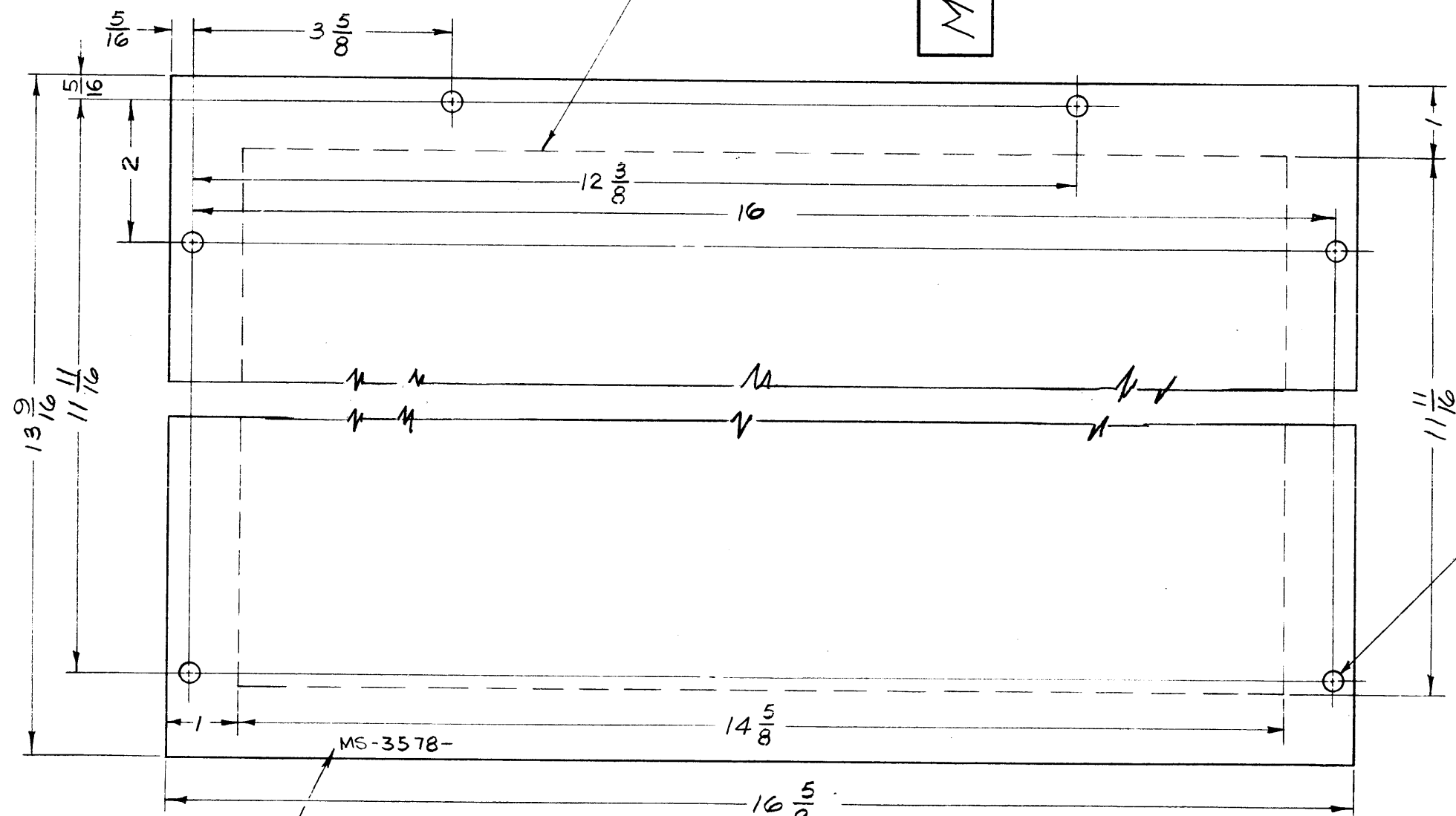

1/4 DIA.
6 HOLES

METAL STAMP TMC PART NO.
1/8 HIGH GOTHIC, WITH LATEST
REVISION LETTER.

REMOVE ALL BURRS AND SHARP EDGES.

REQ'D.	ITEM	PART NUMBER	DESCRIPTION	SYMBOL
6	2	FS 109-3	RING, RETAINING	
6	1	FS 110-1	STUD, TURN LOCK	

AALTONEN LIST OF MATERIAL

MATERIAL .051 ALUMINUM 5052-H32 PERFORATED (SEE NOTE)

FINISH 6404 YEL IRIDITE

THE TECHNICAL MATERIEL CORP.
MAMARONECK, NEW YORK

COVER, TOP & BOTTOM

2	MNF-1	
Q'TY./UNIT	MODEL USED ON	ASS'Y. NO.
SCALE 1:2	CODE A	

UNLESS OTHERWISE SPECIFIED DIMENSIONS ARE IN INCHES AND INCLUDE CHEMICALLY APPLIED OR PLATED FINISHES		DRAWN T. RAMIREZ	DATE 10/14/63	FINAL APPROVAL	DATE
DECIMALS .X ± .05 .XX ± .01 .XXX ± .005	TOLERANCES	CHECKED A. Tursi	DATE 1-10-64	MS-3578	A
FRACTIONS ± 1/64 ANGLES ± 0° 30'		ELECT. DES. TKA	DATE 1/21/64		
		MECH. DES. M. Selon	DATE 1-10-64		

NOTES

THE CONTENTS OF THIS DRAWING ARE THE EXCLUSIVE PROPERTY OF THE TECHNICAL MATERIEL CORP. ITS UNAUTHORIZED USE OR REPRODUCTION IN WHOLE OR IN PART IS STRICTLY FORBIDDEN.